

Polydoros RFX

High-voltage generator with Mini Console

Model/ID: 7021-8-9571

7021-8-9671

7021-8-9871

Manufactured by Siemens Healthcare GmbH

Material number: 11011021; 11011590

Instructions for use

Ident. Nr. 5021-0-1002

**NOTE**

The legal manufacturer of this product is

Siemens Healthcare GmbH

Henkestr. 127 | 91052 Erlangen

Germany

**NOTE**

All sheets of this document contain proprietary and confidential information of PROTEC X-ray Systems GmbH and is intended for exclusive use by current PROTEC X-ray Systems GmbH customers. Copying, disclosure to other or other use is prohibited without the express written authorization of PROTEC's law department. Report any violations of this requirement to PROTEC X-ray Systems GmbH.

© 2025 PROTEC X-ray Systems GmbH, Oberstenfeld

These accompanying documents were created and distributed by the documentation department.
Comments and questions about the documentation, please contact:

PROTEC X-ray Systems GmbH

In den Dorfwiesen 14 | 71720 Oberstenfeld

Germany

Phone: (+ 49) 7062 – 92 55 0

Fax: (+ 49) 7062 – 92 55 60

E-mail: protec@protec-med.com

Internet: www.protec-med.com

Table of contents

	Page
Table of contents.....	3
Document Effectivity.....	6
Introduction	8
1.1 General Information.....	8
1.1.1 Product Information.....	8
1.1.1.1 High-voltage Generator Models.....	8
1.1.1.2 Slide-in Module Service Parts	9
1.1.1.3 Accessories.....	9
1.1.1.4 Intended use.....	9
1.1.1.5 Improper Use.....	9
1.1.1.6 Indications	9
1.1.1.7 Contra indications	10
1.1.1.8 Intended patient population.....	10
1.1.1.9 Intended user	10
1.1.2 Document Information.....	11
1.1.2.1 Purpose of this Document	11
1.1.2.2 Text Layout.....	11
1.1.2.3 Illustrations.....	12
1.1.2.4 Value Statement	13
1.1.3 Acronyms and Abbreviations	13
1.1.4 Laws, Standards, and Regulations.....	14
1.1.4.1 High-voltage generator	14
1.1.4.2 Mini Console	15
1.2 Safety Information.....	16
1.2.1 Installation, Repair, or Modifications.....	16
1.2.2 Staff Qualification	17
1.2.2.1 Operating Staff.....	17
1.2.2.2 Installation, Maintenance and Repair Staff.....	17
1.2.3 Safety Instructions.....	17
1.2.3.1 Unpacking Hazards.....	17
1.2.3.2 Installation Hazards.....	17
1.2.3.3 Operating Hazards.....	18
1.2.4 Cleaning and Disinfection and Sterilization.....	21
1.2.4.1 High-voltage generator	21
1.2.4.2 Mini Console	21

1.2.5	Electromagnetic Compatibility.....	22
1.2.5.1	Electromagnetic Emissions.....	22
1.2.5.2	Electromagnetic Immunity.....	23
1.2.5.3	RF Immunity.....	25
1.2.6	Interfaces.....	27
1.2.7	Maintenance.....	27
1.2.8	Checks.....	27
1.2.9	Labels and Pictograms on the Product and Package.....	29
1.2.9.1	High-voltage generator.....	29
1.2.9.2	Mini Console.....	33
1.2.9.3	Description of the Identification Label.....	34
1.2.9.3.1	High-voltage generator.....	34
1.2.9.3.2	Mini Console.....	35
1.2.9.4	Description of the Logistic Material Number Label.....	35
1.2.9.5	Description of the Product Packing Label for Logistic Numbers.....	36
1.2.9.6	Description of the Product Packing Label for Shippable Configuration Elements.....	37
1.2.9.6.1	High-voltage generator.....	37
1.2.9.6.2	Mini Console.....	38
1.2.9.7	Label Positions.....	39
1.2.9.7.1	Location of the Labels on the Polydoros RFX.....	39
1.2.9.7.2	Location of the Labels on the High-voltage Tank.....	41
1.2.9.7.3	Location of the Labels on the AMC Box.....	42
1.2.9.7.4	Mini Console.....	43
1.2.10	Disposal.....	44
2	Technical Data.....	45
2.1	Electrical Data.....	45
2.1.1	Mains Connection.....	45
2.1.2	Internal Line Resistance.....	45
2.1.3	Fuses Overview.....	45
2.1.4	Performance Data.....	46
2.1.4.1	High-voltage generator.....	46
2.1.4.2	Mini Console.....	48
2.2	Mechanical Data.....	49
2.2.1	Hardware Configuration.....	49
2.2.2	Dimensions and Weight.....	50
2.2.3	Paint color.....	50
2.2.4	Control and Display Elements.....	51

2.2.5	Interfaces of the Mini Console.....	52
2.3	Dimensional Drawings	53
2.3.1	Mini Console Dimensions	53
2.3.2	Mounting Hole Dimensions	54
2.3.3	Vertical Design	55
2.3.4	Horizontal Design.....	56
2.3.5	Room Planning	57
2.4	Environmental Conditions	58
2.4.1	Transport and Storage Conditions	58
2.4.1.1	High-voltage generator	58
2.4.1.2	Mini Console	58
2.4.2	Operating Conditions.....	58
2.4.2.1	High-voltage generator	58
2.4.2.2	Mini Console	58
2.5	Classification	59
2.5.1	High-voltage generator.....	59
2.5.2	Mini Console.....	59
3	Console Operation	60
3.1	Switching On/Off the Generator.....	60
3.2	Exposure Release	61
4	Software Operation.....	62
4.1	Software X-ray Generator Control.....	62
4.2	Parameters of the Software X-ray Generator Control.....	62
5	Error messages.....	64

**NOTE**

The information contained in this document conforms to the configuration of the equipment as of the date of manufacture. Revisions to the equipment subsequent to the date of manufacture will be addressed in service updates distributed to the PROTEC Technical Service Organization.

Document Effectivity

Revision No.	Date	List of effective pages	Comments
1.0	2020-11-24	all	Original issue
2.0	2021-02-17	1	Added "Manufactured by Siemens Healthcare GmbH" incl. Model/ID
		2	Added note for legal manufacturer
3.0	2021-09-15	7	Chapter 1.1.1.1 "High-Voltage Generator Models" table 2 updated
		8	Chapter 1.1.1.3 "Slide-in Module Service Parts" table updated
			Chapter 1.1.1.4 "Accessories and Auxiliary Devices" removed (Cooling fan package)
		11	Symbol: Change "Electrical shock" into "Warning, electricity"
		12	Chapter 1.1.2.4 "Value Statement": 2 nd and 3 rd paragraph removed
		17	Chapter 1.2.3.2 "Installation Hazards": "Improper lifting" box changed
		18	Chapter 1.2.3.3 "Operating Hazards": "Accessible voltages" box changed
		19	Chapter 1.2.3.3 "Operating Hazards": "Wrong power supply cords" box changed
		26	Chapter 1.2.8 "Checks": Paragraph "Checks after switching on the generator": Remark on the power LED safety feature (double design -> 2 LEDs)
		28, 30	Chapter 1.2.9.2.1 "High-voltage generator": Cooling fan labels removed
		42	Chapter 1.2.9.7.3 "Location of the Labels on the Cooling Fan" removed
		42	Chapter 1.2.9.7.4 "Mini Console": additional information added
		47	Chapter 2.1.4.2 "Mini Console": Remark on the power LED safety feature (double design -> 2 LEDs)
		49	Chapter 2.2.1 "Hardware Configuration" Cooling fan package removed. Instead general description of external cooling fan included.
50	Chapter 2.2.2 "Dimensions and Weight" Cooling fan package removed. Instead general description of external cooling fan included.		
55	Chapter 2.3.3 "Vertical Design" drawings updated.		
56	Chapter 2.3.4 "Horizontal Design" drawings updated.		
57	Chapter 2.3.5 "Room planning": External cooling fan included to room planning (air flow rate).		

4.0	2022-01-20	8	Chapter 1.1.1.1 "High-voltage Generator Models": table 1: reference number "1" added
		13	Chapter 1.1.3 "Acronyms and Abbreviations": "OEM" removed
		14	Chapter 1.1.4.1 "High-voltage generator": table: typing errors corrected
		15	Chapter 1.1.4.2 "Mini Console": typing errors corrected
		17	Chapter 1.2.2.1 "Operating Staff": "personnel" replaced with "Staff"
		17	Chapter 1.2.3 "Safety Instructions": first sentence updated
		17	Chapter 1.2.3.1 "Unpacking Hazards": "Improper unpacking..." changed from Notice to Warning
		32	Chapter 1.2.9.1 "High-voltage generator": typing errors corrected
		43	Chapter 1.2.9.7.4 "Mini Console": drawing updated, important information added.
		46	Chapter 2.1.4.1 "High-voltage generator": table additional hint added, values for 30 kW and 40 kW generator removed, material number for AMC module added
		56	Chapter 2.3.4 "Horizontal Design": labelling corrected
		59	Chapter 2.5.2 "Mini Console": "Further classification statements are dependent on the overall context of the system periphery." added.
5.0	2023-05-08	Chap. 3.2	Note X-ray indication added
6.0	2023-09-11	14	Chapter 1.1.4.1: New formulation for IEC 63000
		31	Chapter 1.2.9.1: One UL label removed
		Chap.1.1.1.3	Changed in Accessories, RFX cable new
		Chap.1.2.9	Shipping label Cable Set new
7.0	2023-10-20	Chap. 5 all	Added error 0x19F (415) First edition „PROTEC X-ray Systems GmbH“

Introduction

1.1 General Information

1.1.1 Product Information

The Polydoros high-voltage generators are designed for use in a wide range of radiography systems. The modular design of the Polydoros family allows for adaption to the requirements of all medical X-ray applications.

The Polydoros RFX supports the following operating modes:

- Radiographic exposures on film, CR screens, and DR panels

The Mini Console provides a control panel for switching on/off the generator and releasing exposure including a radiation indicator. The radiographic parameters are to be set by the system via the digital interface.

The intended medical and patient application must be determined and described by the system manufacturer.

1.1.1.1 High-voltage Generator Models

This document applies to the following high-voltage generator models:

Model	Power rating	PROTEC article number ¹
Polydoros RFX Low Power	55 kW	7021-8-9571
Polydoros RFX Low Power	65 kW	7021-8-9671
Polydoros RFX High Power	80 kW	7021-8-9871

1. The logistic material number specifies the high-voltage generator model (Low/High Power)

The Polydoros RFX comprises the following slide-in modules, depending on the high-voltage generator model:

Module	High-voltage generator model	
	Polydoros RFX Low Power	Polydoros RFX High Power
MRC_1	✓	✓
RCE_1		✓
RCE_2	✓	
INV_1	✓	✓ (2x)
RFM_1	✓	✓
GCB_1	✓	✓

1.1.1.2 Slide-in Module Service Parts

Module	Description	Service part number
MRC_1	Mains rectifier and capacitor module	11011621
RCE_1	Resonant circuit extension module High Power configuration	111011611
RCE_2	Resonant circuit extension module Low Power configuration	11011612
INV_1	Inverter module	11011620
RFM_1	RAC filament and misc. module	11011622
GCB_1	Generator control board module	11011619

1.1.1.3 Accessories

The following parts are included in the scope of delivery.

Model	Description
Mini Console Package	Control panel for switching on/off the generator and releasing X-ray. An appropriate cable for connecting the generator is enclosed.
RFX Cable Set	Consisting of: High-voltage cable Protective earth cable Temperature/pressure switch cable stator cable

1.1.1.4 Intended use

These generators are standard, high-voltage generating devices which are intended to be integrated in diagnostic X-ray systems. An HV-generator is used to establish high voltage, the filament heating and (where applicable) the drive of the stator needed by the X-ray tube assembly for generating the X-ray beam.

Stationary HV-generators are integral components of diagnostic X-ray systems. They are used to regulate incoming voltage and current to provide an X-ray tube assembly with the power needed to produce an X-ray beam of the desired voltage (kV) and current (mA).

Especially these generators are intended to be used for radiography/fluoroscopy applications.

1.1.1.5 Improper Use

The manufacturer will not be held responsible for the safety features, reliability and performance of the product if

- the component is used in a manner other than specified in this document,
- personnel not authorized by the manufacturer performs installation, upgrades, modifications, or repairs,
- components affecting product safety are not replaced with original spare parts from PROTEC,
- electrical wiring in the operating room does not meet the specifications of local regulations.

1.1.1.6 Indications

Indication for use of the HV-generator is every clinical indication which requires a radiographic image or a fluoroscopic examination using a diagnostic X-ray system. The specific indications, parts of the body and the duration of the exposure for which the HV-generator can be used (once or repeated) are defined by the diagnostic X-ray system in which the HV-generator is integrated.

1.1.1.7 Contra indications

For HV-generators no other contra-indications besides the ones for general radiologic procedures are currently known. Specific contra-indications might need to be defined by the system integrator of the diagnostic X-ray system in which the HV-generator is integrated.

1.1.1.8 Intended patient population

The HV-generator may be used for each patient who is admitted for an X-ray examination, from newborn to geriatric. The patient population might need to be restricted on system level as result of the integration of the HV-generator into a diagnostic X-ray system by the system integrator.

1.1.1.9 Intended user

HV-generators are intended to be integrated into diagnostic X-ray systems by a system integrator, for whom it is required to have specific technical and clinical knowledge and skills, including but not limited to radiation protection, electrical and mechanical safety and clinical procedures for which the finalized system is released. Integrated into the diagnostic X-ray system, generators are intended to be operated by adequately trained clinical users.

1.1.2 Document Information

1.1.2.1 Purpose of this Document

This document (Instructions for Use) contains the required specifications of the high-voltage generator and the Mini Console required from standards and laws.

The information for installing, starting up, adjusting, operating, servicing, and maintaining the Polydoros RFX is given in the following accompanying document(s):

- Installation and Startup

1.1.2.2 Text Layout

Note:



NOTE

Example of a Note

A note emphasizes important information without there being any direct danger and helps you to operate the product properly and to avoid errors. It also provides additional useful explanations about a subject.

How safety information is structured:

NOTICE

Cause/Source of danger.

Possible consequences

⇒ Precautions or remedies

Classification:

Warning Indicates a hazard that if disregarded can cause death or serious injury.

Caution Indicates a hazard that if disregarded can cause minor or moderate injury.

Notice Indicates a situation that if disregarded can cause damage to the product or something else in your environment.

Symbols / Pictograms:

Symbols / Pictograms and their meanings as they may apply to your product (IEC standard):



General Warning



X-ray radiation: Warning of ionizing radiation.



Torque: Note about a threaded connector with a torque value.



Warning, electricity: Dangerous electrical voltage > 25 V AC or > 60 V DC.



Radio frequency: Warning of non-ionizing radiation.



Hot surfaces: Warning of hot surfaces.



Type B applied part



Power ON button



Power OFF button



Radiation LED



Exposure button

1.1.2.3 Illustrations

All illustrations of the equipment in this document are examples only.

Differences in detail may occur in your product due to the installed options, configurations, and constant development of the product.

Reproduction of images can cause loss of detail.

Pictures in this document do not therefore provide any indication of the image quality.

1.1.2.4 Value Statement

All technical data are typical values unless specific tolerances are stated.

1.1.3 Acronyms and Abbreviations

AEC	Automatic Exposure Control
AMC	AEC Multi Converter
CE	Communauté Européenne
CFR	Code of Federal Regulations
EEC	European Economic Community
EMC	Electromagnetic Compatibility
ESD	Electrostatic Discharge
EU	European Union
FTT	Fault Tolerance Time
GCB	Generator Control Board
HV	High Voltage
HVT	High-Voltage Tank
IEC	International Electrotechnical Commission
INV	Inverter
LED	Light Emitting Diode
MFOT	Multiple Fault Occurrence Time
MFF	Mains Fuses and Filter
MRC	Mains Rectifier and Capacitor
RAC	Rotating Anode Control
RCE	Resonant Circuit Extension
RF	Radio Frequency
RFM	RAC, Filament, and Miscellaneous
RöV	X-ray Ordinance (Röntgenverordnung)
RoHS	Restriction of certain Hazardous Substances
VDE	Association for Electrical, Electronic & Information Technologies

1.1.4 Laws, Standards, and Regulations

1.1.4.1 High-voltage generator

The high-voltage generator has been manufactured and developed in agreement with the applicable requirements according to the following laws, directives and design regulations:

- "This component" does not contain any substances that exceed the limitations defined in directive 2011/65/EU, Annex II on the restriction of the use of certain hazardous substances in electrical and electronical equipment. Siemens Healthcare GmbH has setup a Technical File in analogy to the requirements defined in IEC 63000 for "this component".
- ISO 13485:2016 (eq EU: EN ISO 13485:2016+AC:2016) — Medical devices – Quality management systems - Requirements for regulatory purposes
- ISO14971:2007 (eq Eu: EN ISO 14971 :2012) — Medical devices - Application of risk management to medical devices
- 21 CFR Part 1020, Performance standard for ionizing radiation emitting products, (USA)
- 21 CFR Part 820 Quality System Regulation, (USA)
- International Electrotechnical Commission (IEC), the following standards are considered especially:

Standard	Title
IEC 60601-1 :2012+C1:2012 (eq EU: EN 60601-1 :2006+AC:2010+A1:2013)	Medical electrical equipment - Part 1: General requirements for basic safety and essential performance
IEC 60601-1-2:2014 (eq EU: EN 60601-1-2:2015)	Medical electrical equipment - Part 1-2: General requirements for basic safety and essential performance - Collateral standard: Electromagnetic disturbances - Requirements and tests
IEC 60601-2-54:2015 (eq EU: EN 60601-2-54:2009+A1:2015)	Medical electrical equipment - Part 2-54: Particular requirements for the basic safety and essential performance of X-ray equipment for radiography and radioscopy
IEC 62304:2015 (eq EU: EN 62304:2006+AC:2008+A1:2015)	Medical device software - Software life cycle processes (EN: Corrected and reprinted in 2008-11)

1.1.4.2 Mini Console

The Mini Console has been manufactured and developed in agreement with the following laws, directives and design regulations:

- Council Directive 2011/65/EU of June 08, 2011 on the restriction of the use of certain hazardous substances in electrical and electronic equipment, following the requirements of harmonized standard EN 50581:2012 (RoHS)
- ISO 13485:2016 (eq EU: EN ISO 13485:2016+AC:2016) — Medical devices – Quality management systems - Requirements for regulatory purposes
- ISO14971:2007(eq EU: EN ISO 14971:2012) — Medical devices - Application of risk management to medical devices
- 21 CFR Part 1020, Performance standard for ionizing radiation emitting products, (USA)
- 21 CFR Part 820 Quality System Regulation, (USA)
- International Electrotechnical Commission (IEC), the following standards are considered especially:

Standard	Title
IEC 60601-1:2012+C1:2012 (eq EU: EN 60601-1:2006+AC:2010+A1:2013)	Medical electrical equipment - Part 1: General requirements for basic safety and essential performance
IEC 60601-1-2:2014 (eq EU: EN 60601-1-2:2015)	Medical electrical equipment - Part 1-2: General requirements for basic safety and essential performance - Collateral standard: Electromagnetic disturbances - Requirements and tests
IEC 60601-1-6:2010+A1:2013 (eq EU: EN 60601-1-6:2010)	Medical electrical equipment - Part 1-6: General requirements for basic safety and essential performance – Collateral standard: Usability

1.2 Safety Information

NOTICE

Risk of improper use of the high-voltage generator and the Mini Console.

When performing the work steps and checks, the general safety information for medical products must be observed.

- ⇒ Before handling the high-voltage generator or Mini Console, please carefully read the safety information contained in this document.

1.2.1 Installation, Repair, or Modifications



NOTE

Only qualified staff is permitted to unpack, install, and operate the generator unit and the Mini Console.



NOTE

Precautions to be observed before the first loading upon completion of the installation of an X-ray tube assembly, and special procedures for conditioning the X-ray tube, as appropriate.

Additions to the product must be made in accordance with the legal regulations and generally accepted engineering standards.

The manufacturer cannot accept responsibility for the safety features and for the reliability and performance of the equipment as the manufacturer, assembler, installer, or importer, if:

- installation, readjustments, or repairs are not carried out by persons authorized by us to do so,
- components affecting safe operation of the product are not replaced by original spare parts in the event of a malfunction,
- the electrical installation of the room does not meet the requirements of the VDE regulations or the corresponding national regulations, or the product is not used in accordance with the documentation.



WARNING

- ⇒ No modification of this equipment is allowed. Maintenance work may only be performed by the manufacturer's authorized customer service

NOTICE

We accept no responsibility for repairs performed without our express written approval.

- ⇒ We recommend that you obtain a report indicating the nature and the extent of the work performed from the persons carrying out such work.
- ⇒ The report should include all changes in rated parameters or operating ranges as well as the date, the name of the company and a signature.

1.2.2 Staff Qualification

1.2.2.1 Operating Staff

Using this product in accordance with regulations is only possible if the operating staff has the required specialized knowledge and is familiar with the operating instructions. These must be studied thoroughly before startup.

The operating staff should have practical training in the correct operation. The training should be repeated at appropriate intervals of time. It is recommended that emergencies are simulated and corresponding measures are trained.

1.2.2.2 Installation, Maintenance and Repair Staff

Only persons having expert knowledge of electrical systems and radiation protection are allowed to install, maintain, and adjust the product, electrical engineers or technicians, for example.

Furthermore, the installation and maintenance staff must have practical training in the installation, maintenance and repair of the product and be authorized by the distributor or manufacturer to perform this kind of work.

1.2.3 Safety Instructions

The generator and the Mini Console may only be operated in compliance with all safety instructions in this document. The system owner is responsible for compliance with the regulations that apply for the installation and operation of an X-ray system.

The hazards listed in this chapter are to be included in the technical documentation of the system.

1.2.3.1 Unpacking Hazards



WARNING

Improper unpacking and unrecognized shipment damages.

Risk of physical injury and system malfunctions.

- ⇒ Check the shipment for damage which could have an adverse effect on function and safety.
- ⇒ Use proper tools.
- ⇒ When cutting tensioning straps, secure the cut ends from lashing back.
- ⇒ Pull only nails out of the crate boards that have a cardboard or metal disk under the heads.
- ⇒ Pull nails out completely and dispose of them properly.
- ⇒ Wear sturdy shoes.
- ⇒ Follow the directional markings on the crates during transport, storage, and unpacking.

1.2.3.2 Installation Hazards

NOTICE

Risk of damage to property.

- ⇒ Do not install the generator unit and Mini Console before it has acclimatized to room temperature.
- ⇒ Compliance with general ESD directives must be ensured when handling the product.

NOTICE

Avoid improper lifting and moving of the heavy and bulky generator.

Recommendation when setting up the generator:

- ⇒ Wear protective clothing, e.g. safety shoes and gloves
- ⇒ At least two people are needed for lifting the generator.
- ⇒ If possible, use mechanical means for lifting the generator.

**WARNING**

Wrong installation.

Wrong installation may cause serious physical injury or death.

- ⇒ To avoid the risk of electric shock, this equipment must only be connected to a supply with protective earth.

**WARNING**

Wrong installation of protective earth.

Wrong installation of protective earth may cause serious physical injury or death.

- ⇒ The protective earth connection shall be tested after the installation of the generator.

1.2.3.3 Operating Hazards**WARNING**

Accessible voltages. Risk of electric shock.

Contact with accessible voltages may cause serious physical injury or death.

- ⇒ This equipment may only be operated, when all electrical connectors are installed completely.

**WARNING**

Accessible voltages.

Contact with accessible voltages may cause serious physical injury or death.

- ⇒ De-energize the system.
- ⇒ If checks or measurements require live-line working, cover energized parts to prevent unintentional contact.
- ⇒ Perform live-line working with extreme caution.
- ⇒ Use only measurement equipment and devices which are suited to the task.
- ⇒ Read and observe the safety labels.

**WARNING**

Accessible voltages.

Contact with accessible voltages may cause serious physical injury or death.

- ⇒ To avoid the risk of electric shock, this equipment must be disconnected from supply before opening.

**WARNING**

Accessible voltages.

Contact with accessible voltages may cause serious physical injury or death.

- ⇒ Before any work within the opened generator or at the XTA, the generator shall be disconnected from mains by opening the internal mains circuit breaker.

Remark: the switch off function of the generator does not disconnect the mains voltage from generator line input. After switch off all components of the generator and the XTA are still powered. After disconnect from mains, behind fuses F1-F3 all components of the generator and the XTA are deenergized.

**CAUTION**

Usage of wrong fuses.

Risk of fire.

- ⇒ Replace fuses only with same type and rating.

**CAUTION**

Being exposed to X-ray radiation without knowing it.

Risk of moderate injury caused by X-ray radiation.

- ⇒ Only enter the examination room, if the X-ray indicator is off.

**CAUTION**

Specified load limits of generator are exceeded.

Plastic smolders and produces toxic gases.

- ⇒ Limiting values for usage of the generator must not be exceeded.

**WARNING**

DC-link is powered.

Contact with line voltage may cause serious physical injury or death.

- ⇒ Remove the MRC cover only, when all LEDs on the MRC-board(s) are off.

NOTICE

Wrong power supply cords.

When setting up the generator

⇒ Only use power supply cords that meet the specifications.

1.2.4 Cleaning and Disinfection and Sterilization

1.2.4.1 High-voltage generator

This product does not require sterilization.



CAUTION

When cleaning the generator cover, liquids can seep into the generator.

Risk of generator defect.

- ⇒ Before cleaning the generator, shut down the system properly.
- ⇒ Do not spray the generator cover.
- ⇒ Avoid any liquid on the generator.

1.2.4.2 Mini Console

Cleaning:

- When cleaning and disinfecting, use suitable gloves for your own protection.
- Clean all contaminated parts and all parts which have come into contact with the patient directly or indirectly.
- When cleaning the console, use only a water-damp cloth.
- Dry it with a soft cotton cloth.
- Remove any contamination (such as contrast medium stains) immediately.
- Avoid scratches and shocks.
- Remove drops of water immediately; longer contact with water discolors the surface.

Disinfection:

- Disinfect all contaminated parts and all parts which have come into contact with the patient directly or indirectly.
- In addition, comply with the hygiene plan for your hospital.
- Disinfect the console by wiping only.

The Mini Console is resistant to cleaning agents and disinfectants.

For disinfection the following active ingredients are recommended:

- Quaternary compounds
- Guanidine derivatives



NOTE

The use of disinfectants other than those recommended can cause health impairments to the user and damage to the console.

Sterilization:

This product does not require sterilization.

1.2.5 Electromagnetic Compatibility

Medical electrical equipment needs special precautions regarding EMC.

EMC information provided in the accompanying documents must be followed where appropriate.



WARNING

Portable and mobile RF communications equipment can affect medical electrical equipment.

- ⇒ Use of accessories, transducers, and cables other than those specified or provided by the manufacturer of this equipment could result in increased electromagnetic emissions or decreased electromagnetic immunity of this equipment and result in improper operation.



WARNING

Risk of improper operation.

- ⇒ Use of this equipment adjacent to or stacked with other equipment should be avoided because it could result in improper operation. If such use is necessary, this equipment and the other equipment should be observed to verify that they are operating normally.



WARNING

Risk of performance degradation.

- ⇒ Portable RF communications equipment (including peripherals such as antenna cables and external antennas) should be used no closer than 30 cm (12 inches) to any part of the Polydoros RFX or connected components, including cables specified by the manufacturer. Otherwise, degradation of the performance of this equipment could result.

Product Specific Instructions regarding EMC

Following measures are necessary to maintain basic safety with regards to electromagnetic disturbances:

- The shields of all external cables, which are connected to the generator, shall be connected with shielding EMC clamps to the generator housing
- In case of defect or deformed housing EMC clamps, new housing EMC clamps shall be used instead
- The front metal sheets of all PCBs shall be connected with the respective screws to the generator housing
- The generator housing metal sheets shall be connected to the generator housing with the respective screws

1.2.5.1 Electromagnetic Emissions

The Polydoros RFX is considered as a component for which essential performance cannot be finally determined, because the functionality is depending on the intended use of the overall system.

The Polydoros RFX is intended for use in the electromagnetic environment specified below. The customer or the user of the Polydoros RFX should assure that it is used in such an environment.

**NOTE**

This equipment/system is intended for use by healthcare professionals only.

This equipment/system may cause radio interference or may disrupt the operation of nearby equipment.

It may be necessary to take mitigation measures, such as re-orienting or relocating the generator or shielding the location.

Emissions test	Compliance	Electromagnetic environment - guidance
Emissions CISPR 11	Group 1	The Polydoros RFX uses energy only for its internal function. Therefore, its emissions are very low and are not likely to cause any interference in nearby electronic equipment.
Emissions CISPR11	Class B	The Polydoros RFX is suitable for use in all establishments other than domestic and those directly connected to the public low-voltage power supply network that supplies buildings used for domestic purposes.
Harmonic current emissions IEC 61000-3-2	n.a.	
Voltage changes, voltage fluctuations, and flicker emissions IEC 61000-3-3	n.a.	

1.2.5.2 Electromagnetic Immunity**WARNING**

Risk of improper operation.

- ⇒ Use of this equipment adjacent to or stacked with other equipment should be avoided because it could result in improper operation. If such use is necessary, this equipment and the other equipment should be observed to verify that they are operating normally.

The Polydoros RFX is intended for use in the electromagnetic environment specified below. The customer or the user of the Polydoros RFX should assure that it is used in such an environment.

Immunity test	IEC 60601 test level	Compliance level	Electromagnetic environment - guidance
Electrostatic discharge (ESD) IEC 61000-4-2	±8 kV contact ±15 kV air	±8 kV contact ±15 kV air	Floors should be wood, concrete or ceramic tile. If floors are covered with synthetic material, the relative humidity should be at least 30 %.
Electrical fast transient/burst IEC 61000-4-4	±2 kV for power supply lines ±1 kV for input/output lines	±2 kV for power supply lines ±1 kV for input/output lines	Mains power quality should be that of a typical commercial or hospital environment.
Surge IEC 61000-4-5	±0.5 kV ±1.0 kV ±2.0 kV	±0.5 kV ±1.0 kV ±2.0 kV	Mains power quality should be that of a typical commercial or hospital environment.
Voltage dips, short interruptions and voltage variations on power supply input lines IEC 61000-4-11	0 % U_T 0.5 cycle at 0°, 45°, 90°, 135°, 180°, 225°, 270°, and 315° 0 % U_T 1 cycle 70 % U_T 25/30 cycles Single phase at 0°	Not applicable for products with 3-phase AC mains and input current rated with more than 16 A per phase.	Mains power quality should be that of a typical commercial or hospital environment. If the user of the product requires continued operation during power mains interruptions, it is recommended that the product be powered from an uninterruptible power supply or a battery.
Voltage interruptions IEC 61000-4-11	0 % U_T : 250/300 cycles	0 % U_T : 250/300 cycles	
Power frequency (50/60 Hz) magnetic field IEC 61000-4-8	30 A/m 50/60 HZ	30 A/m 50/60 HZ	
NOTE: U_T is the AC mains voltage prior to application of the test level.			

1.2.5.3 RF Immunity



WARNING

Risk of performance degradation.

- ⇒ Portable RF communications equipment (including peripherals such as antenna cables and external antennas) should be used no closer than 30 cm (12 inches) to any part of the Polydoros RFX or connected components, including cables specified by the manufacturer. Otherwise, degradation of the performance of this equipment could result.

The product is intended for use in the electromagnetic environment specified below. The customer or the user of the product should assure that it is used in such an environment.

Immunity test	IEC 60601 test level	Compliance level	Electromagnetic environment - guidance
Conducted disturbances induced by RF fields IEC 61000-4-6	3 V _{rms} 1 kHz 80 % AM 150 kHz to 80 MHz ISM frequencies	3 V _{rms} 150 kHz to 80 MHz ISM frequencies	
Radiated RF EM fields IEC 61000-4-3	3 V/m 1 kHz 80 % AM 80 MHz to 2.7 GHz	3 V/m	(-> see next table)
NOTE: These guidelines may not apply in all situations. Electromagnetic propagation is affected by absorption and reflection from structures, objects, and people.			

Field strengths from fixed transmitters, such as base stations for radio (cellular/cordless) telephones and land mobile radios, amateur radio, AM and FM radio broadcast and TV broadcast cannot be predicted theoretically with accuracy. To assess the electromagnetic environment due to fixed RF transmitters, an electromagnetic site survey should be considered. If the measured field strength in the location in which the product is used exceeds the applicable RF compliance level above, the product should be observed to verify normal operation. If abnormal performance is observed, additional measures may be necessary, such as reorienting or relocating the product.

Over the frequency range of 150 kHz to 80 MHz, field strengths should be less than 3 V/m.

Test frequency in MHz	Band in MHz	Service in MHz	Modulation	Immunity test level in V/m
385	380 - 390	TETRA 400	Pulse modulation: 18 Hz	27
450	430 – 470	GMRS 460, FRS 480	FM ±5 kHz deviation 1 kHz sine	28
710 745 780	704 – 787	LTE Band 13, 17	Pulse modulation: 217 Hz	9
810 870 930	800 – 960	GSM 800/900, TETRA 800, iDEN 820, CDMA 850, LTE Band 5	Pulse modulation: 18 Hz	28
1720 1845 1970	1700 - 1990	GSM 1800, CDMA 1900, GSM 1900, DECT, LTE Band 1, 3, 4, 25, UMTS	Pulse modulation: 217 Hz	28
2450	2400 – 2570	Bluetooth, WLAN, 802.11 b/g/n, RFID 2450, LTE Band 7	Pulse modulation: 217 Hz	28
5240 5500 5785	5100 - 5800	WLAN, 802.11 a/n	Pulse modulation: 217 Hz	9

1.2.6 Interfaces

Accessory equipment connected to the analog or digital interfaces must be certified according to the respective IEC standards (for example, IEC 950 for data processing equipment and IEC 60601-1:2012 (3.1rd edition) for medical equipment).

The use of other products/components not complying with the equivalent safety requirements of this medical electrical equipment may lead to a reduced level of safety of the resulting medical electrical system.

Consideration shall include:

- Evidence that the safety certification of the added products/components (medical electrical equipment) has been performed in accordance to the valid version of the IEC 60601 standard series and the relevant national deviations to this standard, if used in the patient vicinity.
- Everybody who connects additional products/components or medical electrical equipment to the signal input/output part configures a medical electrical system, and is therefore responsible that the medical electrical system in accordance to the IEC 60601-1 complies with the requirements of the valid version of the IEC 60601 standard series and the relevant national deviations to this standard.
- If in doubt consult your technical service department or local representative.

Combination with other Products/Components

To ensure the necessary safety, only products/components expressly approved by the manufacturer may be used in combination with the product.

To find out about the current state of the equipment and the combinations and upgrades currently approved:

- Please contact your authorized local sales representative

1.2.7 Maintenance

The high-voltage generator Polydoros RFX and the Mini Console are maintenance free. There are no hazards whatsoever for persons and environment in the case of proper use.

1.2.8 Checks

Checks after switching on the generator:

Perform a visual inspection of the Mini Console.

- The Power LED must be illuminated.
 - Safety feature -> in duplicate (2 LEDs)
 - In case only one LED is lit, replace the defective LED
- The radiation LED must not light up.
- In case of visible damage, the console must not be used.

Checks during Boot Routine:

The generator automatically performs self-tests and checks while booting. Any failure states will result in the error state of the generator.

Checks during Standby:

Perform a visual inspection of the Mini Console and check for error messages.

- Visual inspection of all displays/indicators on the console according to initial settings.
- The radiation indicator on the console or the radiation warning lights in the room must not light up.
- No error messages should occur.

Checks during examination:

Check the radiation LED.

- It may only light up during the duration of the X-ray exposure.

Checks before Exposure:

Perform a visual inspection of the indicators and control lights on the Mini Console.

- Visual inspection of all displays/indicators on the Mini Console according to initial settings.

Checks during Exposure:

Perform a visual inspection of the indicators and control lights on the Mini Console.

- Check the indicator for radiation. It may light up only during the duration of X-ray exposure.

Checks after Exposure:

The generator sends the actual values of kV, mAs, ms to the UI for post indication display.

Plausibility Check:

The system has to perform a plausibility check of sent and received exposure data.

Fault Tolerance Time:











The FTT (defined as the time between occurrence of failure and harm to patient or operator) is defined with 500 ms.









Multiple Fault Occurrence Time:





The MFOT (defined as the time after a first failure within which the probability for a second independent failure is sufficiently low) is defined with 24 h. Therefore, the generator has to be restarted at least once a day.



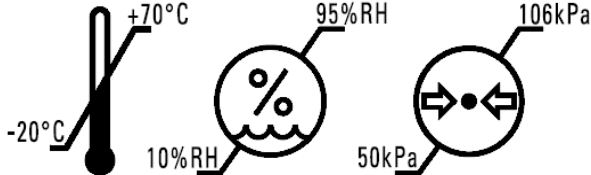
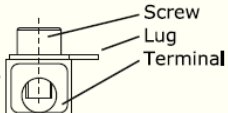

1.2.9 Labels and Pictograms on the Product and Package

1.2.9.1 High-voltage generator





Label	Meaning
<p>Polydoros RFX</p>  <p>(01) 4056869109817 GTIN (240) 11011021 MODEL (422) 276 ORIGIN DE (21) 10512 SERIAL</p> <p style="text-align: right;">IVK</p> <p>Siemens Healthcare GmbH, Henkestr. 127 91052 Erlangen, Germany</p> <p>Made in Germany</p>	<p>Identification label Polydoros RFX</p>
<p>HVT_LP_1</p>  <p>(01) 04056869062778 GTIN (240) 11011501 MODEL (422) 276 ORIGIN DE (21) 1001 SERIAL</p> <p style="text-align: right;">IVK</p> <p>Siemens Healthcare GmbH, Henkestr. 127 91052 Erlangen, Germany</p> <p>Made in Germany</p>	<p>Identification label HVT</p>
<p>Generator RC_LP_3PH</p>  <p>(240) 11011802 MODEL (422) 276 ORIGIN DE (21) 10512 SERIAL</p>	<p>Logistic material number label Polydoros RFX Low Power</p>
<p>Generator RC_HP_3PH</p>  <p>(240) 11011803 MODEL (422) 276 ORIGIN DE (21) 10512 SERIAL</p>	<p>Logistic material number label Polydoros RFX High Power</p>
<p>Service Part</p>  <p>(240) 11011601 MODEL (422) 276 ORIGIN DE (21) 10512 SERIAL</p>	<p>Identification label Service Part</p>
 <p>(1P) MODEL No.: 10910999</p>	<p>Identification label AMC box</p>
 <p>(1P) MODEL No.: 10910985</p>  <p>(S) SERIAL No.: 12345</p> 	<p>Identification label AMC</p>
<p>Generator RC_LP_3PH</p> <p>Contains: 11011021 Polydoros RFX</p>  <p>(01) 04056869116402 GTIN (240) 11011802 MODEL (422) 276 ORIGIN DE</p> <p>Siemens Healthcare GmbH, Henkestr. 127 91052 Erlangen, Germany</p> <p>Made in Germany</p>	<p>Product packing label Logistic material number (Low Power)</p>

Label	Meaning
<p>Generator RC_HP_3PH Contains: 11011021 Polydoros RFX</p>  <p>(01) 04056869123684 (240) 11011803 (422) 276</p> <p>GTIN MODEL ORIGIN DE</p> <hr/> <p> Siemens Healthcare GmbH, Henkestr. 127 91052 Erlangen, Germany</p> <p>Made in Germany</p>	<p>Product packing label Logistic material number (High Power)</p>
<p>RFX_High_Power_SCE</p>  <p>(01) 04056869232157 GTIN (240) 11011556 MODEL (422) 276 ORIGIN DE (21) 100815 SERIAL (20) 00 REV</p> <hr/> <p> Siemens Healthcare GmbH, Henkestr. 127 91052 Erlangen, Germany</p> <p>Made in Germany</p>	<p>Product packing label Shippable configuration elements (High power upgrade)</p>
<p>RFX_AMC_0_SCE</p>  <p>(01) 04056869237640 GTIN (240) 11011566 MODEL (422) 276 ORIGIN DE (21) 100901 SERIAL (20) 00 REV</p> <hr/> <p> Siemens Healthcare GmbH, Henkestr. 127 91052 Erlangen, Germany</p> <p>Made in Germany</p>	<p>Product packing label Shippable configuration elements (AMC)</p>
<p>RAD OEM Cable Set</p>  <p>(01) 04056869959900 (240) 11011497 (422) 276</p> <p>GTIN MODEL ORIGIN DE</p> <hr/> <p> Siemens Healthcare GmbH, Henkestr. 127 91052 Erlangen, Germany</p> <p>Made in Germany</p>	<p>Product packing label Cable set</p>
 <p>To reduce the risk of electric shock do not remove this panel until 2 minutes have elapsed after turning off the equipment. All LEDs on MRC-board(s) shall be off.</p> <p>Afin de réduire le risque de choc électrique, attendez 2 minutes après avoir éteint l'équipement avant de retirer ce panneau. Toutes les LED de la carte MRC devraient être éteintes.</p>	<p>Caution Risk of electric shock when panel is removed too early. Indicated waiting time: 2 min</p>

Label	Meaning																																																						
 <p>For continued protection against fire hazard replace fuses with the same type and rating only.</p> <p>Pour assurer la protection contre le risque d'incendie, les fusibles doivent être remplacés seulement avec le même type et la même valeur nominale.</p>	Fuse replacement																																																						
 <p>Live parts. Disconnect from supply before opening. Composants sous tension. Débranchez l'alimentation avant d'ouvrir.</p>	Caution Live parts, disconnect from supply before opening																																																						
<p>Mat. No. 11011021</p> <p>Rev 00 01 02 03 04 05 06</p>	Revision status label																																																						
<p>Rev. <input checked="" type="checkbox"/> 01 <input type="checkbox"/> 02 <input type="checkbox"/> 03 <input type="checkbox"/> 04 <input type="checkbox"/> 05 <input type="checkbox"/> 06 <input type="checkbox"/> 07 <input type="checkbox"/> 08 <input type="checkbox"/> 09 <input type="checkbox"/> 10 <input type="checkbox"/> 11 <input type="checkbox"/> 12 <input type="checkbox"/> 13 <input type="checkbox"/> 14 <input type="checkbox"/> 15 <input type="checkbox"/> 16 <input type="checkbox"/> 17 <input type="checkbox"/> 18 <input type="checkbox"/> 19 <input type="checkbox"/> 20 <input type="checkbox"/> 21 <input type="checkbox"/> 22 <input type="checkbox"/> 23 <input type="checkbox"/> 24</p>	Revision status AMC																																																						
<table border="1"> <tr> <td></td> <td><input type="checkbox"/></td> <td><input type="checkbox"/></td> <td><input type="checkbox"/></td> <td><input type="checkbox"/></td> <td><input type="checkbox"/></td> </tr> <tr> <td>POWER 3Ph kW:</td> <td>30</td> <td>40</td> <td>55</td> <td>65</td> <td>80</td> </tr> <tr> <td>POWER 1Ph kW:</td> <td>30</td> <td>40</td> <td>-</td> <td>-</td> <td>-</td> </tr> <tr> <td>MOMENT kVA:</td> <td>50</td> <td>70</td> <td>94</td> <td>102</td> <td>125</td> </tr> <tr> <td>LONG-TIME kVA:</td> <td>0.8</td> <td>0.8</td> <td>0.8</td> <td>0.8</td> <td>0.8</td> </tr> <tr> <td>3Phase</td> <td><input type="checkbox"/> 380V</td> <td><input type="checkbox"/> 400V</td> <td><input type="checkbox"/> 440V</td> <td colspan="2"><input type="checkbox"/> 480V</td> </tr> <tr> <td>1Phase</td> <td colspan="2"><input type="checkbox"/> 208V</td> <td colspan="3"><input type="checkbox"/> 240V</td> </tr> <tr> <td colspan="6">50/60Hz</td> </tr> <tr> <td colspan="6">Zutreffendes ankreuzen / mark appropriate box</td> </tr> </table>		<input type="checkbox"/>	<input type="checkbox"/>	<input type="checkbox"/>	<input type="checkbox"/>	<input type="checkbox"/>	POWER 3Ph kW:	30	40	55	65	80	POWER 1Ph kW:	30	40	-	-	-	MOMENT kVA:	50	70	94	102	125	LONG-TIME kVA:	0.8	0.8	0.8	0.8	0.8	3Phase	<input type="checkbox"/> 380V	<input type="checkbox"/> 400V	<input type="checkbox"/> 440V	<input type="checkbox"/> 480V		1Phase	<input type="checkbox"/> 208V		<input type="checkbox"/> 240V			50/60Hz						Zutreffendes ankreuzen / mark appropriate box						Connection label
	<input type="checkbox"/>	<input type="checkbox"/>	<input type="checkbox"/>	<input type="checkbox"/>	<input type="checkbox"/>																																																		
POWER 3Ph kW:	30	40	55	65	80																																																		
POWER 1Ph kW:	30	40	-	-	-																																																		
MOMENT kVA:	50	70	94	102	125																																																		
LONG-TIME kVA:	0.8	0.8	0.8	0.8	0.8																																																		
3Phase	<input type="checkbox"/> 380V	<input type="checkbox"/> 400V	<input type="checkbox"/> 440V	<input type="checkbox"/> 480V																																																			
1Phase	<input type="checkbox"/> 208V		<input type="checkbox"/> 240V																																																				
50/60Hz																																																							
Zutreffendes ankreuzen / mark appropriate box																																																							
	Transport and storage environmental conditions																																																						
<p>Mechanically sensitive tighten to 4.8 Nm</p>	Mechanically sensitive tighten																																																						
<p>This product complies with DHHS regulations 21 CFR Subchapter J, applicable at date of manufacture.</p> <p>Manufactured: MAY 2015 Siemens Healthcare GmbH Henkestr. 127, 91052 Erlangen Germany</p>	EPRC label																																																						
<p>Order of Assembly</p> 	Order of assembly																																																						
	Maximum load																																																						
	Warning High voltage																																																						

Label	Meaning
	Protective earth
	Sitting prohibited
 	<p>UL-Label</p> <p>Medical-application of electromagnetic radiation equipment with respect to electrical shock, fire and mechanical hazards only in accordance with: ANSI/AAMI ES60601-1 (2005) + AMD 1 (2012), CAN/CSA-C22.2 No. 60601-1 (2014), IEC 60601-1-3 (2013), CSA CAN/CSA-C22.2 No.60601-1-3-09 (2014) + AMD1 (2015), IEC 60601-1-6 (2013), CAN/CSA-C22.2 No. 60601-1-6A:11 + AMD1 (2015), IEC 60601-2-28 (2010), CAN/CSA-C22.2 No. 60601-2-28:12; IEC 60601-2-54:2009, AMD1:2015, CAN/CSA-C22.2 NO. 60601-2-54:11</p> <p>and</p> <p>Follow Instructions for Use</p>

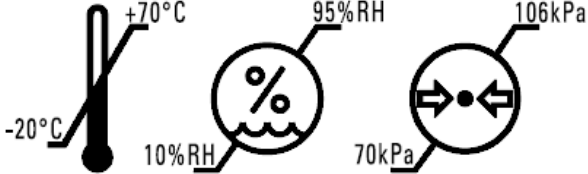
1.2.9.2 Mini Console

Label	Meaning
<p>Mini Console</p>  <p>(01) 04056869259833 GTIN (240) 11011500 MODEL (422) 276 ORIGIN DE (21) 10001 SERIAL</p> <p>Siemens Healthcare GmbH, Henkestr. 127 91052 Erlangen, Germany</p> <p>Rev. <input checked="" type="checkbox"/> 01 <input type="checkbox"/> 02 <input type="checkbox"/> 03 <input type="checkbox"/> 04 <input type="checkbox"/> 05 <input type="checkbox"/> 06 <input type="checkbox"/> 07 <input type="checkbox"/> 08 <input type="checkbox"/> 09 <input type="checkbox"/> 10 <input type="checkbox"/> 11 <input type="checkbox"/> 12 <input type="checkbox"/> 13 <input type="checkbox"/> 14 <input checked="" type="checkbox"/> 15 <input type="checkbox"/> 16</p> <p>Warning This X-ray unit may be dangerous to patient and operator unless safe exposure factors, operating instructions and maintenance schedules are observed.</p> <p>This product complies with DHHS regulations 21 CFR Subchapter J, applicable at date of facture. Manufactured: NOVEMBER 2019 Siemens Healthcare GmbH Henkestr. 127, 91052 Erlangen Germany</p>	<p>Identification label</p> <p>Revision label</p> <p>Radiation emission warning label</p> <p>EPRC label</p>
<p>Console_Package_0</p>  <p>(01) 04056869237657 GTIN (240) 11011590 MODEL (422) 276 ORIGIN DE (21) 100031 SERIAL (20) 00 REV</p> <p>Siemens Healthcare GmbH, Henkestr. 127 91052 Erlangen, Germany</p> <p>Made in Germany</p>	<p>Packaging label</p>
	<p>Transport and storage environmental conditions</p>
	<p>Original Siemens packing seal label</p>

1.2.9.3 Description of the Identification Label

1.2.9.3.1 High-voltage generator

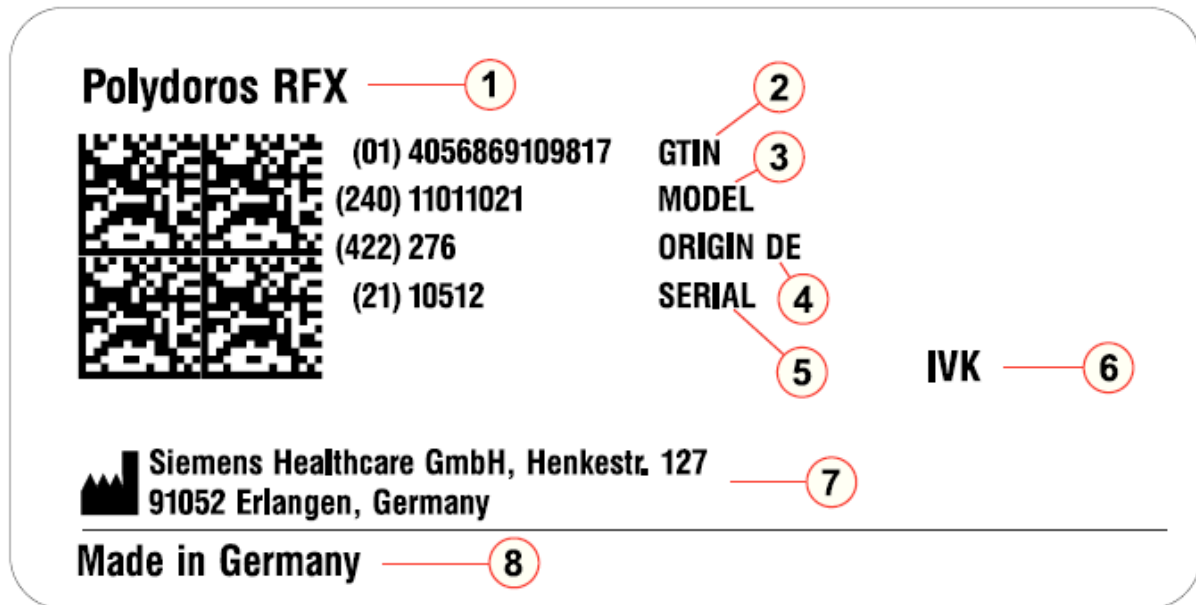

- (1) Product name
- (2) Global trade identification number
- (3) Model number
- (4) Country of origin code
- (5) Serial number
- (6) Identifier of selected system components or parts for product traceability
- (7) Legal manufacturer
- (8) Manufacturer's country

1.2.9.3.2 Mini Console

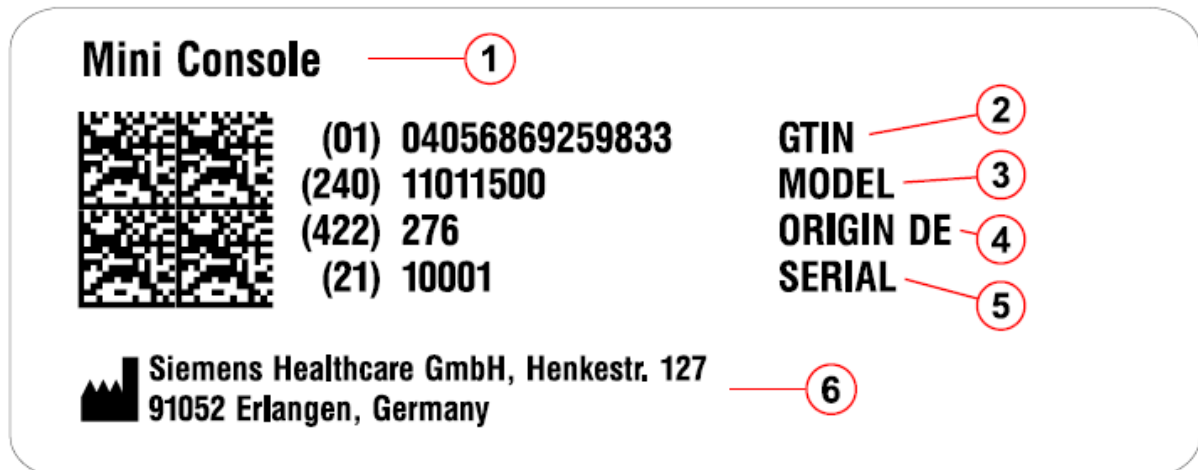

- (1) Product name
- (2) Global trade identification number
- (3) Model number
- (4) Country of origin code
- (5) Serial number
- (6) Legal manufacturer

1.2.9.4 Description of the Logistic Material Number Label

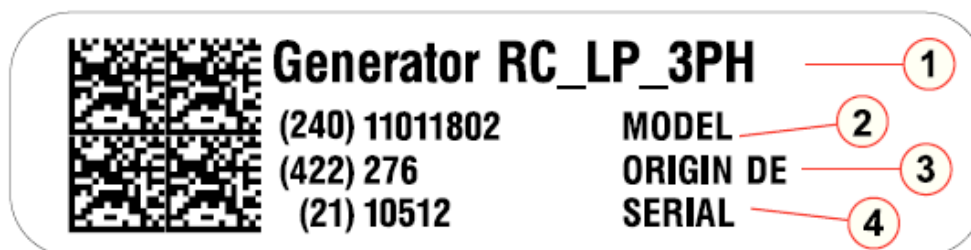

- (1) Product name
- (2) Model number
- (3) Country of origin code
- (4) Serial number

1.2.9.5 Description of the Product Packing Label for Logistic Numbers

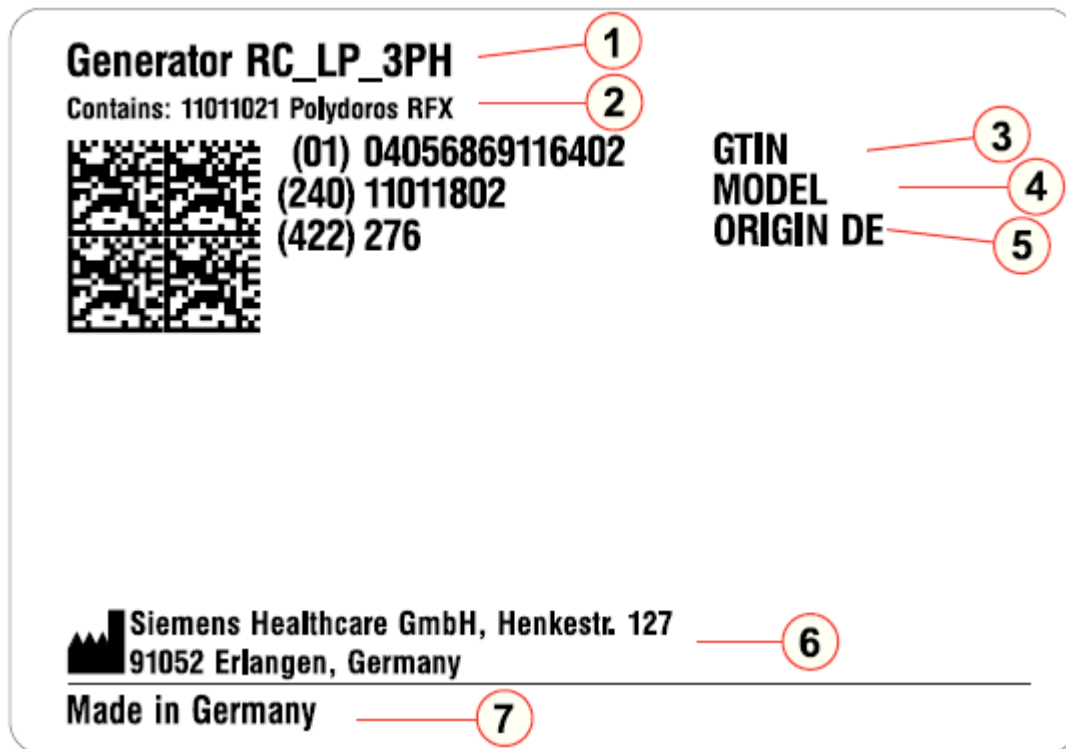

(1) Product name

(2) Usage

(3) Global trade identification number

(4) Model number

(5) Country of origin code

(6) Legal manufacturer

(7) Manufacturer's country

1.2.9.6 Description of the Product Packing Label for Shippable Configuration Elements

1.2.9.6.1 High-voltage generator

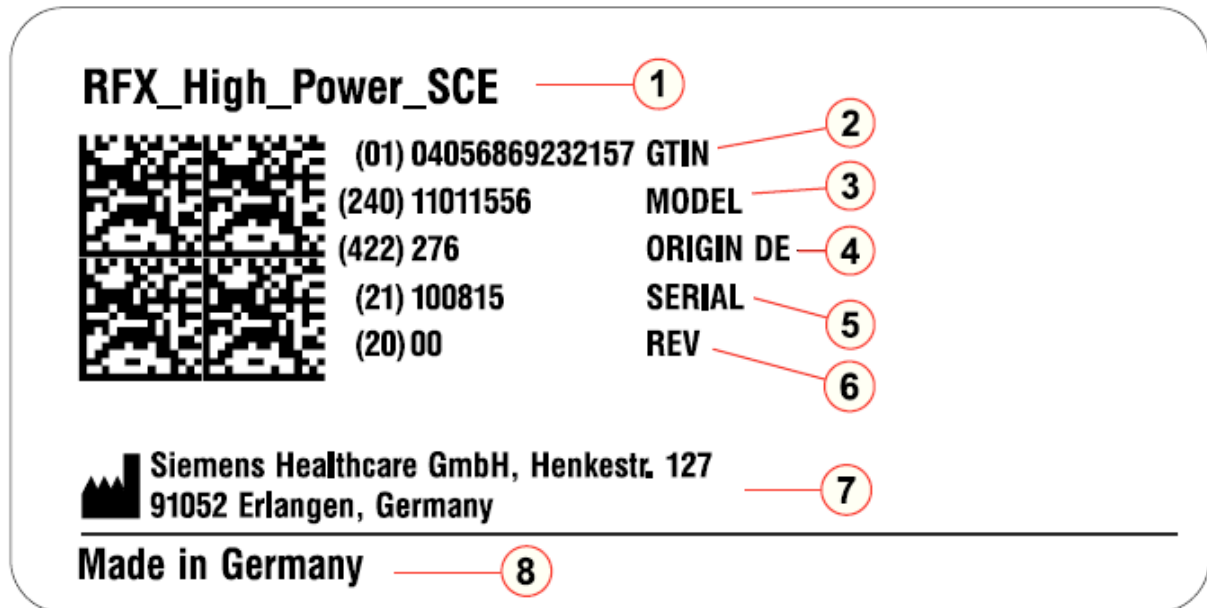

- (1) Product name
- (2) Global trade identification number
- (3) Model number
- (4) Country of origin code
- (5) Serial number
- (6) Revision number
- (7) Legal manufacturer
- (8) Manufacturer's country

1.2.9.6.2 Mini Console

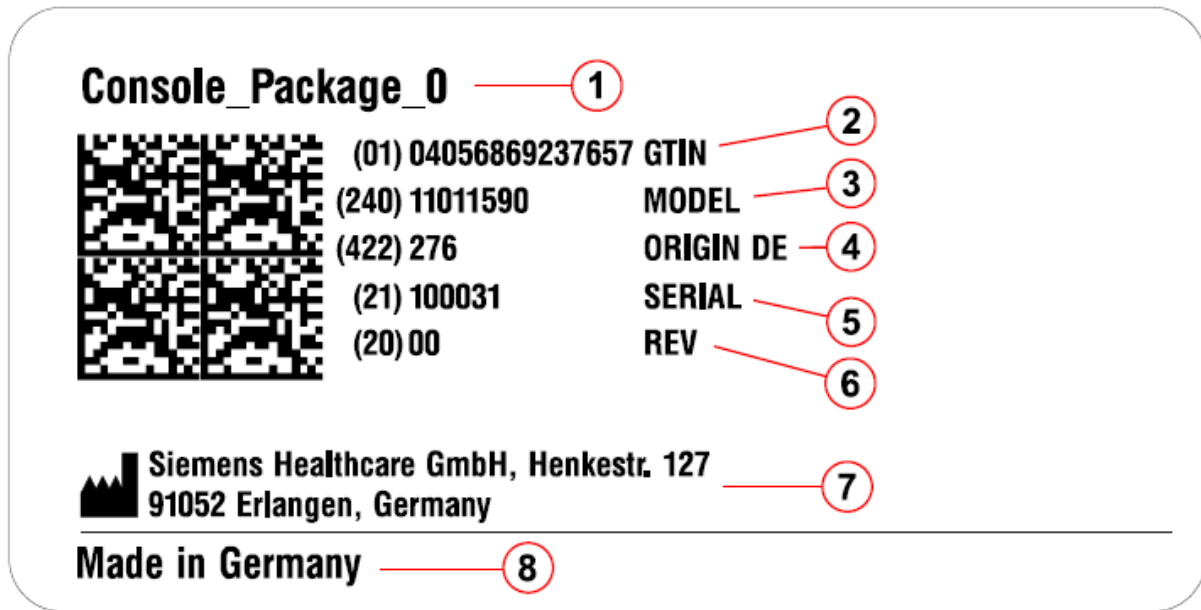

- (1) Product name
- (2) Global trade identification number
- (3) Model number
- (4) Country of origin code
- (5) Serial number
- (6) Revision number
- (7) Legal manufacturer
- (8) Manufacturer's country

1.2.9.7 Label Positions

1.2.9.7.1 Location of the Labels on the Polydoros RFX

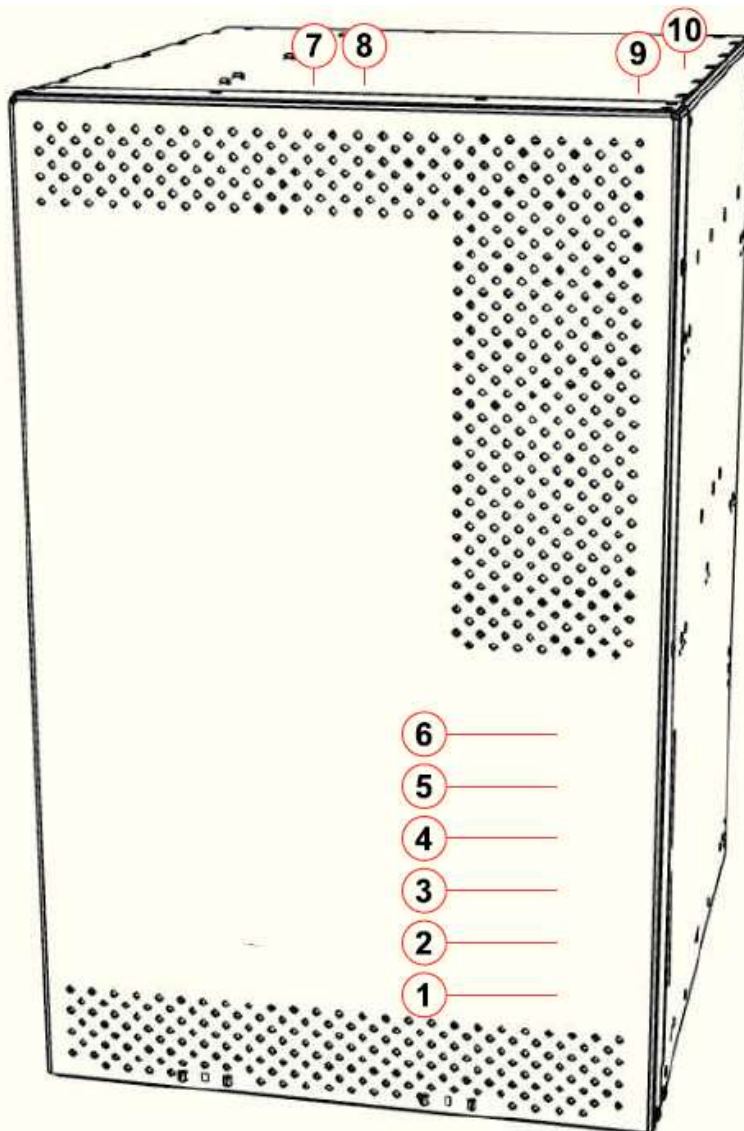

- (1) Identification label Polydoros RFX
- (2) Identification label (logistic numbers)
- (3) Shippable configuration elements (high power)
- (4) EPRC
- (5) UL
- (6) Dangerous Voltage
- (7) Max. load
- (8) Sitting prohibited
- (9) Live parts, disconnect from supply
- (10) Fuse replacement

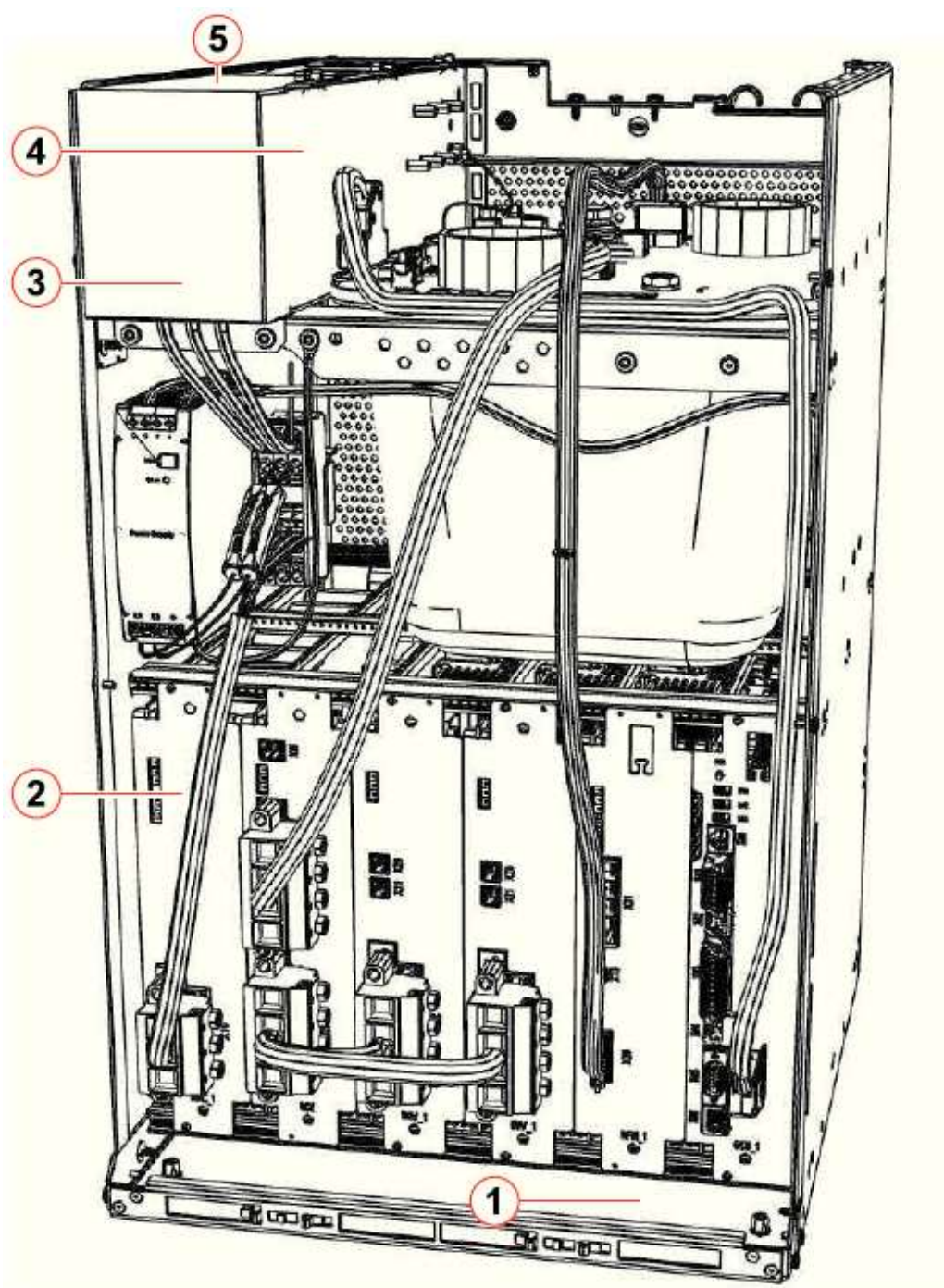

- (1) Identification labels (logistic numbers, high power, revision status, RFX)
- (2) Electric shock, waiting time
- (3) Fuse replacement
- (4) Electrical connection
- (5) Disconnection of supply voltage

1.2.9.7.2 Location of the Labels on the High-voltage Tank

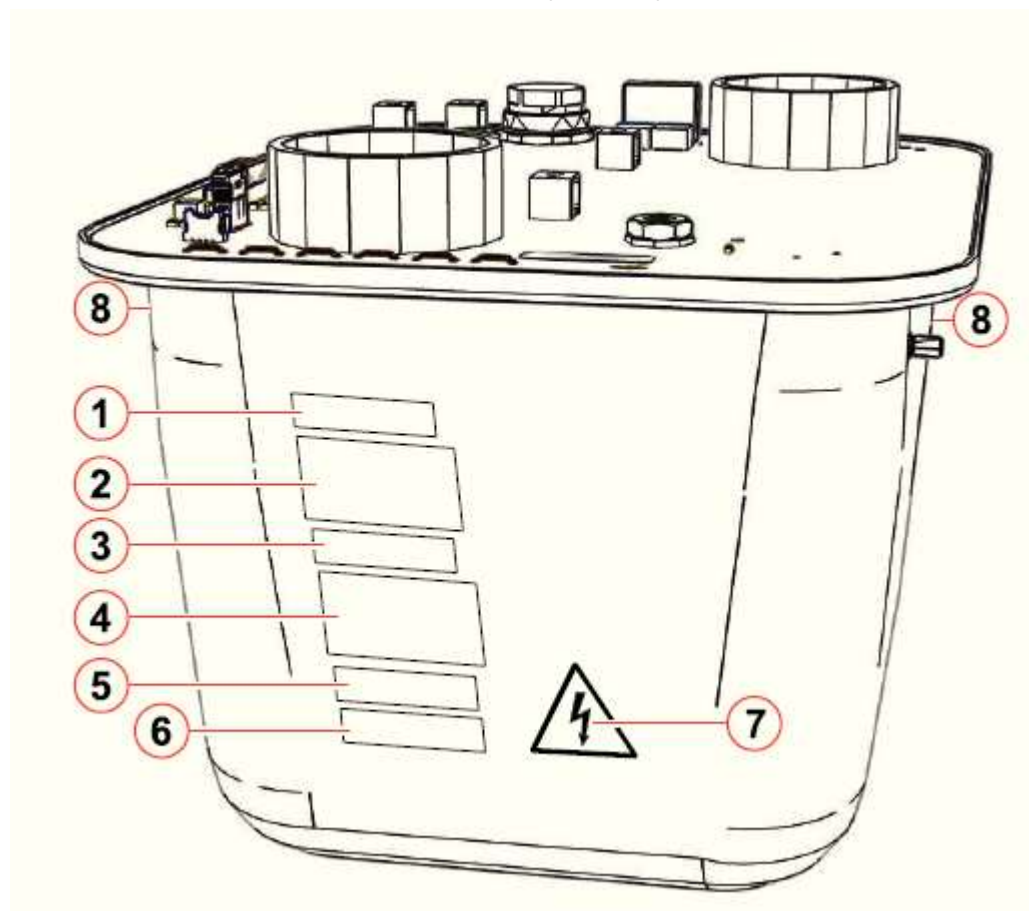

- (1) Service part identification
- (2) Identification label
- (3) Revision status
- (4) Safety – waiting time
- (5) Order of assembly
- (6) Mechanically tighten
- (7) Warning high voltage
- (8) Protective Earth (on both sides)

1.2.9.7.3 Location of the Labels on the AMC Box

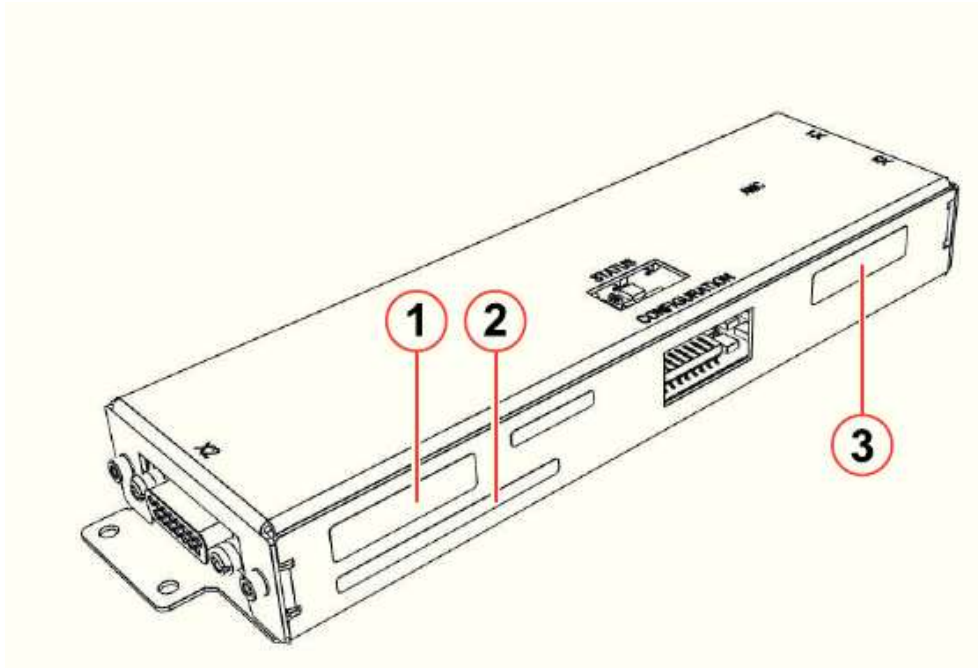

- (1) Identification label AMC
- (2) Revision status AMC
- (3) Identification label AMC box

1.2.9.7.4 Mini Console

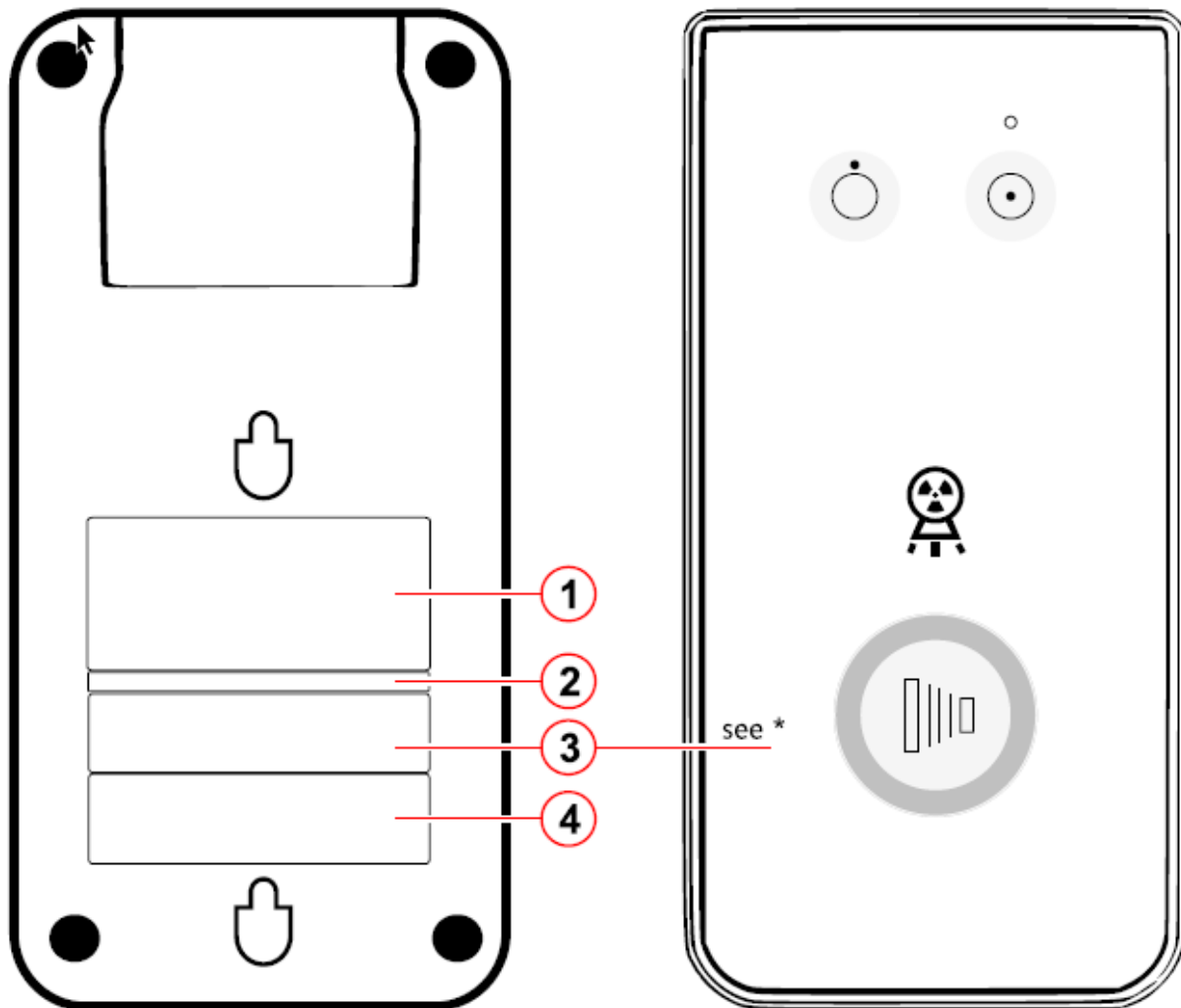

- (1) Identification label
- (2) Revision label
- (3) Radiation emission warning label
- (4) EPRC label

* Important information for additional "Radiation emission warning label" (position 3):

According to Title 21 U.S. Code of Federal Regulations §1020.30(j), the control panels of X-ray systems brought into U.S. interstate commerce shall bear the following warning statement, legible and accessible to view:

"Warning: This X-ray unit may be dangerous to patient and operator unless safe exposure factors, operating instructions and maintenance schedules are observed."

The assembler is responsible for attaching such label. For further information, please contact the Siemens Healthcare GmbH.

1.2.10 Disposal



NOTE

In order to comply with legal requirements concerning the environmental compatibility of our products (protection of natural resources and waste prevention) we endeavor to reuse parts and return them to the production cycle. Using the same extensive quality assurance measures as for factory-new components, we guarantee the functional efficiency, quality, and durability of these recycled parts.

The high-voltage generator Polydoros RFX contains materials such as oil and heavy metals for which environmentally friendly and proper disposal in accordance with the valid national legal regulations must be ensured.

Disposal as domestic or industrial waste is forbidden.

In the interest of complying with legal requirements concerning the environmental compatibility of our products (protection of natural resources, avoidance of waste), we endeavor to reuse components and to return them to the production cycle. We guarantee the functioning, quality and life of these components by taking extensive quality assurance measures, including all test procedures, just as for factory-new components.



CAUTION

Inappropriate disposal.

Pollution of the environment.

- ⇒ Dispose of waste material according to the national industry standards.
- ⇒ Take account of local regulations governing the disposal of the product.



CAUTION

Improper disposal of hazardous waste material.

Risk of injury and environmental damage.

- ⇒ The manufacturer will take the generator back for disposal.

Hazardous material

Quantity

Transformer oil

~7 l

2 Technical Data

2.1 Electrical Data

2.1.1 Mains Connection

Nominal line voltage	Nominal line voltage tolerance	Line connection	Line frequency
380 V	±10 %	3-phase, PE (N not needed)	50/60 Hz
400V			± 3 Hz
440V			
480 V			

2.1.2 Internal Line Resistance

Line voltage	Maximum internal line resistance ¹		
	@ 55 kW	@ 65 kW	@ 80 kW
380 V	0.15 Ω	0.15 Ω	0.10 Ω
400V	0.17 Ω	0.17 Ω	0.11 Ω
440V	0.20 Ω	0.20 Ω	0.14 Ω
480 V	0.24 Ω	0.24 Ω	0.16 Ω

1. According to IEC 60601-2-54.

2.1.3 Fuses Overview

Fuse	Location	Type	Value	Material number
F1, F2, F3	MFF	NH (LV HRC)	50 A gG	10965624
F4, F5 (in cable X100)	X100	SHT6.3x32	15 A T	11011471

2.1.4 Performance Data

2.1.4.1 High-voltage generator

Performance data	
High voltage	40 kV to 150 kV
High-voltage steps	1.0 kV
High-voltage rise time ¹	≤ 1 ms @ ≤ 150 kV
High-voltage form	Multipulse
High-voltage cable length	16 m
Tube current	10 mA to 800 mA (55/65 kW) 10 mA to 1000 mA (80 kW)
Exposure time	1 ms to 5000 ms
Minimum exposure time	1 ms @ 100 kV (1-point technique) 1 ms @ 100 kV (2-point technique) 20 ms @ 100 kV (3-point technique)
Tube current time product	0.5 mAs to 800 mAs (55/65 kW) 0.5 mAs to 1000 mAs (80 kW)
Tolerances kV accuracy mA accuracy ms accuracy mAs accuracy IEC 60601-2-54	± 5 % ± (5 % + 0.1 mA) ± (10 % + 1 ms) ± (10 % + 0.2 mAs)
X-ray techniques / operation modes IEC 60601-1	Single exposure 1-point technique with falling load Single exposure 2-point technique with constant load Single exposure 3-point technique with constant load
Nominal shortest irradiation time (only for 1-point technique)	≥ 3 ms (in combination with AMC module 10910985 + AEC chamber 10664935, anti-scatter grid, large focus, 80 % power)
Energy limitation	56 kW
Noise emission	≤ 70 dB(A)

1. For the kV voltage range from 50 kV - 80 kV for tube currents $I_t > 850$ mA the rise time is < 2 ms

Tube voltage	Maximum tube current ¹		
	@ 55 kW	@ 65 kW	@ 80 kW
40 kV	800 mA	800 mA	800 mA
60 kV	800 mA	800 mA	1000 mA
80 kV	687 mA	800 mA	1000 mA
100 kV	550 mA	650 mA	800 mA
120 kV	458 mA	541 mA	650 mA
125 kV	440 mA	520 mA	640 mA
150 kV	366 mA	433 mA	533 mA

1. For large focus and 100 ms exposure time. Maximum applicable values for the XTA may differ.

	Output power ¹
800 mA @100 kV,100 ms	80 kW
650 mA @100 kV,100 ms	65 kW
550 mA @100 kV,100 ms	55 kW

1. According to EN 60601-2-54

Type	Apparent power
Long-term (Standby)	$\leq 0.8 \text{ kVA}^1$

1. Without power consumption of external connections

Type	Apparent power		
	@ 55 kW	@ 65 kW	@ 80 kW
Short-term (Operation)	$\leq 94 \text{ kVA}$	$\leq 108 \text{ kVA}$	$\leq 127 \text{ kVA}$

2.1.4.2 Mini Console

Performance data	
Power ON/OFF button	Switching on/off the generator (+24 V circuit)
Power LED (green)	Indicates if the generator is powered on (safety feature → in duplicate (2 LEDs))
Exposure button	Releasing X-ray (2 stages: pre/main contact)
Radiation LED (yellow)	Lights up if radiation is triggered
Radiation buzzer	The buzzer drive signal is provided by the generator independently from the radiation status LED
Hand switch (for future use)	An external hand switch can be connected
Mounting holes	The console can be wall mounted via two mounting holes

2.2 Mechanical Data

2.2.1 Hardware Configuration

Depending on the generator model, the Polydoros RFX is available in two different slide-in module configurations:

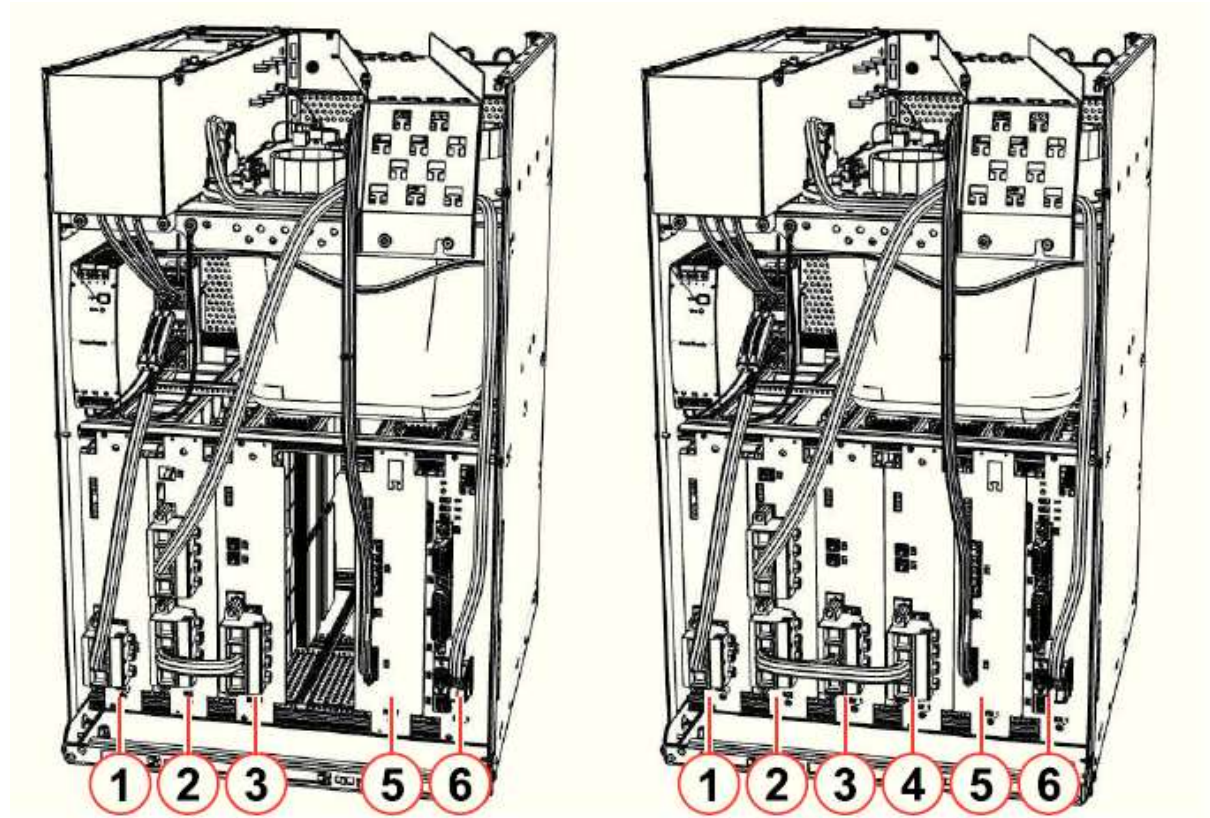

	Low Power configuration:	High Power configuration:
(1) Mains rectifier and capacitor	MRC_1	MRC_1
(2) Resonant circuit extension	RCE_2	RCE_1
(3) Inverter	INV_1	INV_1
(4) Inverter	n.a.	INV_1
(5) RAC, filament, and miscellaneous	RFM_1	RFM_1
(6) Generator control board	GCB_1	GCB_1



NOTE

For the horizontal generator design, an external cooling must be installed.

2.2.2 Dimensions and Weight

Polydoros RFX		Vertical design	Horizontal design
Dimensions	Width	374 mm	602 mm ¹
	Height	602 mm	374 mm
	Depth ²	442 mm	442 mm
Weight	Generator	< 78kg	< 78kg

1. External cooling fan not considered.

2. Mains inlet not included. With consideration of the mains inlet, the depth is 496 mm.

Mini Console		
Dimensions	Width	89.7 mm
	Length	180 mm
	Height	39.5 mm
Weight		0.26 kg

2.2.3 Paint color

Paint color	
Generator cabinet	White
Mini Console housing	White

2.2.4 Control and Display Elements

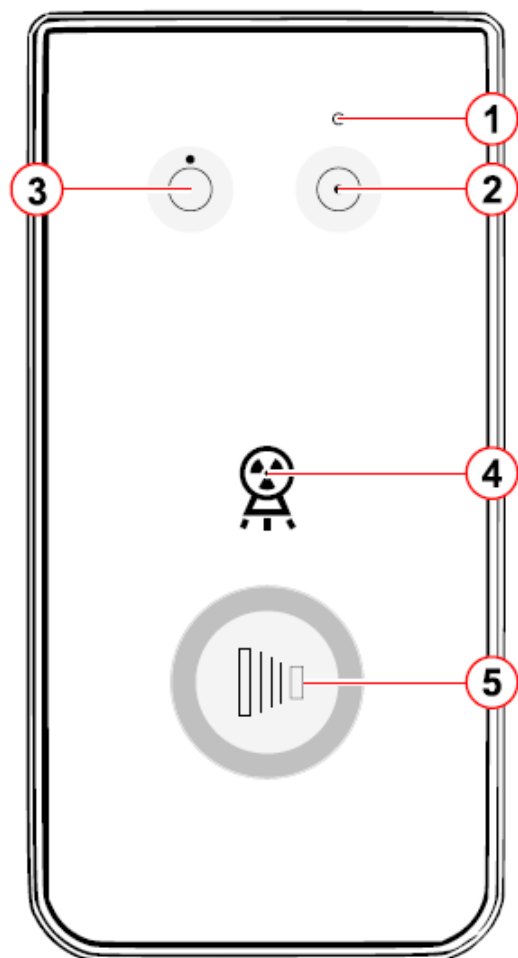

(1) Power LED (green)



(2) Power ON button



(3) Power OFF button



(4) Radiation LED (yellow)



(5) Exposure button

2.2.5 Interfaces of the Mini Console

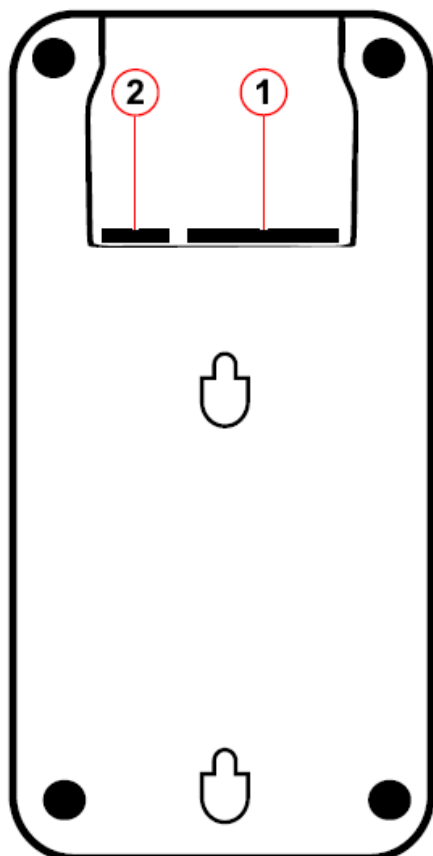

Interface:	Type:
(1) Generator (X1)	HD D-Sub DE-15, male
(2) Hand switch (X2)	RJ-10 4P4C



NOTE

The X1 cable supplied with the Mini Console must be used to connect the generator. The X2 cable is part of the external hand switch (for future use).

2.3 Dimensional Drawings

2.3.1 Mini Console Dimensions

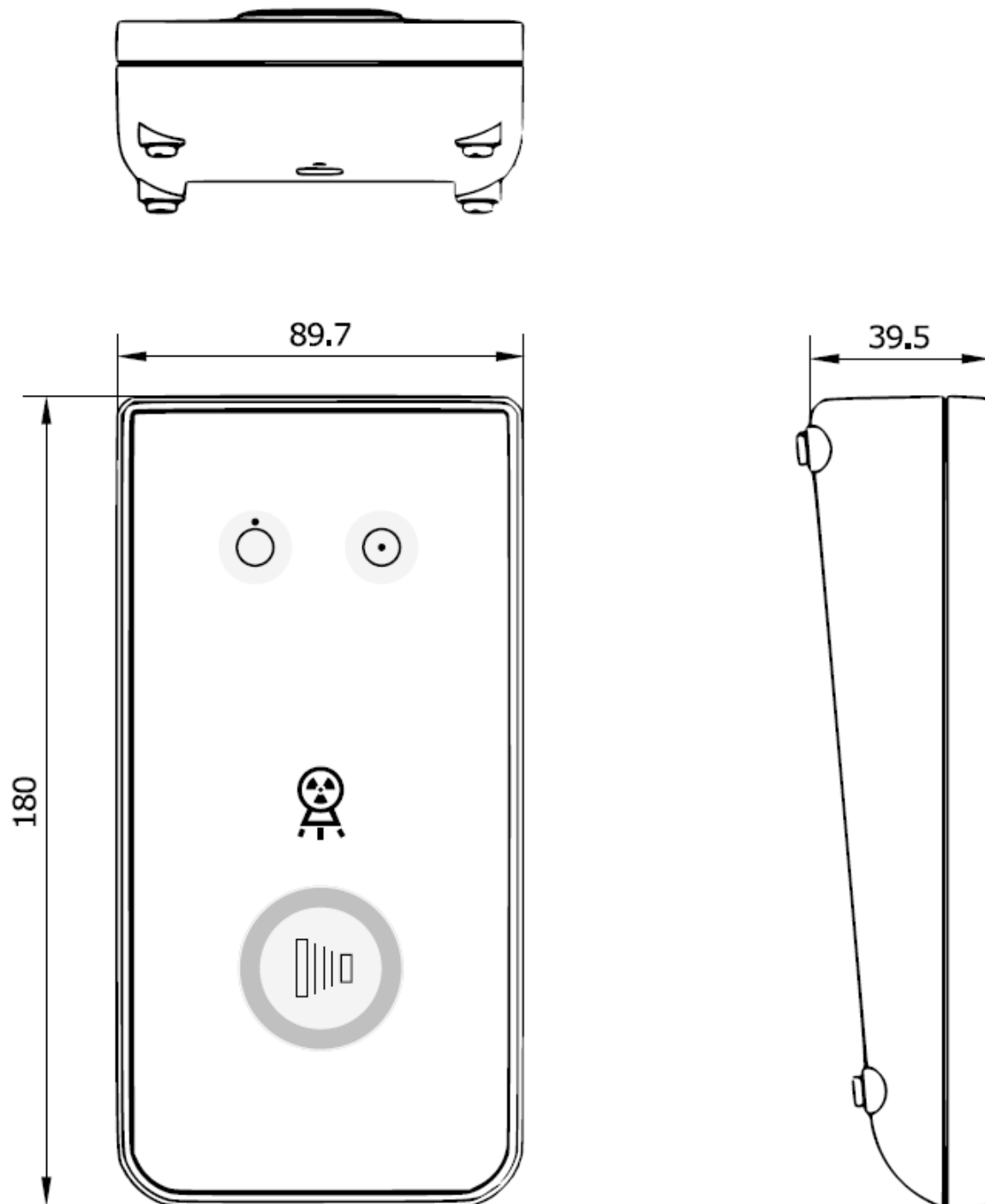

2.3.2 Mounting Hole Dimensions

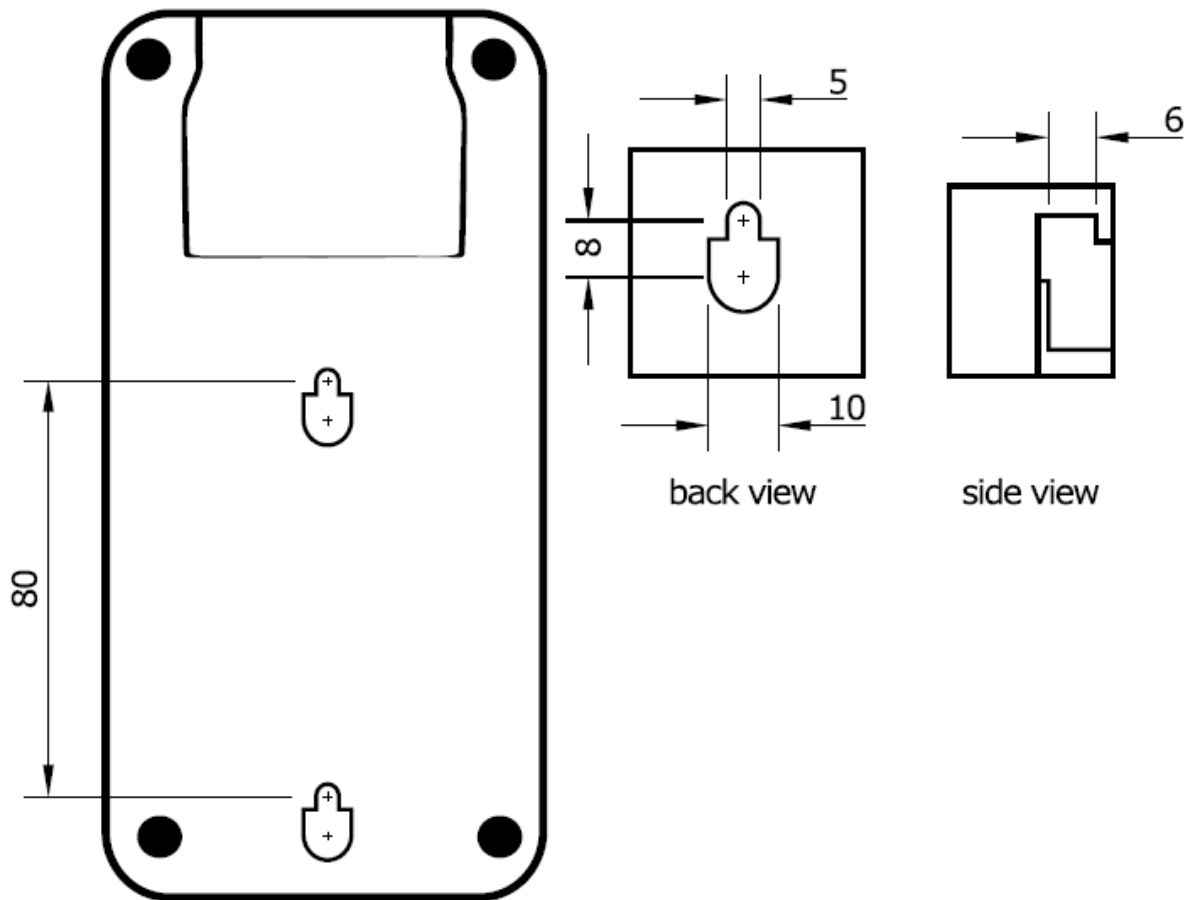

2.3.3 Vertical Design

Dimensions of the generator cabinet: vertical design:

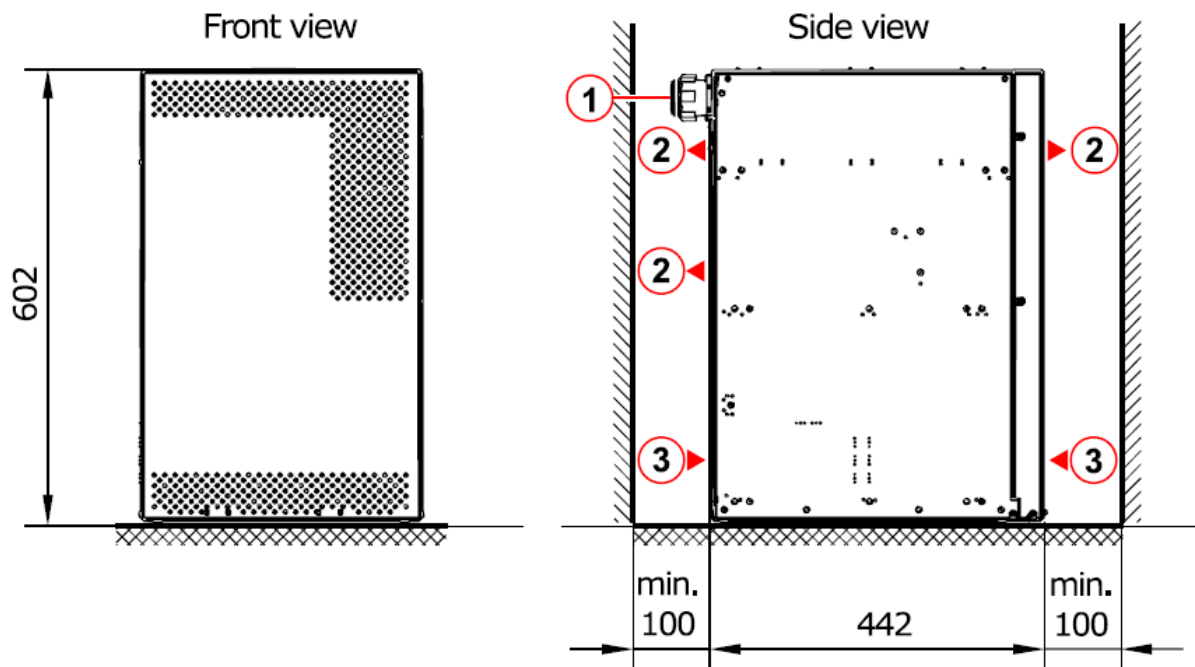

Dimensions of the generator cabinet: vertical design top view:

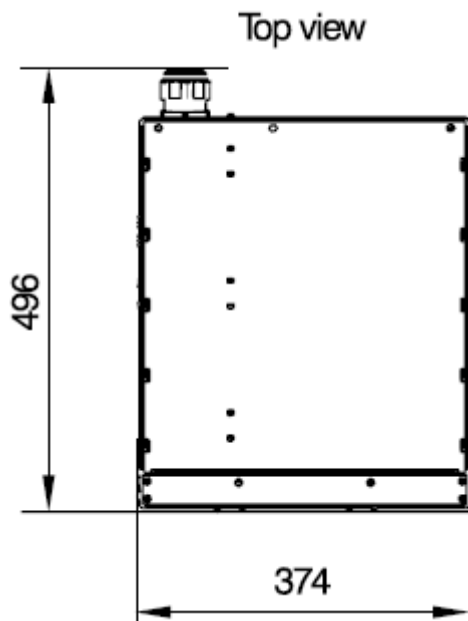

- (1) Mains inlet
- (2) Air outlet
- (3) Air intake

2.3.4 Horizontal Design

Dimensions of the generator cabinet: horizontal design:

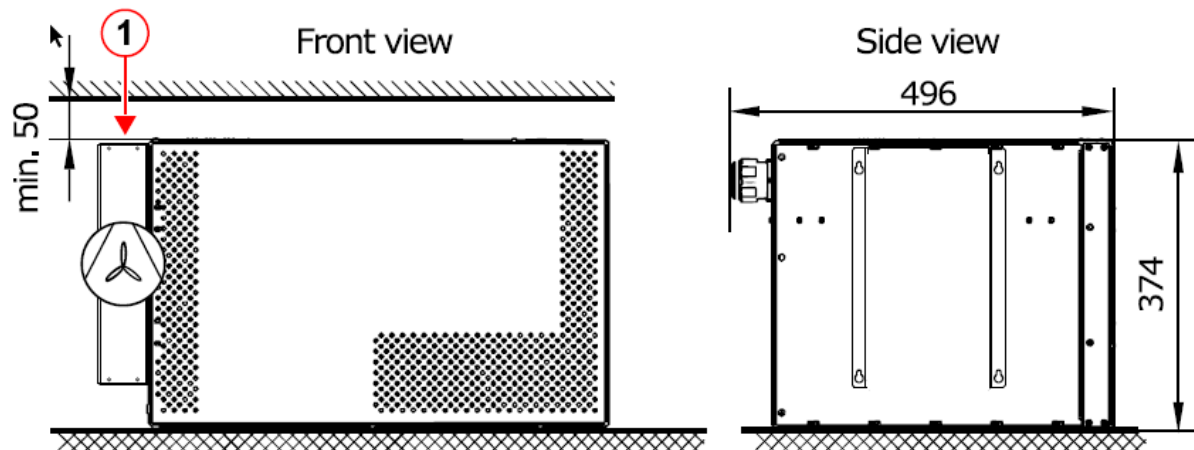

Dimensions of the generator cabinet: horizontal design top view:

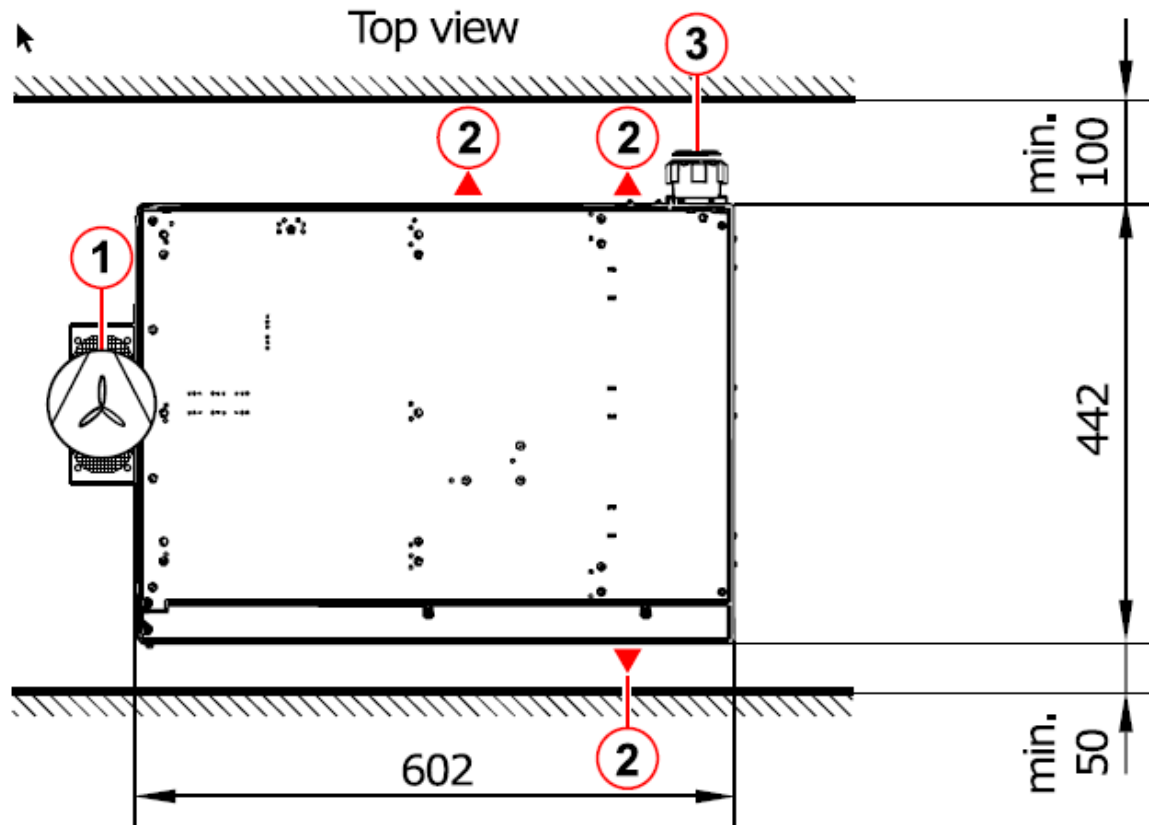

- (1) External cooling fan
- (2) Air outlet
- (3) Mains inlet

2.3.5 Room Planning

NOTICE

Please note the following room planning information when setting up the generator:

- ⇒ It is not allowed to close or cover up the ventilation slots.
- ⇒ The bending radius of the used mains supply lines shall be considered (e.g. min. 185 mm for 5 x 35 mm²).
- ⇒ For the horizontal generator design, an external cooling fan must be installed:
 - To ensure a sufficient cooling of the generator, an air flow rate of 25m³/h must be ensured.

2.4 Environmental Conditions

2.4.1 Transport and Storage Conditions

2.4.1.1 High-voltage generator

Admissible ambient temperature	-20 °C to +70 °C
Admissible relative humidity	10 % to 95 % (Without condensation)
Admissible barometric pressure	500 hPa to 1060 hPa

2.4.1.2 Mini Console

Admissible ambient temperature	-20 °C to +70 °C
Admissible relative humidity	10 % to 95 % (Without condensation)
Admissible barometric pressure	700 hPa to 1060 hPa

2.4.2 Operating Conditions

2.4.2.1 High-voltage generator



NOTE

The Polydoros RFX must not be operated below an ambient temperature of +10 °C.

Admissible ambient temperature	+10 °C to +40 °C
Admissible relative humidity	20 % to 75 % (Without condensation)
Admissible barometric pressure	700 hPa to 1060 hPa
Rated operating altitude	≤ 3000 m
IEC 60601-1	

2.4.2.2 Mini Console

Admissible ambient temperature	+10 °C to +40 °C
Admissible relative humidity	30 % to 75 % (Without condensation)
Admissible barometric pressure	700 hPa to 1060 hPa
Rated operating altitude	≤ 3000 m
IEC 60601-1	

2.5 Classification

2.5.1 High-voltage generator

EMC class IEC 60601-1-2	B
Protection category IEC 60601-1	I
Degree of protection EN 60529	IP20
Degree of protection	No application with flammable gas (No AP, APG certificated)
Transport class IEC 60721-3-2	2M4
Overvoltage category IEC 60601-1	II 2500 V _{peak}
Material group Comparative tracking index (CTI) EN60601-1: 2006	III b 100 ≤ CTI ≤ 175
Pollution degree IEC 60601-1	2
Expected service life IEC 60601-1	10 years
RoHS EN 50581	✓

2.5.2 Mini Console

Degree of protection	No application with flammable gas (No AP, APG certificated)
RoHS EN 50581	✓

Further classification statements are dependent on the overall context of the system periphery.

3 Console Operation

3.1 Switching On/Off the Generator

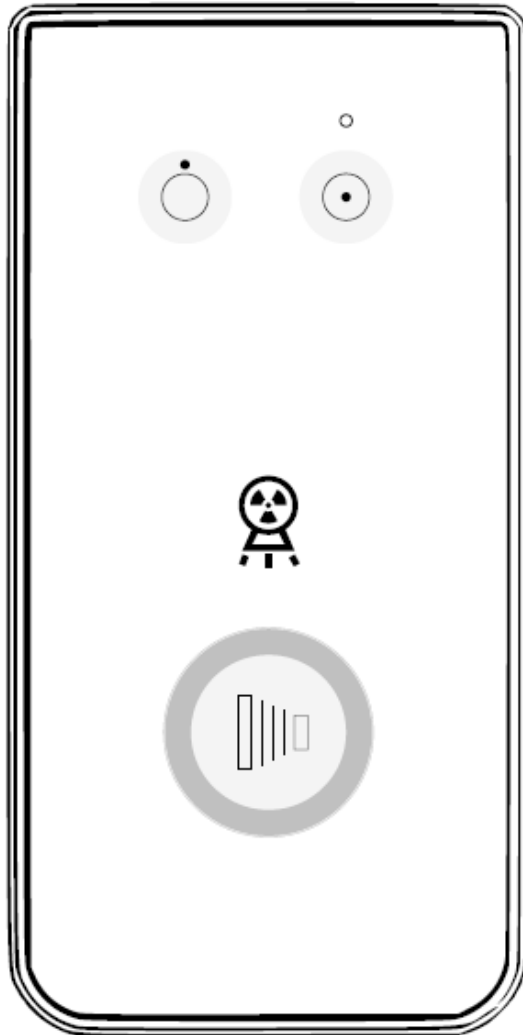

Press the ON button ⇒ the generator is switched on



Press the OFF button ⇒ the generator is switched off



NOTE

The power-on status of the generator is indicated by the green power LED above the ON button.

3.2 Exposure Release

The exposure is released either with the exposure button integrated in the Mini Console or with the hand switch (optional).



NOTE

Before releasing X-ray, check the selected acquisition data at the workstation. For X-ray release, the workstation must be in ready state.

Preparations (pre contact):



Exposure button:

Press the exposure button down to the first pressure point and hold it approx. 1 sec



Hand switch:

Press the exposure button down to the first pressure point and hold it approx. 1 sec

- The rotating anode is accelerated to nominal speed
- The required filament current is set



NOTE

After warming up the filament and accelerating the rotating anode, it is possible to release X-ray.

Radiation release (main contact):



Exposure button:

Press the exposure button down fully and keep it pressed until the exposure is ended



Hand switch:

Press the exposure button down fully and keep it pressed until the exposure is ended



NOTE

Releasing the exposure button immediately ends the X-ray.

X-ray indication:



NOTE



The radiation LED on the control console lights up and a buzzer signal sounds during exposure release.

Do not release the exposure button or the handswitch until 2 seconds after termination of the buzzer signal, otherwise an error message will appear.

4 Software Operation



NOTE

Detailed information please find in the enclosed installation- and User Manual CONAXX 2.

4.1 Software X-ray Generator Control























4.2 Parameters of the Software X-ray Generator Control

The user can activate different patient anatomies with these buttons:

♤: "child ♤", "thin ♤", "normal ♤" and "thick ♤"

The following functions can be used in this area:

-  - Organ program "child"
-  - Organ program "thin"
-  - Organ program "normal"
-  - Organ program "thick"
-  - Work station "free "
-  - Work station "table"
-  - Work station "wall "
-  - Exposure technique "1-point":
kV & measurement chamber

- 
- **Exposure technique "2-point":**
kV & mAs
- 
- **Exposure technique "3-point":**
kV & mA & ms
- 
- **Focus "small"**
- 
- **Focus "large"**
- 
- **Measurement chamber "left"**
- 
- **Measurement chamber "middle"**
- 
- **Measurement chamber "right"**
- 
- **Tube energy "low"**
- 
- **Tube energy "normal"**
- 
- **Density**
- 
- **Increase parameter:**
Increases a parameter, e.g. kV.
- 
- **Decrease parameter:**
Decreases a parameter, e.g. kV.
- 
- **Toggle parameter:**
Toggles through all possible values of a parameter.

5 Error messages

The software CONAXX 2 will display error messages if the generator has an abnormal status. This chapter contains a table for those messages and suggests actions to be taken.

Error ID	Error message	Action
0x1BE (446)	The submodule RCE has exceeded temperature of 70°C	Switch off generator and cool down
0x19F (415)	The submodule RCE has a broken temperature sensor.	Reset error and restart generator If this occurs repeatedly, contact a service technician
0x202 (514)	The operator has opened the door during exposure	-
0x203 (515)	The XTA has reached maximum temperature / pressure	Cool down XTA
0x204 (516)	The XTA temperature has reached 70°C	No action necessary
0x210 (528)	Internal SW error: HW selftest wrong step.	Reset error and restart generator
0x211 (529)	Internal SW error: HW selftest not allowed.	Reset error and restart generator
0x222 (546)	The door contact is open during selftest	-
0x225 (549)	The requested tube current is too high.	Check exposure settings
0x226 (550)	The requested tube current is too low.	Check exposure settings
0x227 (551)	The requested tube voltage is too high.	Check exposure settings
0x228 (550)	The requested tube voltage is too low.	Check exposure settings
0x246 (582)	The exposure shall not be interrupted by the user by releasing the exposure button.	Do not release button during exposure
0xD00 (3328)	Adapter detected implausible exposure parameters	Check exposure settings
0xD01 (3329)	Internal SW error: Communication error between Adapter and generator software	Restart generator
0xD02 (3330)	An error occurred in calculation of dose compensation	Check exposure settings



NOTE

When other errors appear, please contact a PROTEC authorized service technician.