

OPTIMAX

OPTIMAX Mammo

Automated X-ray film processor

Model/ID: 117x-x-x000
Basic UDI-DI: 426050264A001UA

Instructions for use

Ident. no. 5170-0-0002



**NOTE**

All sheets of this document contain proprietary and confidential information of PROTEC X-ray Systems GmbH and is intended for exclusive use by current PROTEC X-ray Systems GmbH customers. Copying, disclosure to other or other use is prohibited without the express written authorization of PROTEC's law department. Report any violations of this requirement to PROTEC X-ray Systems GmbH.

© 2025 PROTEC X-ray Systems GmbH, Oberstenfeld

Comments and questions about the documentation please contact:

PROTEC X-ray Systems GmbH

In den Dorfwiesen 14, 71720 Oberstenfeld
Germany

Tel: (+ 49) 7062 – 92 55 0

Fax: (+ 49) 7062 – 92 55 60

E-Mail: protec@protec-med.com

Internet: www.protec-med.com

Table of contents

	Page
Table of contents	3
Revision Status	5
General Notes	6
Mechanical and Electric Warning	6
To the User	6
1 Device Description	8
1.1 Introduction	8
1.2 Description.....	8
1.2.1 Versions	8
1.2.2 Installation	8
1.3 Performance Characteristics	9
1.4 Intended Use	9
1.5 Clinical Benefit	9
1.6 Patient Target Group(s)	9
1.7 Medical Conditions to be diagnosed	9
1.8 Indications and Contraindications	10
1.8.1 Indication.....	10
1.8.2 Contraindication	10
1.9 Intended User Group.....	10
1.10 Declaration of Conformity.....	10
2 Safety Instructions	11
2.1 General Safety Instructions	12
2.1.1 Requirements for Operation	12
2.1.2 Device Operation	12
2.1.2.1 Operating Type	12
2.1.3 Operating Personnel	13
2.1.4 Ventilation.....	13
2.1.5 Explosion Protection	13
2.1.6 Interaction with Other Devices.....	13
2.1.7 Electromagnetic Environment and influencing of Devices	13
3 Control Elements and Displays	14
3.1 Main switch of the automated X-ray film processor.....	14
3.2 Control Elements and Displays of the automated X-ray film processor.....	14
3.2.1 Standard Controls and Displays	14
4 Handling	15
4.1 Operation of the automated X-ray film processor	15
4.1.1 Before starting	15
4.1.2 Working procedure	16
4.1.3 After work.....	16
4.1.4 Stand-by mode.....	16
4.1.5 Switching on the device	16
4.1.6 Bath temperature	16
4.1.7 Display "Infeeding film"	16
4.1.8 Manual pumping.....	16
4.1.9 Anti-crystallization function.....	17
4.1.10 Time replenishment	17
4.1.11 Automatic replenishment.....	17
4.2 Function of the automated X-ray film processor	17
4.2.1 Switching the automated X-ray film processor on and off.....	17
5 Safety and Maintenance	18
5.1 Introduction	18
5.2 Reusability	18

5.3	Cleaning and Disinfecting	18
5.3.1	Cleaning	18
5.3.2	Daily cleaning	18
5.3.3	Weekly cleaning	19
5.3.4	Thorough cleaning every 3 months	19
5.3.5	Not in operation for 2 weeks or longer	20
5.4	Inspection and Maintenance	20
5.4.1	Daily Monitoring before and during the Examination Operation	20
5.4.2	Regular Monitoring	20
5.4.3	Maintenance	20
5.4.4	Warranty	20
5.4.5	Product Service Life	21
5.4.6	Further information	21
5.4.7	Disposal Notes	21
6	Power Supply	22
6.1	Electrical Connection	22
6.2	Protection Class	22
6.3	Power Consumption	22
7	Technical Data	23
7.1	Dimensions	24
7.2	Protection Type and Protection Class	24
7.3	Environmental Conditions	24
7.3.1	Environmental Conditions during Operation	24
7.3.2	Environmental Conditions for Shipping and Storage	24
8	Description of Symbols, Labels and Abbreviations	25
8.1	Symbols	25
8.2	Type Label	26
8.3	Labels	26
8.4	Positioning of the Signs and Labels	27
8.5	Abbreviations	28

**NOTE**

The information contained in this document conforms to the configuration of the equipment as of the date of manufacture. Revisions to the equipment subsequent to the date of manufacture will be addressed in service updates distributed to the PROTEC Technical Service Organization.

Revision Status

Revision	Date	Updated pages	Comment	Author
4.0	04/12/2018	all	Revision to 2010 housing, new pumps, new main drive, new document layout	
5.0	17/04/2019	20, 46,	Warning hot air new, max. power consumption in processing changed to 2,0.	
6.0	2021-05-25	all	V5.0 transferred to new layout (MDR)	MB
7.0	2025-02-19	Chap. 5.3.3	Securing latch blue deleted	ML
8.0	2025-07-16	All	First edition PROTEC X-ray Systems GmbH	ML

General Notes



WARNING!

In order to maintain the set and tested requirements of the 60601 series of standards, the ME system must not be modified during its actual operating life.

Mechanical and Electric Warning



WARNING!

All moving parts of the equipment should be operated with care. They must be inspected and maintained regularly and in accordance with the manufacturer's recommendations contained in the accompanying documents.

Only personnel authorized by PROTEC X-ray Systems GmbH may carry out maintenance and repair work. Touching live parts and connections can be fatal.

To the User



NOTE

The user of these accompanying documents is required to carefully read and consider the instructions, warnings and cautions contained therein before beginning operation.

Even if you have already operated similar equipment, the equipment described here may nevertheless have undergone changes in design, manufacture and functional sequence which have a considerable influence on operation.

Assembly and customer service work on the system described here must be carried out by the authorized and qualified personnel of PROTEC X-ray Systems GmbH. Assembly personnel and other persons who are not employees of the Technical Service Department of PROTEC X-ray Systems GmbH are requested to contact the local branch office of PROTEC X-ray Systems GmbH before starting any assembly or service work.

For assembly and service work, it is necessary to use the "Technical Description" of the Product and to observe the points contained therein.

Even if the product has been the subject of a hazard analysis and the design corresponds to the current state of the art, residual risks remain during clinical use. These are illustrated in the following instructions for use by application limits, warnings and precautions.

Assembly and customer service work on the X-ray film processor described here must be carried out by the authorized and qualified personnel of PROTEC X-ray Systems GmbH. Assembly personnel and other persons who are not employees of the Technical Service Department of PROTEC X-ray Systems GmbH are requested to contact the local branch office of PROTEC X-ray Systems GmbH before starting any assembly or service work.

**NOTE**

The use of the product with attachments or accessories not authorized by PROTEC or other non-approved components is not permitted.

**NOTE**

According to Regulation (EU) 2017/745 on medical devices, all serious incidents that have occurred in connection with the device must be reported to the manufacturer and the competent authority of the Member State in which the user and/or patient is resident.

1 Device Description

1.1 Introduction

These instructions for use describe the performance characteristics and operation required for efficient and effective handling of the automated X-ray film processor.

Before working with the automated X-ray film processor, the complete operating instructions must be read, in particular the safety instructions and the chapter Handling.



NOTE

The instructions for use are fully valid for **all** model variants of the automated X-ray film processor described.

1.2 Description

The automated X-ray film processor is a laboratory device used for automatic development of X-ray films in human medicine.

The device is equipped with a precise roller transport system that can process sheet films.

Automatic film acquisition starts as soon as a film is fed into the feeder.

The film materials are developed, fixed, watered and dried.

With the easy-to-use microprocessor control, processing conditions can be adjusted to suit a wide variety of films and chemicals.

The developer and fixing solutions are temperature controlled, circulated and automatically replenished.

This instructions for use provide important information on the installation, operation and maintenance of the unit. Please follow the instructions given carefully to ensure reliable operation of your automated X-ray film processor.

1.2.1 Versions

OPTIMAX, 220-240V, 50 Hz	1170-1-8000
OPTIMAX, 220-240V, 60 Hz	1170-2-8000
OPTIMAX, 220-240V, 60 Hz, for 110V operation	1170-9-8000
OPTIMAX Mammo, 220-240V, 50 Hz	1171-1-8000
OPTIMAX Mammo, 220-240V, 60 Hz	1171-2-8000
OPTIMAX Mammo, 220-240V, 60 Hz, for 110V operation	1171-9-8000

Optional accessories

The following optional accessories are available for the automated X-ray film processor:

- Base table 1267-0-0000

1.2.2 Installation



NOTE

The installation of the automated X-ray film processor must be performed by PROTEC Customer Service or a service authorized by it.

The automated X-ray film processor is intended for operation in a darkroom or in premises specially darkened for this purpose.

For detailed information, please refer to the installation instructions of the automated X-ray film processor.

Contact information of persons qualified by designation of the manufacturer to perform the installation is available upon request from:

PROTEC X-ray Systems GmbH

Germany

In den Dorfwiesen 14, 71720 Oberstenfeld

Telephone: +49 (0) 7062 – 92 55 0

Fax: +49 (0) 7062 – 92 55 60

E-Mail: protec@protec-med.com

Internet: www.protec-med.com

1.3 Performance Characteristics

- Dosage of replenishment based on integrated film surface measurement
- Anti-oxidation- and anti-crystallization programs
- Automatic tank filling during warm-up cycle
- Compatible with all common types of film and chemicals

1.4 Intended Use

The automated X-ray film processor is intended for automatic development of X-ray films in human medicine.

1.5 Clinical Benefit

The clinical benefit of using X-ray film processors is the development of X-ray films into two-dimensional X-ray images for creation or specification of findings as a basis for treatment decisions.

In analog X-ray diagnostics, X-ray film processing plays a very important role and makes an essential contribution to the application of this procedure. After the human body and the X-ray films have been irradiated, the X-ray film is generated with the aid of chemicals. Only after X-ray film generation, the X-ray films can be used for examination or diagnosis. Therefore, for the X-ray film processors, the general clinical benefit is valid for analog conventional X-ray examinations within the intended use.

1.6 Patient Target Group(s)

As X-ray film processors are not intended for use on patients, no intended patient group can be identified for them.

The intended patient group for a diagnostic X-ray imaging in human medicine includes all people for whom a justifying indication for a medical X-ray has been given by a physician with the necessary expertise in radiation protection.

There are no general or fundamental restrictions on the patient group regarding age, gender, origin and patient condition.

1.7 Medical Conditions to be diagnosed

Conventional X-ray images can be used to diagnose medical conditions.

A complete list of medical conditions to be diagnosed is not feasible, as the range of conventional radiographs is very diverse and may also vary in the course of medical-technical progress.

Examples for medical conditions to be diagnosed are:

- Bone fracture or bony injuries of the skeletal system or pathological changes of the bony tissue.
- Control of the correct set-up of the fracture.
- Luxation and bony ligament tears of the musculoskeletal system.
- Degenerative, inflammatory, traumatic and tumorous diseases and changes of the musculoskeletal system.
- Deformities and defective positions of the skeletal system.

- Thoracic and pulmonary symptomatology (thorax exposures).
- Sclerosis.
- Inflammatory and expansive processes of the mucous membrane, craniofacial bones and the expansion of the paranasal sinuses.
- Disease of the abdominal cavity (e.g., acute abdomen, abdominal overview radiograph, urethrogram, cystogram).

1.8 Indications and Contraindications

1.8.1 Indication

As X-ray film processors have no intended main effect in or at the human body, no indications can be shown for them.

The indication for diagnostic X-ray imaging in human medicine is always given when the patient derives a benefit from X-ray diagnostics that outweighs the radiation risk (justifying indication).

1.8.2 Contraindication

As X-ray film processors have no intended main effect in or at the human body, no contraindications can be shown for them.

There are no absolute contraindications for diagnostic X-ray imaging in human medicine. However, only medically indicated radiographs may be performed on individuals. For pregnant women and children, strong consideration must be given to whether a radiograph is necessary. If possible, it should be avoided.

1.9 Intended User Group

X-ray film processors are intended exclusively for use by professional users who are trained in the proper handling, use and operation as well as in the permitted conjunction with other medical products, objects and accessories.

Appropriate users can be, for example: X-ray technicians, X-ray assistants, medical technical X-ray assistants, surgeons, casualty surgeons, orthopaedists and other trained medical personnel.

1.10 Declaration of Conformity



This product complies with the requirements of Regulation (EU) 2017/745 of the European Parliament and of the Council of 5 April 2017 concerning medical devices, including all applicable corrigenda.

The declaration of conformity is available on request from:

PROTEC X-ray Systems GmbH

Germany

In den Dorfwiesen 14, 71720 Oberstenfeld

Telephone: +49 (0) 7062 – 92 55 0

Fax: +49 (0) 7062 – 92 55 60

E-Mail: protec@protec-med.com

Internet: www.protec-med.com

2 Safety Instructions

**NOTE**

Contains information that are relevant to the usage.

xxx

**CAUTION!**

Contains information that can cause damage to properties at non-conformity.

xxx

**WARNING!**

Contains information that can cause personal injuries at non-conformity.

xxx

Settings and calibrations not described in these operating instructions must be carried out based on the technical description of the device by PROTEC customer service or a service authorized by it.

**NOTE**

All instructions supplied with the automated X-ray film processor must be observed and any safety instructions contained therein must be carefully read and adhered to.

**NOTE**

After the initial installation, the commissioning must be logged with "Default function test".

**NOTE**

The X-ray film processors may only be commissioned if all safety measures for operator protection have been met and checked. These protective measures can include door contact, designated area, dosimeter, protective clothing, etc.

**CAUTION!**

The instructions for use contain all the information relevant to safety in order to generally put the X-ray film processor into operation. The device may only be operated by appropriately trained and trained personnel. In this context, operation is ensured by clear symbols on the control elements. All further information and instructions can be found on the supplied data carrier (USB, CD or DVD). This information applies in its entirety as an appendix to these instructions for use and must be observed.

**NOTE**

All control elements are described again in detail in these instructions for use.

2.1 General Safety Instructions

2.1.1 Requirements for Operation

To ensure safe operation of the automated X-ray film processor, it must be installed and operated in accordance with the information provided in this instruction for use, technical description and installation instructions.



NOTE

The automated X-ray film processor is suitable for all common types of film and chemicals that comply with the relevant specifications.
Developing and fixing solutions must be handled according to the manufacturer's instructions.
The chemical type is to be used according to the specifications of the film manufacturer.



WARNING!

The chemicals are corrosive in undiluted state. Therefore, avoid skin contact and wear suitable protective clothing such as goggles and gloves when working with the chemicals.



WARNING!

Inhalation of chemical vapors can be harmful and must be avoided. For this reason, sufficient ventilation must be ensured at the installation site.



WARNING!

If chemicals get into the eyes, rinse immediately with cold running water for approx. 15 min and consult a doctor immediately afterwards.

The environmental regulations concerning the deposit and disposal of used chemicals are to be inquired at the responsible water management offices and to be observed.

Before opening the device, it must be de-energized by disconnecting the power plug. Service and repair work may only be carried out by trained specialist personnel. Only original parts are to be used as spare parts.



WARNING!

**Protection class I device (according to EN 60601-1).
To avoid the risk of electric shock, this device may only be connected to a supply network with a protective earth conductor.**

2.1.2 Device Operation

In case of a malfunction, do not use the X-ray film processor anymore and notify PROTEC service department or a service company authorized by them.

2.1.2.1 Operating Type

This device is intended for continuous operation.

2.1.3 Operating Personnel

**NOTE**

Only trained and authorized personnel are allowed to work on the automated X-ray film processor.

**NOTE**

The operating personnel must be familiar with all warning signs attached to the X-ray film processor. They are used for your own safety and that of others and ensure proper operation.

2.1.4 Ventilation

**WARNING!**

Inhalation of chemical vapors can be harmful to health and must be avoided. For this reason, sufficient ventilation must be ensured at the installation site.

2.1.5 Explosion Protection

The automated X-ray film processor is not designated for use within areas with explosive hazards.

2.1.6 Interaction with Other Devices

Interactions with other devices are not known.

2.1.7 Electromagnetic Environment and influencing of Devices

Equipment affected by electromagnetic interference is not known.

The automated X-ray film processor is intended for use in an environment in professional healthcare facilities (e.g., clinics, surgery centers, physiology practices ...).

3 Control Elements and Displays

3.1 Main switch of the automated X-ray film processor

The automated X-ray film processor is switched on or off by the main switch.



3.2 Control Elements and Displays of the automated X-ray film processor

3.2.1 Standard Controls and Displays

LED displays:

Infeeding film
Wait with the next film until light goes off.

Power
When power is on the LED lights up.

Bath temperature
Flashes when temperature is not reached.

Temperature dial

Manual pumping

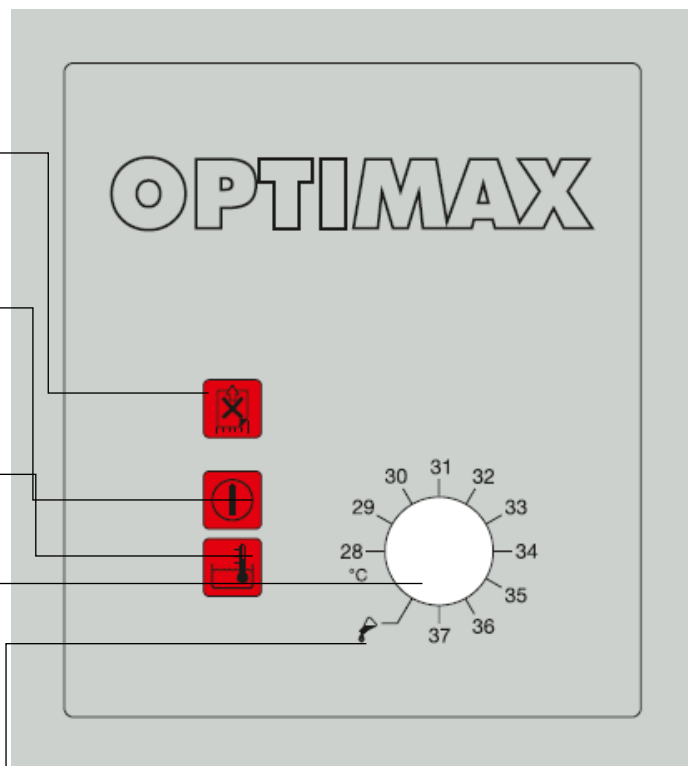

NOTE

Safety function stops film transportation when cover is removed.
Therefore, keep cover placed on the machine when processing films.

4 Handling



CAUTION!

During start-up and each time the automated X-ray film processor is refilled, check the function of the circulation pump and, if necessary, vent the circulation pumps. See installation instructions.



CAUTION!

Never operate the machine without liquid.



CAUTION!

Do not place any objects on the device.



NOTE

High or low room temperature can affect the functionality of the X-ray film processor. If the ambient temperature exceeds the set bath temperature, the image quality may deteriorate.



WARNING!

Hot air may escape when opening the lid of the film inlet!
Surface film feed tray (sheet) can be hot!

4.1 Operation of the automated X-ray film processor

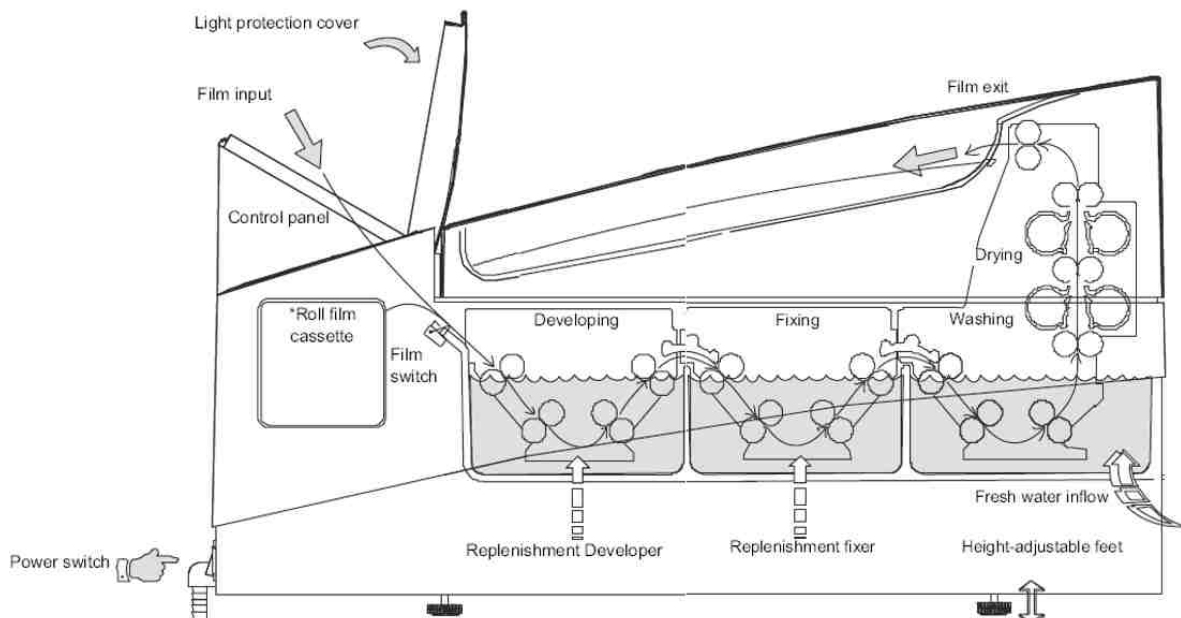

4.1.1 Before starting

- 1 Close water-drainage stop cock
- 2 Open water tap
- 3 Switch processor on

- 4 Check liquid level in replenishment and drainage collecting containers
- 5 Wait until the developer temperature is reached. If the temperature has not been reached, the bath temperature light is flashing
- 6 Run cleaning films through processor

4.1.2 Working procedure

- 7 Processing films:
Open light protection cover. Important: Put film first on left side of infeed tray and then feed in. During processing films please watch the display „Infeeding film“. If this is lit, wait until it goes off again and an acoustic signal can be heard, before inserting the next film.



NOTE

Put the film first on left side of infeed tray and then feed in.



CAUTION!

During processing films note the display „Infeeding film“

4.1.3 After work

- 8 Switch processor off
- 9 Close water tap
- 10 Open water-drainage stop cock and drain water out of the machine

4.1.4 Stand-by mode

When no film is being processed, the machine switches to Stand-by. The chemicals remain at a constant temperature. The film transport and water inflow activate at intervals to avoid crystallization of the chemicals on the transport rollers. Entry of the next film is possible at any time.

4.1.5 Switching on the device

The processor is switched on at the main switch on the front side. After switching on, the water tank will be filled up and a replenishment cycle will be carried out. The developer bath will be heated up. If the temperature has not been reached, the bath temperature light is flashing. When the machine is ready and the developer temperature has been reached, a long signal sound is heard.

4.1.6 Bath temperature

The processor heats up the chemicals automatically to the dial-set temperature. When this temperature is reached for the first time after switching on the machine, a long signal tone can be heard. This is also the case when the temperature is changed by the dial switch. If the difference between actual and dial-set temperature is more than 1°C, the bath temperature LED will flash. If a film has been fed in and the temperature is not reached, a warning sound will be heard.

4.1.7 Display “Infeeding film”

If films are fed into the processor without clearance one after another, then this may cause a film jam. The light „Infeeding film“ is on during in feeding a film. After the film has been fed in completely the light goes off. Additionally, an acoustic signal indicates that the next film can be fed in.

4.1.8 Manual pumping



NOTE

Both chemical pumps - fixer and developer - are driven parallel by only one motor and therefore they run always together.

The function „Manual pumping“ activates the replenishment pump. It pumps chemicals into the tanks in addition to automatic replenishment. To do so, turn the temperature dial to the position “Manual pumping“. This function is available only in standby mode (when there is no film in the unit). If the dial

is left in this position, the pumping function is stopped automatically after 20 minutes. To restart a cycle turn dial to a temperature and return to "Manual pumping".

Please note: Films cannot be processed when dial is set to "Manual pumping". Also, bath temperature is set automatically to 28 °C during "Manual pumping". After ending the manual pumping the temperature must be set again by turning the dial. It takes some time until the temperature is reached (look at the bath temperature display)

4.1.9 Anti-crystallization function

During the stand-by mode, the film transport, the dryer ventilation, the dryer heating and the water inflow are activated every 20 minutes for a period of 20 seconds. This prevents the build-up of crystals on the rollers.

4.1.10 Time replenishment

Also during the stand-by, the developer chemicals are subject to change which causes their deterioration. By means of the time replenishment, a replenishment cycle is activated after 60 minutes without replenishment. The pump runs for 15 seconds. With this function, the quality of the developer chemicals are maintained even when standing idle for long periods

4.1.11 Automatic replenishment

Depending on the processed amount of films the chemicals are replenished automatically. This is done by pumping chemicals from the replenishment containers. By means of the film detection switch at the film-infeed, the surface of the processed films is calculated and after approx. 0.25 m² a replenishment cycle is automatically activated for 40 seconds. The replenishment volume per cycle (with pump set at 100%) is 150 ml. The table below shows the replenishment volume in ml per m² film surface, dependent on the film width and the pump setting.

Replenishment Rate		
Film width	Setting of replenishment pump*	
	100% (85%)**	75% (62%)
35 cm	600ml/m ²	450ml/m ²
24 cm	870ml/m ²	650ml/m ²
18 cm	1150ml/m ²	875ml/m ²

*Setting at 50 Hz current resp. settings at 60 Hz current are in brackets

**Standard setting

4.2 Function of the automated X-ray film processor

4.2.1 Switching the automated X-ray film processor on and off

The automated X-ray film processor is switched on or off via the device switch.



5 Safety and Maintenance



WARNING!

Caution risk of electric shock!

Switch off the automated X-ray film processor before cleaning or disinfecting. This disconnects the automated X-ray film processor from the power source and eliminates the risk of electric shock.

5.1 Introduction

In this chapter you will find information about safety and maintenance necessary to ensure the correct and reliable operation of the device after installation.

5.2 Reusability

The automated X-ray film processor can be reused without any special reprocessing procedures.

5.3 Cleaning and Disinfecting



NOTE

Discoloration of the baths is normal due to the chemical properties and is not a defect.



CAUTION!

Do not use solvents containing alcohol when cleaning the machine.



WARNING!

Make sure that no liquid enters the inside of the housing during cleaning and disinfection to prevent electrical short circuits and/or corrosion.

Do not allow any liquids to run into the interior of the device or over the control panel. Liquids can damage the device.

5.3.1 Cleaning

Cleaning the automated X-ray film processor is very easy due to the very good quality surface coating. Generally, this is only done with a dry cloth.

Do not use any corrosive, dissolving or abrasive cleaning agents, which may damage the device surfaces or the coating.

Clean device surfaces and painted parts with a damp cloth and a mild to slightly alkaline cleaning solution (e.g., RBS® Neutral T) and wipe dry.

5.3.2 Daily cleaning

Before operation:

- Remove dirt from the film insert with a soft cloth
- Run 2 - 3 cleaning films to remove accumulated dirt and dust from the rollers
- Check the level in the regeneration tanks and refill solutions if necessary

After operation:

- After finishing work, the water must be drained from the machine. This reduces the growth of algae in the water bath.

5.3.3 Weekly cleaning



CAUTION!

Remove the water or dryer roller rack so that no water enters the air shaft.

The developer chemistry creates deposits in the machine. These deposits have a negative effect on the development process of the film material. The X-ray film processor must therefore be cleaned of these deposits at regular intervals.

Clean the roller rack every week, which takes only a few minutes.

- 1 Switch off the device and remove the cover
- 2 Open the locking mechanism of the roller racks: To do this, open the latches (red and beige) on the right side of the drive shaft.
- 3 Remove the roller packs and rinse thoroughly under warm running water and allow to drain. It is best to use a soft sponge (not a pot scrubber - this will scratch the rollers!) to remove the dirt from the rollers. The rollers can be moved by turning the drive shaft.
- 4 Dry the feed roller pair well (first roller pair of the developer).
- 5 Reinsert the roller sets: red = developer, blue = fixer, beige = washer/dryer. Make sure that they are inserted correctly and do not forget to lock the drive shaft.
- 6 Put the device cover back on and make sure that it is correctly attached.
- 7 Clean the outside of the unit with a damp cloth. Do not use harsh cleaners or solvents.

5.3.4 Thorough cleaning every 3 months

Depending on the film throughput, the machine must be thoroughly cleaned every 3 to 6 months by PROTEC customer service or a service authorized by PROTEC. Appropriate tank cleaners are available for the developer and water tanks; the fixer tank is cleaned with water only. When using chemical tank cleaners, follow the manufacturer's instructions.

Procedure:

- Switch off the device and empty the tanks by opening the shut-off valves. Caution: The device will not empty if it is switched on.
- Remove the device lid and wait until the tanks are completely empty, then close the stopcocks again. Fill the fixing tank with water. Prepare the cleaners for the developer and water tanks and fill them into the corresponding tanks.
- Pull the suction tubes out of the regeneration tanks and hang them in a bucket filled with water. Caution: Do not add any chemical cleaner!
- Put on the lid and switch on the unit.
- Start film transportation and keep running for 10 to 20 minutes. Place a film in the infeed so that it activates the film switch but will not be pulled into the processor. During the operation with water, the installed roller racks will be cleaned.



NOTE

After cleaning the tank, rinse the tanks thoroughly. Fill with fresh water twice and run the machine for 10 minutes each time. Empty the tanks again and close the shut-off valves.

- Take out the roller-racks and rinse them thoroughly with running water. Remove remaining dirt from the rollers by using a sponge and clean thoroughly. Doing this, the rollers can be turned by turning the drive shaft. Remove the sheet metal covers from the dryer rack and clean the rack with soap (dishwashing liquid). Reinstall the roller-racks in the machine.

- Refill the tanks with respective chemicals. Replace the suction pipes into the replenishment containers. In certain circumstances the circulation system must be ventilated (see installation instructions).
- For quality check, process test films.

5.3.5 Not in operation for 2 weeks or longer

If the X-ray film processor is not used for more than two weeks, then the chemicals must be drained from the tanks. If you do not want to perform tank cleaning right away, then fill the tanks with water.

5.4 Inspection and Maintenance



WARNING!

No maintenance or repair work may be carried out while the X-ray film processor is in use!

All maintenance and repair work may only be carried out by PROTEC trained or authorized personnel.



CAUTION!

Never operate the machine without liquid.

5.4.1 Daily Monitoring before and during the Examination Operation

n/a. See Chapter Cleaning.

5.4.2 Regular Monitoring

n/a. See Chapter Cleaning.

5.4.3 Maintenance

PROTEC Customer Service or a service authorized by it, must carry out the required maintenance every 3-6 months, depending on the film throughput and ensure the safe reliable functioning of the X-ray film processor.

The required specifications can be found in the corresponding Technical Description in Chapter 3 *Maintenance and Safety Inspection*.

In the event that the scheduled maintenance is not carried out, PROTEC X-ray Systems GmbH accepts no liability whatsoever for damage to the user and third parties if and to the extent that damage results from inadequate or non-performed maintenance.

Prior to test operation, the user must ensure that all safety devices listed in the instructions for use are functional and that the product is ready for operation.



NOTE

Wear parts must be replaced by original components.

5.4.4 Warranty



HINWEIS

The current warranty conditions can be found in your order papers or in the price list valid at the time of purchase.

Repairs and spare parts are also excluded in the event of improper operation.

Warranty work may only be carried out by trained specialist personnel.

5.4.5 Product Service Life

The X-ray film processor is designed for a service life of 7 years when used as specified and regularly maintained by PROTEC Customer Service or a service agent authorized by PROTEC. After reaching the product lifetime, further use is at your own risk.

5.4.6 Further information

Detailed information on the individual chapters and on safe operation, transport and storage can be found in the Technical Description and Installation Instructions of the X-ray film processor.

5.4.7 Disposal Notes

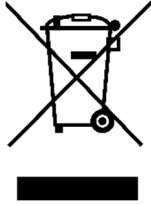

The automated X-ray film processor contains various plastics, oil and heavy metals. When disposing of replacement and spare parts as well as the entire system, the applicable rules and regulations must be observed. For this purpose, contact your contract partner or service company or commission a company specialized in the disposal of the respective components.

6 Power Supply

6.1 Electrical Connection

The electrical connection data of the device can be found on the type label.

Type 117x-1-x000	230 V ~ +/-10%, 8,8A, 50Hz
Type 117x-2-x000	230 V ~ +/-10%, 8,8A, 60Hz
Type 117x-9-x000	230 V ~ +/-10%, 7.1A, 60Hz for 110V operation

Device according to IEC 1010 (EN 61010, VDE 0411) overvoltage category II



WARNING!

To avoid the risk of electric shock, this device must only be connected to a supply network with a protective earth conductor.

6.2 Protection Class

IP 20

6.3 Power Consumption

Standby	0,12 kWh
Maximum in development mode at 230V/50Hz	2,0 kWh

7 Technical Data

Film transport	Continuous roller transport system
Film formats	In general: sheet films up to max. 35.8cm (14.1") width; Smallest film format 10x10 cm (4x4").
Processing capacity	129 films 24x30 cm (10x12 ") per hour (standard model, film fed in crosswise)
Processing time	Standard 90 s Mammography 135 s *Option 167 s
Linear speed	Standard 56 cm/min (22 in/min) Mammo 37 cm/min (14.5in/min) *Option 30 cm/min (11.8 in/min)
Developer time	Standard 25s Mammography 37s *Option 46s
Tank capacities:	Developer, Fixer and water tank, 5 litres each (1.3gal)
Circulation system	Developer and fixer are continuously circulated by a circulation pump
Replenishment	Automatic replenishment by film detection, in relation to film length
Developer temperature	Adjustable 28 - 37 °C (82.4 - 98.6 °F)
Fixer temperature	Adjusted to developer temperature by heat exchanger
Water connection	Permissible water pressure 2 - 10 bar (29 - 145 psi), permissible water temperature 5 - 30 °C (41 - 86 °F)
Water consumption	1.9 litres per minute (0.5 gal/min) when processing
Drain capacity	7 litres per minute (1.85 gal/min)
Noise level	Less than 58 dB(A)
Heat emission	Stand-by: 0.1 kJ/s Processing: 1.4 kJ/s
Pollution degree	2
Weight (processor)	Empty 35 kg (77 lbs) Filled 50 kg (110 lbs)
Dimensions (LxWxH)	77x59x42 (** 112) cm 30.3x23.2x16.5 (** 44.1)"
Floor space required	0.45 m ² (4.8 sqft)

* Depending on machine type and used gears processors have different speeds.

** Height incl. optional working table resp. base cabinet.

7.1 Dimensions

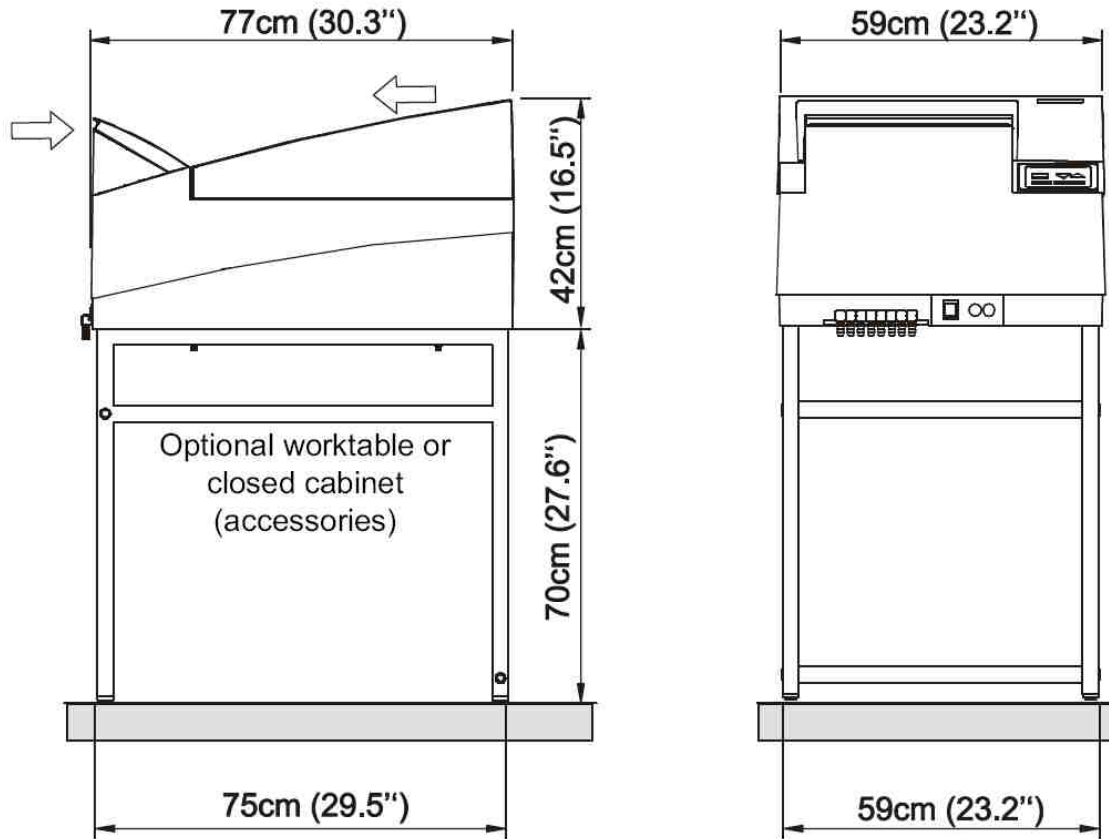

7.2 Protection Type and Protection Class

The X-ray film processor complies with protection class I.

7.3 Environmental Conditions

7.3.1 Environmental Conditions during Operation



















Usage	Only indoor (darkroom)
Surrounding temperature	18 - 40 °C (51,6 - 104 °F), ventilated room, room temperature must be lower than set bath temperature. If the ambient temperature exceeds the set bath temperature, the image quality may deteriorate.
Relative humidity	Humidity less than 80% up to 31°C (80°F), decreasing linearly to 50% at 40°C (104°F).
Air pressure	Altitude above sea level less than 2000m (6666 feet).







7.3.2 Environmental Conditions for Shipping and Storage

Surrounding temperature	- 10°C to +70°C
Relative humidity	10% to 95% (non-condensing)
Air pressure	500 hPa to 1060 hPa

8 Description of Symbols, Labels and Abbreviations

8.1 Symbols

	Atmospheric pressure limit
	Temperature limit
	Humidity limit
	Keep dry
	Fragile, handle with care
	This way up
	Attention, observe accompanying documents
	CE-marking
	Manufacturer
	Medical Device
	Order reference
	Serial number
	Unique Device Identification
	Production date
 www.protec-med.com/download	This symbol indicates the need to consult the operating instructions. This is provided in an electronic format (eIFU) on our website.
	Disposal instructions; WEEE , Waste of Electrical and Electronic Equipment
	Earth ground
	Electrical voltage warning
	Hot surface warning

	Symbol bath temperature
	Symbol cycle time
	Symbol in operation
	Replenishment
	Overflow
	Drain

8.2 Type Label

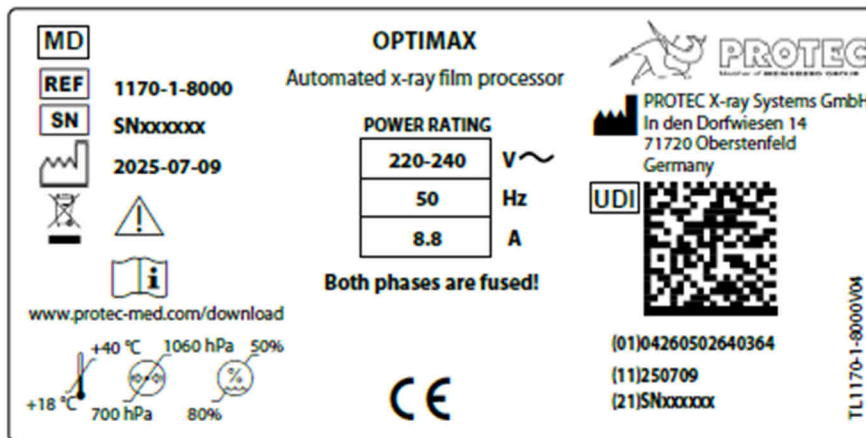

8.3 Labels

Company label

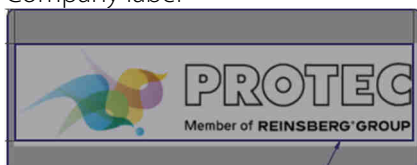

Operating foil

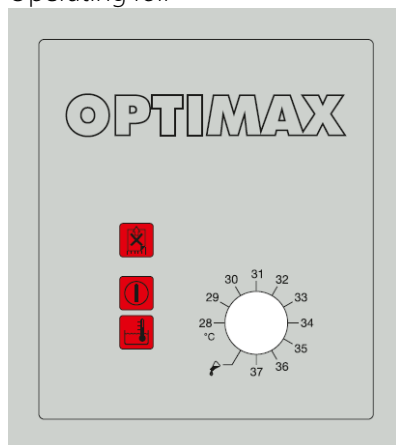

Designation hose connections

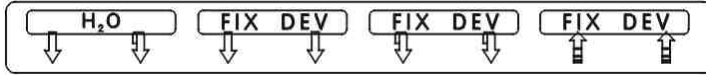

Description of the fuse

2x T / sb
10A 250V

Label water pressure

Wasseranschluß:	Zulässiger Wasserdruck 2-10 bar
Water connection:	Permissible water pressure 2-10 bar
Arrivée d'eau:	Pression nécessaire de 2 à 10 bars
Conexión de agua:	Presión admisible del agua: 2-10 bares
Connessione acqua:	Pressione ammissibile dell' acqua: 2-10

Label on the floor plate



Pull plug

8.4 Positioning of the Signs and Labels

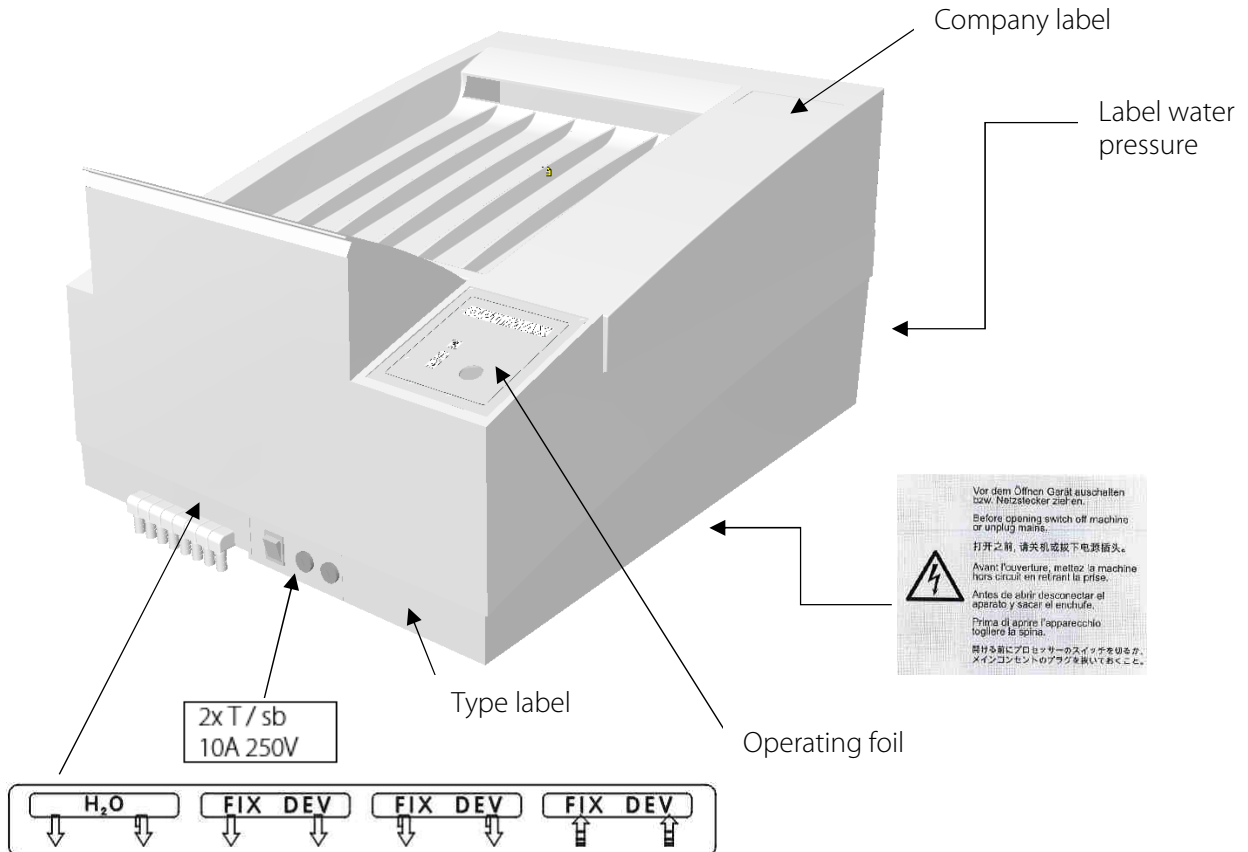

8.5 Abbreviations

mm	Millimetre
cm	Centimetre
Lb	Pound
kg	Kilogram
°C	Degree Celsius
hPa	Hectopascal
DIN	German Industry Standard
EN	European Standard
CE	CE marking
Hz	Hertz
ED	Duty Cycle
A	Ampere
SN	Serial number