

PROGNOST C

Diagnostic X-ray system mechanics

Model/ID: 7073-9-000X
Basic UDI-DI: 426050264X013ZJ

Instructions for use

Ident. No. 5073-0-0002



CE



NOTE

All sheets of this document contain proprietary and confidential information of PROTEC X-ray Systems GmbH and is intended for exclusive use by current PROTEC X-ray Systems GmbH customers. Copying, disclosure to others or other use is prohibited without the express written consent of PROTEC's law department. Knowledge of violations of these regulations must be reported immediately to PROTEC X-ray Systems GmbH.

© 2025 PROTEC X-ray Systems GmbH, Oberstenfeld

Comments and questions about the documentation, please contact:

PROTEC X-ray Systems GmbH

In den Dorfwiesen 14 | 71720 Oberstenfeld
Germany

Phone: (+ 49) 7062 – 92 55 0

Fax: (+ 49) 7062 – 92 55 60

E-Mail: protec@protec-med.com

Internet: www.protec-med.com

Table of contents

	Page
Table of contents	3
Revision Status	5
General Notes	6
Mechanical and Electric Warning	6
To the User	6
1 Device Description	7
1.1 Introduction	7
1.2 Description.....	7
1.2.1 Versions	7
1.2.2 Hardware and Network System Requirements	7
1.2.3 Installation	8
1.2.3.1 Floor loading capacity.....	8
1.3 Performance Characteristics	8
1.3.1 X-ray System Table	8
1.3.2 Floor-guided tube column stand.....	8
1.3.3 Vertical Bucky Wall Stand	9
1.4 Intended Use	9
1.5 Clinical Benefit	9
1.6 Patient Target Group(s).....	9
1.7 Medical Conditions to be diagnosed.....	9
1.8 Indications and Contraindications	9
1.9 Intended User Group.....	9
1.10 Declaration of Conformity.....	10
2 Safety Instructions	11
2.1 General Safety Instructions.....	12
2.1.1 Requirements for operation	12
2.1.2 Device Operation	12
2.1.2.1 Operating Type	12
2.1.3 Operating Personnel	12
2.1.4 Crushing and Collision Hazard.....	12
2.1.5 Explosion Protection	12
2.1.6 Interaction with Other Devices.....	12
2.1.7 Electromagnetic Environment and Influencing of Devices.....	13
3 Control Elements and Displays	14
3.1 Main Switch of the PROGNOST C	14
3.2 Emergency Stop Switch of the PROGNOST C.....	14
3.3 Floor-guided tube column stand	14
3.4 X-ray system table	15
3.5 Vertical Bucky Wall Stand.....	15
4 Handling	16
4.1 Requirements before and during Operation.....	16
4.2 Operation of the PROGNOST C	16
4.2.1 Releasing the tabletop brake and positioning the tabletop	16
4.2.2 Positioning the image receptor from the wall stand.....	16
4.2.3 Exposures with mechanics for diagnostic X-ray systems.....	16
4.2.3.1 Positioning/descending of the patient on/from the tabletop	16
4.2.3.2 Setting the X-ray unit on the centre of the Bucky, Grid Entity	16
4.2.3.3 Inserting a cassette into the cassette tray.....	16
4.2.3.4 Adjustment of the focus-film distance (SID).....	17
4.2.3.5 Adjusting the light-/beam field.....	17
4.2.3.6 Exposure preparation / Exposure releasing.....	17
4.2.3.7 Exposure with cassette on the tabletop.....	17

4.2.4	Operation at the wall stand	17
4.2.4.1	Adjustment of the X-ray unit to the centre of a cassette or Bucky/Grid Entity of an X-ray system wall stand (vertical centre beam)	17
4.2.4.2	Adjustment of image-receptor distance (SID)	17
4.2.4.3	Adjustment of the light-/ radiation field.....	17
4.2.4.4	Exposure preparation/ Exposure release.....	18
4.3	Function of the PROGNOST C.....	18
4.3.1	Switching the PRS 500 C on and off.....	18
5	Safety and Maintenance.....	19
5.1	Introduction	19
5.2	Reusability	19
5.3	Cleaning and Disinfection.....	19
5.3.1	Cleaning.....	19
5.3.2	Disinfection.....	19
5.4	Inspection and Maintenance.....	20
5.4.1	Daily Monitoring before and during Examination Operation	20
5.4.2	Regular Monitoring.....	20
5.4.2.1	Quality control by the user.....	20
5.4.3	Maintenance	20
5.4.4	Warranty.....	21
5.4.5	Product Service Life	21
5.4.6	Further Information	21
5.4.7	Applied Parts and Parts Considered as Applied Parts.....	21
5.4.8	Disposal Notes	21
6	Power Supply	22
6.1	Electromagnetic Compatibility (EMC) according to EN 60601-1-2	22
6.1.1	Guidelines and Manufacturers Declaration – Electromagnetic Interference.....	22
7	Technical Data.....	25
7.1	Dimensions.....	25
7.1.1	Patient positioning table	27
7.1.2	Bucky unit.....	27
7.1.3	X-ray stem tube support, floor stand.....	27
7.1.4	Vertical X-ray system image receptor stand	27
7.2	Attenuation Equivalent.....	28
7.2.1	Protection Type and Protection Class	28
7.3	Environmental Conditions	28
7.3.1	Environmental Conditions during Operation.....	28
7.3.2	Environmental Conditions for Shipping and Storage	28
8	Description of Symbols, Labels and Abbreviations.....	29
8.1	Symbols	29
8.2	Type Label	30
8.3	Labels	30
8.4	Positions of the Signs and Labels.....	31
8.5	Abbreviations.....	31

**NOTE**

The information contained in this document conforms to the configuration of the equipment as of the date of manufacture. Revisions to the equipment subsequent to the date of manufacture will be addressed in service updates distributed to the PROTEC Technical Service Organization.

Revision Status

Revision	Date	Updated pages	Comments	Author
1.0	2020-11-26	all	Original issue	
2.0	2021-02-25	Front Page, 7, 11, 14, 15, 18, 23, 27	Product picture, Warning mattress, Compatible components, mattress at characteristic table added, symbols and labels, cleaning, mattress added to technical data table	
3.0	2021-03-11	7, 8, 18, 19, 20, 21, 23, 24, 25, 26, 27	X-ray mattress description, compatible components, note X-ray mattress at characteristic table, cleaning, disinfection, lifetime, applied parts, symbols and labels, chapter power supply connection, X-ray mattress changed at technical data table, note attenuation equivalent	
4.0	2021-05-26	all	V3.0 transferred to new layout (MDR)	MB
5.0	2021-11-24	8, 10, 15-19, 21, 26-32	X-ray mattress removed, front page changed, Chap. 1 product description revised, chap. 3 control elements & device displays revised, chap. 4 Handling revised, chap. 5 safety maintenance revised, chap. 7 technical data revised, chap. 8 description of symbols & labels revised	MB
6.0	2022-01-07	7, 9, 15, 21	Chap. 1.2.1 Versions revised Chap. 1.4 Intended use revised Chap. 3 Control elements & device displays revised Chap. 5.4.7 Mattress added	MB
6.1	2022-03-29	26	7.1.4 Vertical X-ray system image receptor stand value revised	MB
7.0	2023-06-23	28, 30	Value temperature updated, type label updated	MB
8.0	2024-04-12	Chap. 4.2.1	Positioning of the tabletop optimised	DP
9.0	2024-07-16	All	First edition PROTEC X-ray Systems GmbH	ML

General Notes

**WARNING!**

In order to maintain the set and tested requirements of the 60601 series of standards, the ME system must not be modified during its actual operating life.

Mechanical and Electric Warning

**WARNING!**

All of the movable assemblies and parts of this equipment should be operated with care and routinely inspected in accordance with the manufacturer's recommendations contained in the equipment accompanying documents. Maintenance and service is only to be performed by customers authorized by PROTEC X-ray Systems GmbH.

Live electrical terminals are deadly.

Do not remove flexible high-tension cables from X-ray tube cover or high-tension generator and/or access covers from X-ray generator.

For all components of the equipment protective earthing means must be provided in compliance with the national regulations.

Failure to comply with the foregoing may result in serious or fatal bodily injuries to the operator or those in the area.

To the User

**NOTE**

The user of these accompanying documents is required to carefully read through and carefully consider the instructions, warnings and cautions contained therein before starting operation.

Even if you have already operated similar systems, changes in the design, production and functional routine of the system described here may have been made, which have a significant influence on the operation.

Assembly and service works on the system described here must be carried out by authorised and qualified personnel from PROTEC X-ray Systems GmbH. Assembly personnel and other persons who are not employees of the technical service department of PROTEC X-ray Systems GmbH are requested to contact the local branch of PROTEC X-ray Systems GmbH before assembly or service work is started. For assembly and service works, it is necessary to use the "Technical Description" of the product and to observe the points it contains.

**NOTE**

The use of the product with add-on or accessory parts not authorized by PROTEC or other unapproved components is not permitted.

**NOTE**

According to Regulation (EU) 2017/745 of medical devices, all serious incidents related to the device must be reported to the manufacturer and the responsible authority of the Member State where the user and/or the patient is established.

1 Device Description

1.1 Introduction

The instructions for use describe the performance characteristics and operation required for efficient and effective use of the PROGNOST C.

Before you work with the PROGNOST C, the complete instructions for use must be read, especially the Safety Instructions and the chapter Handling.

1.2 Description

The mechanics for diagnostic X-ray systems PROGNOST C is constituted of a stationary X-ray system table with floating tabletop, a floor-guided tube column stand and a vertical Bucky wall stand (without X-ray components).

The floating tabletop can be locked in a longitudinal and transverse direction by using an electromagnetic brake. The brake is controlled by a light barrier.

The table is prepared for the installation of a longitudinally sliding Bucky or Grid entity, an anti-scatter grid and a measuring chamber intended for use with an automatic exposure control.

The tube column stand is guided by one rail, which is fixed on the ground behind the table. All movements of the column stand are smooth and locked by electromagnetic brakes. The weight-balanced support arm is prepared for the installation of an X-ray tube assembly (X-ray tube, collimator and control panel with integrated controls).

1.2.1 Versions

PROGNOST C	7073-9-0001 Wall stand left
PROGNOST C	7073-9-0002 Wall stand right

Optional Components

- Collimator
- X-ray tube assembly
- X-ray generator VENUS-series
- Measuring chamber
- Dose area product meter system
- Anti-scatter grid
- Different direct X-ray-systems (RAPIXX-series)
(consisting of DR-detector, Interface Box, and Software)

Optional Accessories

- Patient extending handle
- Mattress 225 cm x 70 cm x 2 cm

Accessories that can influence the EMC conditions

- Network cable ((take note of the max. cable length in the system documents)
- Wi-Fi router (only use devices approved by PROTEC)

1.2.2 Hardware and Network System Requirements

As a stand-alone product, the PROGNOST C has no hardware or network connection and therefore no hardware or network requirements.

1.2.3 Installation



NOTE

The installation of the PROGNOST C must be performed by PROTEC service department or a service company authorized by them.

For more information, please see separate Installation manual of the PROGNOST C.

Contact information of persons qualified to perform installations are available upon request at:

PROTEC X-ray Systems GmbH

In den Dorfwiesen 14 | 71720 Oberstenfeld
Germany

Phone: (+ 49) 7062 – 92 55 0

Fax: (+ 49) 7062 – 92 55 60

E-Mail: protec@protec-med.com

Internet: www.protec-med.com

1.2.3.1 Floor loading capacity



NOTE

The PROGNOST C is primarily made of metal pieces. This has a main role in the weight of the device.

The X-ray system PROGNOST C has a weight of **545kg**.

Every technician is obliged to check the ground loading capacity. Also raised floors and hollow floors must be taken into account.

1.3 Performance Characteristics

1.3.1 X-ray System Table

- Floating tabletop
- Tabletop colour white
- Electromagnetic tabletop brake for effortless patient positioning
- A low optimized distance between the tabletop surface and the film (detector) surface
- Large adjustment range of the tabletop for position of the patient
- Reliable construction
- Prepared for the installation of a Bucky with anti-scatter grid and 3-field measuring chamber intended for the use with automatic exposure control
- Useable for variable cassette/detector sizes. Formats from 13 cm x 18 cm (5" x 7") to 43 cm x 43 cm (17" x 17"), depending on analogue or digital use.

1.3.2 Floor-guided tube column stand

- Ceiling-free column stand intended for use within rooms with a ceiling height of at least 2.20 meters
- Wide range of application
- Small wall distance allows good space utilization
- Control elements within the command arm are well placed and easy to activate
- Reproducible positioning of the X-ray tube assembly (positions resulting from rotation around the axis of the carrying arm) through angle indicator
- Vertical range of travel of the focus height from 40.0 cm up to 176.5 cm during horizontal beam projection

- Electromagnetic brakes for the longitudinal movement of the column stand, the vertical movements of the carrying arm, the rotational movements of the X-ray tube assembly around the axis of the carrying arm +/-135°.
- Integrated safety connector for automatically centring the X-ray tube assembly and the Bucky in the longitudinal direction.

1.3.3 Vertical Bucky Wall Stand

- Space saving with minimal footprint
- Wall – floor mounting of floor mounting
- cassette loading from the right or left side (specified at installation)
- Useable for variable cassette/detector sizes. Formats from 13 cm x 18 cm (5" x 7") to 43 cm x 43 cm (17" x 17"), depending on analogue or digital use.

1.4 Intended Use

The X-ray system mechanics PROGNOST C is designated as a component to be used for the assembly of a diagnostic X-Ray system for various routine applications in planar X-ray imaging in human medicine.

1.5 Clinical Benefit

Considered in isolation, no clinical benefit can be shown for X-ray system mechanics.

As components of diagnostic X-ray systems in human medicine, they contribute to the clinical benefit of X-ray systems, which consists of the generation of conventional two-dimensional X-ray images for creation or specification of findings as a basis for treatment decisions.

1.6 Patient Target Group(s)

The intended patient group includes all people for whom a justifying indication for a medical X-ray has been given by a physician with the necessary expertise in radiation protection.

There are no general or fundamental restrictions on the patient group regarding age, gender, origin and patient condition.

1.7 Medical Conditions to be diagnosed

As standalone products, X-ray system mechanics, have no function to diagnose, treat and/or monitor medical conditions.

1.8 Indications and Contraindications

As standalone products, X-ray system mechanics have no intended main effect in or at the human body. Therefore, considered in isolation, no indications and contraindications can be shown for them.

1.9 Intended User Group

As a component of a diagnostic X-ray system, PROGNOST C is intended exclusively for use by professional users who are trained in the operation of diagnostic X-ray systems in accordance with the respective national regulations and who are familiar with the proper handling, use and operation and also have been instructed in the permitted conjunction with other medical products, objects and accessories.

Appropriate users can be, for example: X-ray technicians, X-ray assistants, medical technical X-ray assistants, surgeons, casualty surgeons, orthopaedists and other trained medical personnel.

1.10 Declaration of Conformity



This product complies with the requirements of Regulation (EU) 2017/745 of the European Parliament and of the Council of 5 April 2017 concerning medical devices, including all applicable corrigenda.

The declaration of conformity is available upon request from PROTEC:

PROTEC X-ray Systems GmbH

In den Dorfwiesen 14 | 71720 Oberstenfeld
Germany

Phone: (+ 49) 7062 – 92 55 0

Fax: (+ 49) 7062 – 92 55 60

E-Mail: protec@protec-med.com

Internet: www.protec-med.com

2 Safety Instructions



NOTE

Contains information that must be observed during operation.

xxx



CAUTION!

Contains information which, if not observed, can cause property damage.

xxx



WARNING!

Contains information which, if not followed, can cause personal injury.

xxx



WARNING!

Warning of radioactive substances or ionizing radiation. Contains information which, if not observed, can cause personal injury.

xxx

Settings and calibrations that are not described in these instructions for use must be carried out using the technical description of the device by PROTEC service department or a service company authorized by them.



NOTE

All instructions supplied with the PROGNOST C must be observed and the safety instructions contained therein must be carefully read and adhered to.



NOTE

After the initial installation, the commissioning must be recorded with the PROTEC acceptance protocol FB-04-07A4.



NOTE

The PROGNOST C may only be commissioned if all safety measures for operator protection have been met and checked. These protective measures can include door contact, designated area, dosimeter, protective clothing, etc.



CAUTION!

The instructions for use contain all the information relevant to safety in order to generally put the PROGNOST C into operation. The device may only be operated by appropriately trained and trained personnel. In this context, operation is ensured by clear symbols on the control elements. All further information and instructions can be found on the supplied data carrier (USB, CD or DVD). This information applies in its entirety as an appendix to these instructions for use and must be observed.



NOTE

All control elements are described again in detail in these operating instructions.

2.1 General Safety Instructions

2.1.1 Requirements for operation



WARNING!

The PROGNOST C is a protection class I device (according to EN 60601-1). To avoid the risk of an electric shock, this device may only be connected to a supply network with a protective earthing conductor. The power supply for the PROGNOST C of the X-ray system is exclusively made by direct connection to the X-ray generator or the Power Box and is permanently connected there. The X-ray generator or the Power Box must have at least 2 connections for 230V 50/60Hz. The X-ray generator of the X-ray system is connected to the supply network (see technical description of the X-ray generator). To reduce the risk of electric shock, the system must be connected to a supply network with protective earthing. The system does not have an on/off switch. It is switched on or off directly by switching on the X-ray generator or by the switch on the Power Box. In order to separate any electrical voltage from the X-ray system, the connected X-ray generator or the Power Box must be switched off.

2.1.2 Device Operation

In case of a malfunction, do not use the PROGNOST C anymore and notify PROTEC service department or a service company authorized by them.

2.1.2.1 Operating Type

The PROGNOST C is not intended for continuous operation.

2.1.3 Operating Personnel



NOTE

Only trained and authorized personnel are allowed to work on the PROGNOST C.



NOTE

The operating personnel must be familiar with all warning signs attached to the PROGNOST C. They are used for your own safety and that of others and ensure proper operation.

2.1.4 Crushing and Collision Hazard



WARNING!

It must be ensured that when operating the moving parts of PROGNOST C, no persons or objects are in the obvious danger area of the device. If not observed, it can result in personal injury or damage to the PROGNOST C or other objects.

2.1.5 Explosion Protection

These PROGNOST C is not designated for use within areas with explosive hazards.

2.1.6 Interaction with Other Devices

Interactions with other devices are not known.

2.1.7 Electromagnetic Environment and Influencing of Devices

**CAUTION!**

The use of other accessories, other converters and other cables than those specified by PROTEC or provided in the documentation of the component manufacturer can result in increased electromagnetic interference or reduced electromagnetic immunity of the device and lead to defective operation.

**CAUTION!**

The use of the PROGNOST C immediately next to other devices or with other devices in a stacked form should be avoided, as this could result in defective operation. If use in the manner described above is nevertheless necessary, the PROGNOST C and the other devices should be observed to ensure that they are working properly.

**NOTE**

The properties of this device, determined by emissions, allow its use in industrial areas and in hospitals (CISPR 11, class A). When used in residential areas (for which class B is usually required by CISPR 11), this device may not provide adequate protection for radio services. The user may need to take remedial measures such as relocating or realigning the device.

The PROGNOST C is intended for use in an environment in professional health care facilities (e.g., clinics, surgery centres, physiology practices ...).

3 Control Elements and Displays

3.1 Main Switch of the PROGNOST C

The PROGNOST C is switched on and off via a button (on the backside of the X-ray system table).



3.2 Emergency Stop Switch of the PROGNOST C

The PROGNOST C does not have an emergency stop switch.

3.3 Floor-guided tube column stand

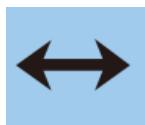
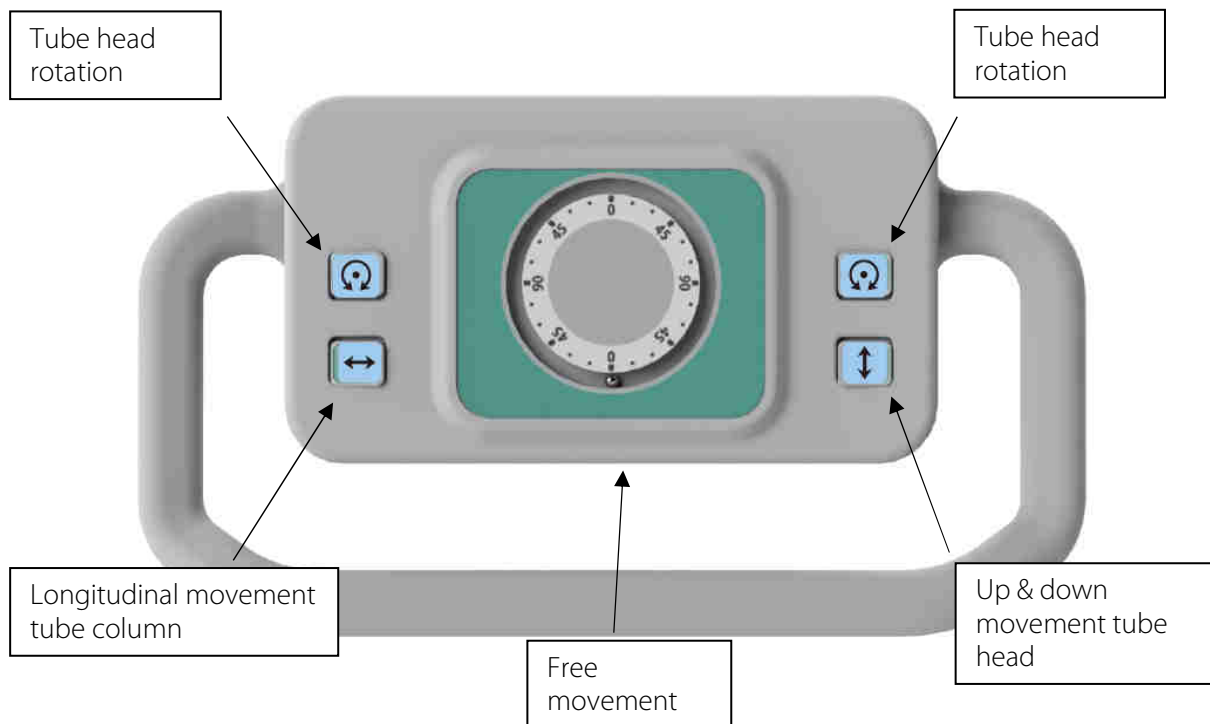

Longitudinal movement tube column

Brake for the longitudinal/horizontal movement of the tube column

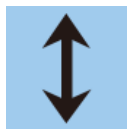

Tube head up/down

Brake for the height positioning /vertical movement of the tube head



Tube Rotation

Brake for the tube head rotation around the carrying axis

Free movement (sensor beneath the tube head)

Permits the horizontal movement of the tube column and vertical movement of the tube head

3.4 X-ray system table

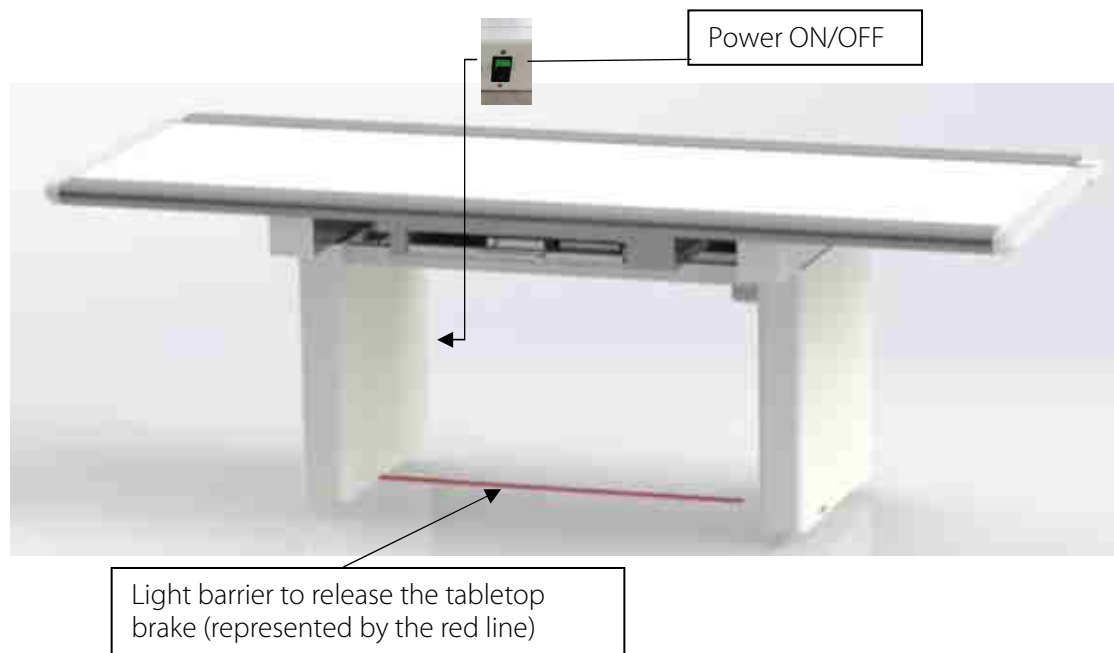

CAUTION!

By activating the light barrier, the electromagnetic tabletop brakes are supplied with power that they switch off and the tabletop can be moved. It must be ensured that no objects are continuously laying in the light barrier and permanently trigger it, otherwise the brakes are supplied with continuous current and could get damaged.

3.5 Vertical Bucky Wall Stand

Brake for the vertical movement of the wall stand Bucky.



4 Handling

4.1 Requirements before and during Operation

It must be ensured that the surfaces in contact with patients are disinfected before the X-ray examination of each patient (see chapter 5.3.2).

4.2 Operation of the PROGNOST C

4.2.1 Releasing the tabletop brake and positioning the tabletop



NOTE

Prior to patient positioning, the X-ray unit must be brought into the required exposure position.



WARNING!

The tabletop may only be locked when the tabletop is in the rest position, not while it is being moved.

1. Release the tabletop brakes by interrupting the light barrier with your foot.
2. Move the floating tabletop to the desired position by hand while keeping the light barrier interrupted.
3. When the tabletop is in the rest position, release the light barrier and the tabletop will be locked again by the brakes.

4.2.2 Positioning the image receptor from the wall stand

By pressing the release button on the wall stand, the brakes for the grid device are released, the grid device can be moved by hand.

4.2.3 Exposures with mechanics for diagnostic X-ray systems

4.2.3.1 Positioning/descending of the patient on/from the tabletop

- Move the tabletop to a position to make it easy for the patient to climb onto/from the table surface.
- The patient should position himself in the middle of the tabletop and remain in this position.

4.2.3.2 Setting the X-ray unit on the centre of the Bucky, Grid Entity

- By pressing the button “longitudinal movement tube column” (see figure operating unit), release the brake for the longitudinal movement.
- Grab both handles on both sides of the command arm.
- Move the X-ray tube assembly in the longitudinal direction along the radiographic X-ray table until the Bucky/Grid Entity snaps into the safety coupling.

4.2.3.3 Inserting a cassette into the cassette tray

- A film cassette may be placed into the cassette tray, after the X-ray tube assembly is positioned.
- Pull out the cassette tray by its handle from the Bucky/Grid Entity unit until it hits the forward stop.
- Rotate the latch for opening/closing the clamping device, for lateral fixation of the cassette, counter clockwise to unlock it.
- Open the cassette clamps far enough to insert a cassette of the desired size.
- Insert the cassette, aligning its centreline with the notch on the clamp, or after engaging the cassette positioner in the notch corresponding to the cassette size (13 cm, 18 cm, 24 cm, 30 cm, 35 cm, 40 cm or 43 cm), push the cassette toward the cassette positioner.
- Push the cassette clamps against the cassette and rotate the latch into the locked position.
- Push the cassette tray fully into the Bucky/Grid Entity.

4.2.3.4 Adjustment of the focus-film distance (SID)

- Set the X-ray unit with a tape measure at the collimator or the display on the tube head to the desired focus-film distance (SID).
- Press the button "Tube head up/down" to release the brake for the height adjustment of the X-ray tube assembly.

4.2.3.5 Adjusting the light-/beam field

- Switch on the collimator light to check the opening of the collimator shutters to the used cassette.
- Use the adjusting knobs to set the collimator shutters to the size of the cassette being used. The setting is made on the scale for the corresponding focus-film distance (SID). This limits the light-/beam field to the cassette size used.

4.2.3.6 Exposure preparation / Exposure releasing

- Select the application device (X-ray system table with Bucky, Grid Entity) on the X-ray generator control panel
- Set the desired organ program or exposure data and initiate the exposure by pressing the exposure preparation /release controls.

4.2.3.7 Exposure with cassette on the tabletop

- Place a cassette to the desired position on the tabletop.
- Move the X-ray tube to the desired SID position.
- Turn on the collimator light and view the opening of the collimator shutters to the cassette size.
- Adjust the light field with the adjusting knobs onto the size of the used cassette, that the radiation field will be limited to the size of the cassette.
- Select the application device (X-ray system table with Bucky, Grid Entity) on the X-ray generator control panel
- Set the desired organ program or exposure data and initiate the exposure by pressing the exposure preparation /release controls.

4.2.4 Operation at the wall stand

4.2.4.1 Adjustment of the X-ray unit to the centre of a cassette or Bucky/Grid Entity of an X-ray system wall stand (vertical centre beam)

- By pressing button "tube head rotation" the brake for the rotation X-ray tube assembly will be released.
- Swing the X-ray unit to the X-ray system wall stand.
- Set the Bucky, Grid Entity on the wall stand to the size of the patient (see figure vertical Bucky wall stand).

4.2.4.2 Adjustment of image-receptor distance (SID)

- Release brake of the tube column by pressing button "Longitudinal movement tube column" and adjust the source to image-receptor distance (SID) which will be used for the exposure. Notice the focus area of the scanning unit, Bucky and Grid Entity. Those settings must be done with the measuring tape inside the collimator or with the markings on the upper guidance of the column.

4.2.4.3 Adjustment of the light-/ radiation field

- By using the button "Up/down movement tube head" the brake for adjusting the height will be released.
- Set the collimator to the requested height and align it to the Bucky by using the light-beam localizer.
- Release Button "Up/down movement tube head" to activate the height-adjustable brake for the X-ray tube head assembly.
- Activate the light-beam of the collimator to check the opening of the shutters to the used cassette.
- Adjust the shutters with the adjusting knobs of the collimator to the size of the used cassette. The settings will be done on the scale to the according cassette source to image-receptor distance (SID). So, the light-/ radiation field is limited to the according cassette.

4.2.4.4 Exposure preparation/ Exposure release

- Select the used device on the console of the generator (vertical wall stand).
- Select the requested organ program or the requested exposure details and start the exposure by using the control element for exposure preparation/ release.

4.3 Function of the PROGNOST C

4.3.1 Switching the PRS 500 C on and off

The PROGNOST C starts with applying of a power supply and activation of the main switch at the backside of the X-ray system table (see chapter 3.1). The PROGNOST C is switched off by deactivating the main switch on the X-ray system table and removing the power supply.

5 Safety and Maintenance



WARNING!

Caution, risk of electric shock!

Turn off the PROGNOST C before cleaning or disinfecting. This disconnects the PROGNOST C from the power source and avoids the risk of electric shock.

5.1 Introduction

In this chapter you will find information about safety and maintenance that are necessary to ensure the correct and reliable function of the device after installation.

5.2 Reusability

The PROGNOST C can be reused without any special preparation procedures.

However, it must be ensured that the surfaces in contact with patients are disinfected before the X-ray examination of each patient (see also chapter 4.1).

The PROGNOST C must no longer be used with patients if it shows signs of wear (e.g., metal abrasion, wear of insulations) or dangerous technical defects (e.g., torn cable, bent parts) or if the resulting image quality (e.g., artifacts in the image) is insufficient.

In this case, please contact PROTEC service department or a service company authorized by them immediately.

5.3 Cleaning and Disinfection



NOTE

Caution!

Possible material changes!



WARNING!

Make sure that no liquid enters the interior of the housing during cleaning and disinfection in order to prevent electrical short circuits and/or corrosion.

5.3.1 Cleaning

The cleaning of the PROGNOST C is very easy due to the very good quality surface coating. This is usually only done with a dry cloth.

Do not use corrosive, dissolving or abrasive cleaning agents, which could damage the device surfaces or the coating.

Clean the device surfaces and painted parts with a damp cloth and a mild to slightly alkaline cleaning solution (e.g., RBS® Neutral T) and wipe dry.

Chrome parts may only be wiped with a dry woollen cloth.

5.3.2 Disinfection

The disinfection must be performed in accordance with the current applicable legal requirements and guidelines corresponding for disinfection and explosion protection.

For disinfection of surfaces in contact with patients, we recommend commercially available medical rapid disinfection wipes (e.g., Dr. Schumacher Descosept Sensitive Wipes).

All mechanical parts of the PROGNOST C, including accessories, may only be cleaned with a wipe disinfection with suitable surface disinfectants (e.g., Melsept® SF, 15 min. application time at 2%

concentration). The information provided by the disinfectant manufacturer on concentrations and application times must be observed.

**WARNING!**

No highly flammable disinfectants may be used! For safety reasons, spray disinfection must not be carried out, as the spray mist could penetrate the device and cause short circuits or corrosion.

If disinfectants are used that can form explosive gas mixtures, the device may only be switched on again when the gas mixtures have evaporated!

5.4 Inspection and Maintenance

**WARNING!**

No maintenance or repair work may be performed while the PROGNOST C is being used with a patient!

All maintenance and repair work may only be performed by personnel trained or authorized by PROTEC.

5.4.1 Daily Monitoring before and during Examination Operation

- Check that the tabletop moves smoothly when the tabletop brake is released.
- Check the tabletop brakes when they are activated (tabletop should not be able to move)

5.4.2 Regular Monitoring

5.4.2.1 Quality control by the user

Quality controls for X-ray components must be performed at regular intervals in accordance with the relevant national guidelines.

- Check the surface of the tabletop for damages (dents, scratches, cracks, etc.)
- Check the movement of the components (tabletop, X-ray column, wall stand)

5.4.3 Maintenance

The required maintenance must be carried out by PROTEC service department or a service company authorized by them in order to ensure the safe and reliable functionality of the device. The maintenance intervals depend on the frequency of use. The required specifications can be found in the corresponding Technical Description in chapter 3 *Maintenance and Safety Inspection*.

In the event that the planned maintenance is not carried out, PROTEC X-ray Systems GmbH assumes no liability for damage to the user or third parties, if damage results from inadequate or not carried out maintenance.

Before starting the operation, the user must ensure that all the equipment concerning safety, listed in the instructions for use, are functional and that the device is ready for use.

See the technical description of the device.

Wear parts are to be replaced with original components.

In the event that the scheduled maintenance is not carried out, PROTEC X-ray Systems GmbH assumes no liability whatsoever for damage to the user and third parties if and to the extent that damage results from inadequate or non-performed maintenance.

Prior to test operation, the user must satisfy himself that all devices listed in the operating instructions and serving safety are in working order and that the product is ready for operation.

See the technical descriptions of the system.

Wear parts are only to be replaced with original parts.

5.4.4 Warranty



NOTE

You will find the current warranty conditions in your order documents or in the price list valid at the time of purchase.

Repairs and spare parts in the event of improper use are also excluded.
Warranty work may only be carried out by trained specialists.

5.4.5 Product Service Life

The PROGNOST C is designed for a service life of 7 years when used in accordance with the specifications and regular maintenance by PROTEC service department or a service company authorized by them. After the product has reached the end of its service life, further use is at your own risk.

5.4.6 Further Information

Detailed information to the individual chapters and for a safe operation, transport or storage can be found in the Technical Description of the PROGNOST C.

5.4.7 Applied Parts and Parts Considered as Applied Parts

Part	Definition (as applied part or parts which get handled like an application part but not defined as applied part)
Tabletop	Applied part
Cover / image receptor floor stand	Applied part
Patient extending handle (optional, mounted at the image receptor floor stand)	Part, considered as an applied part
Mattress (optional)	Part, considered as an applied part

5.4.8 Disposal Notes



The PROGNOST C contains various plastics and heavy metal. When disposing exchange and spare parts, or if necessary, the entire system, the valid rules and regulations must be observed. Please contact your contractual partner or service company or commission a company specialized in disposing the respective components.

6 Power Supply



HINWEIS

The PROGNOST C requires the following power supply:

Power supply	220-240 Vac
Power frequency	50-60 Hz
Input current	2,5 A



WARNING!

To avoid the risk of an electric shock, this device may only be connected to a supply network with a protective earth conductor.

6.1 Electromagnetic Compatibility (EMC) according to EN 60601-1-2



CAUTION!

As a medical electrical device, the PROGNOST C is subject to special precautionary measures regarding EMC and must be installed and commissioned in accordance with the EMC information contained in the accompanying documents.



CAUTION!

Portable RF communication devices (radio devices) should not be used closer than 30 cm (12 inches) to the marked parts and cables of the PROGNOST C. Failure to observe can lead to a reduction in the performance characteristics of the device.

6.1.1 Guidelines and Manufacturers Declaration – Electromagnetic Interference

The PROGNOST C is intended for use in the electromagnetic environment specified below. The customer or the operator of the radiographic system should assure that it is used in such an environment.

Measurement interference	Compliance	Electromagnetic Environment
RF emissions CISPR 11	Group 1	The X-ray component uses RF energy exclusively for its internal function. As a result, its RF emissions are very low and it is unlikely that nearby electronic devices will be influenced.
RF emissions CISPR 11	Class A	The device is suitable for use in facilities other than residential areas and those that are directly connected to the public supply network, which also supplies buildings that are used for residential purposes, provided the following warning is observed:
Harmonic emissions EN 61000-3-2	Class A	
Voltage fluctuations/ flicker emissions EN 61000-3-3	compliant	Warning: This device is intended for use by medical professionals only. This is a class A device according to CISPR 11. This device can cause radio interference in residential areas, in which case it must be necessary to take appropriate remedial measures such as new

		alignment, rearrangement or shielding of the device or filtering of the connection to the location.
--	--	---

Immunity Test	EN 60601-1-2 Test Level	Compliance Level	Electromagnetic Environment - Guidance
Electrostatic discharge (ESD) EN 61000-4-2	± 8 kV contact discharge ± 2 kV, ± 4 kV, ± 8 kV, ± 15 kV air discharge	± 8 kV contact discharge ± 2 kV, ± 4 kV, ± 8 kV, ± 15 kV air discharge	Floors should be made of wood, concrete or ceramic tiles. If the floor is covered with synthetic material, the relative humidity must be at least 30%.
Fast transient electrical disturbance variables / burst EN 61000-4-4	± 2 kV for power supply lines ± 1 kV for input/output lines	± 2 kV for power supply lines ± 1 kV for input/output lines	The quality of the supply voltage should correspond to that of a typical business or hospital environment.
Surges EN 61000-4-5	± 0,5 kV ± 1 kV ± 2 kV	± 0,5 kV ± 1 kV ± 2 kV	The quality of the supply voltage should be that of a typical commercial or hospital environment.
Magnetic field at the supply frequency (50/60 Hz) EN 61000-4-8	30 A/m 50/60 Hz	30 A/m 50/60 Hz	Magnetic fields at the mains frequency should correspond to the typical values found in a business and hospital environment.
Voltage dips, short interruptions and fluctuations in the supply voltage EN 61000-4-11	<5 % UT (>95 % dip in UT) for ½ cycle <5 % UT (>95 % dip in UT) for 1 cycle 70 % UT (30 % dip in UT) for 25/30 cycles <5 % UT (>95 % dip in UT) for 5/6s	<5 % UT (>95 % dip in UT) for ½ cycle <5 % UT (>95 % dip in UT) for 1 cycle 70 % UT (30 % dip in UT) for 25/30 cycles <5 % UT (>95 % dip in UT) for 5/6s	The quality of the supply voltage should correspond to that of a typical business or hospital environment. If the user of the device demands continued operation even if there are interruptions in the energy supply, it is recommended that the device be fed from an uninterruptible power supply or battery.
Conducted disturbances induced by RF fields EN 61000-4-6	3 V/m 1 kHz 80% AM 150 kHz bis 80 MHz	3 V/m	
Radiated RF disturbances EN 61000-4-3	3 V/m 1kHz 80% AM 80 MHz to 2.7 GHz	3 V/m	See table below

NOTE: These guidelines may not apply in all situations. Electromagnetic propagation is affected by absorption and reflection from structure, objects and people.

Test Frequency in MHz	Frequency Band in MHz	Service in MHz	Modulation	Immunity Testing Level in V/m
385	380 - 390	TETRA 400	Pulse modulation: 18 Hz	27
450	430 – 470	GMRS 460, FRS 480	FM ±5 kHz Deviation 1 kHz Sine	28
710 745 780	704 – 787	LTE Band 13, 17	Pulse modulation: 217 Hz	9
810 870 930	800 – 960	GSM 800/900, TETRA 800, iDEN 820, CDMA 850, LTE Band 5	Pulse modulation: 18 Hz	28
1720 1845 1970	1700 - 1990	GSM 1800, CDMA 1900, GSM 1900, DECT, LTE Band 1, 3, 4, 25, UMTS	Pulse modulation: 217 Hz	28
2450	2400 – 2570	Bluetooth, WLAN, 802.11 b/g/n, RFID 2450, LTE Band 7	Pulse modulation: 217 Hz	28
5240 5500 5785	5100 - 5800	WLAN, 802.11 a/n	Pulse modulation: 217 Hz	9

7 Technical Data

7.1 Dimensions

Room plan version 1 (operation of the system):

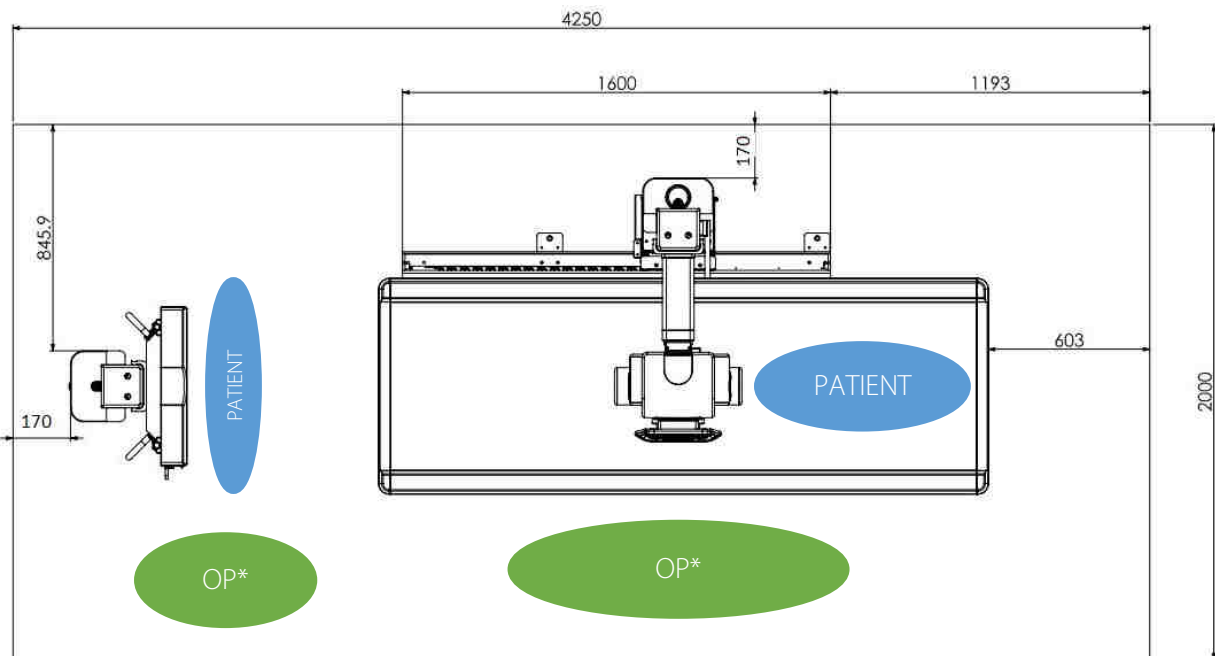
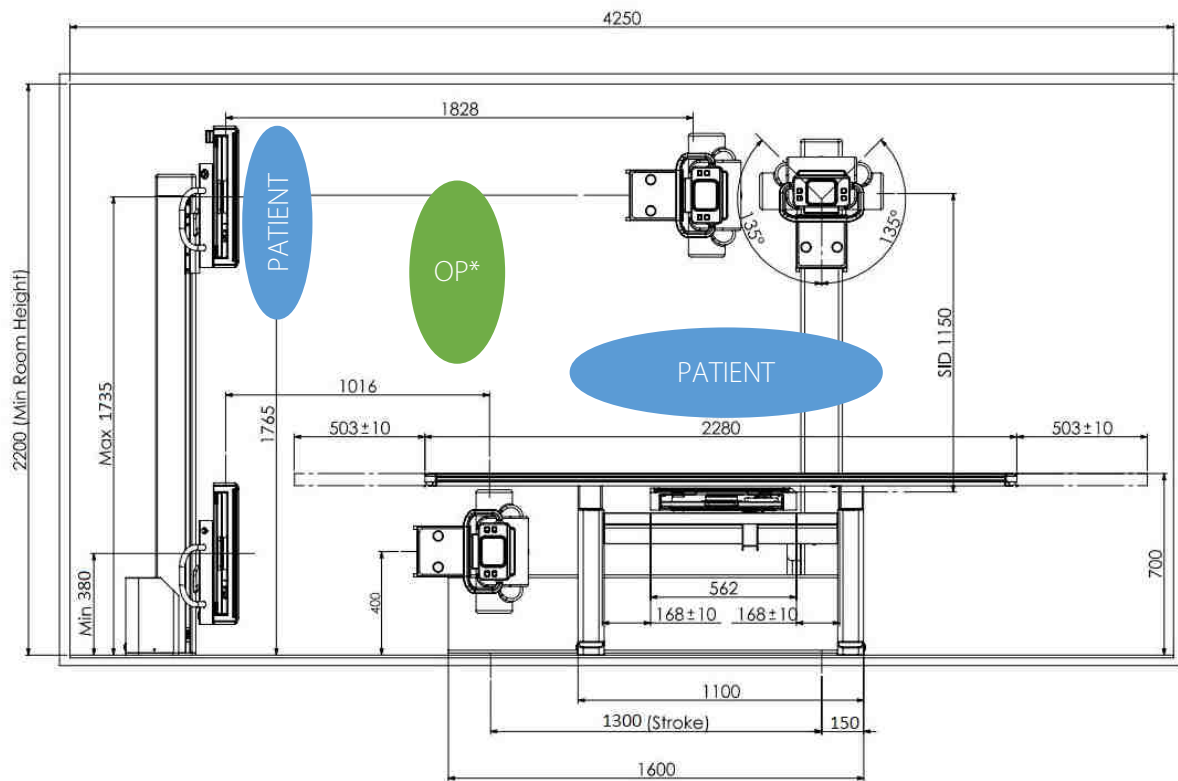

Room plan version 2 (Mounting and removing of the tabletop):

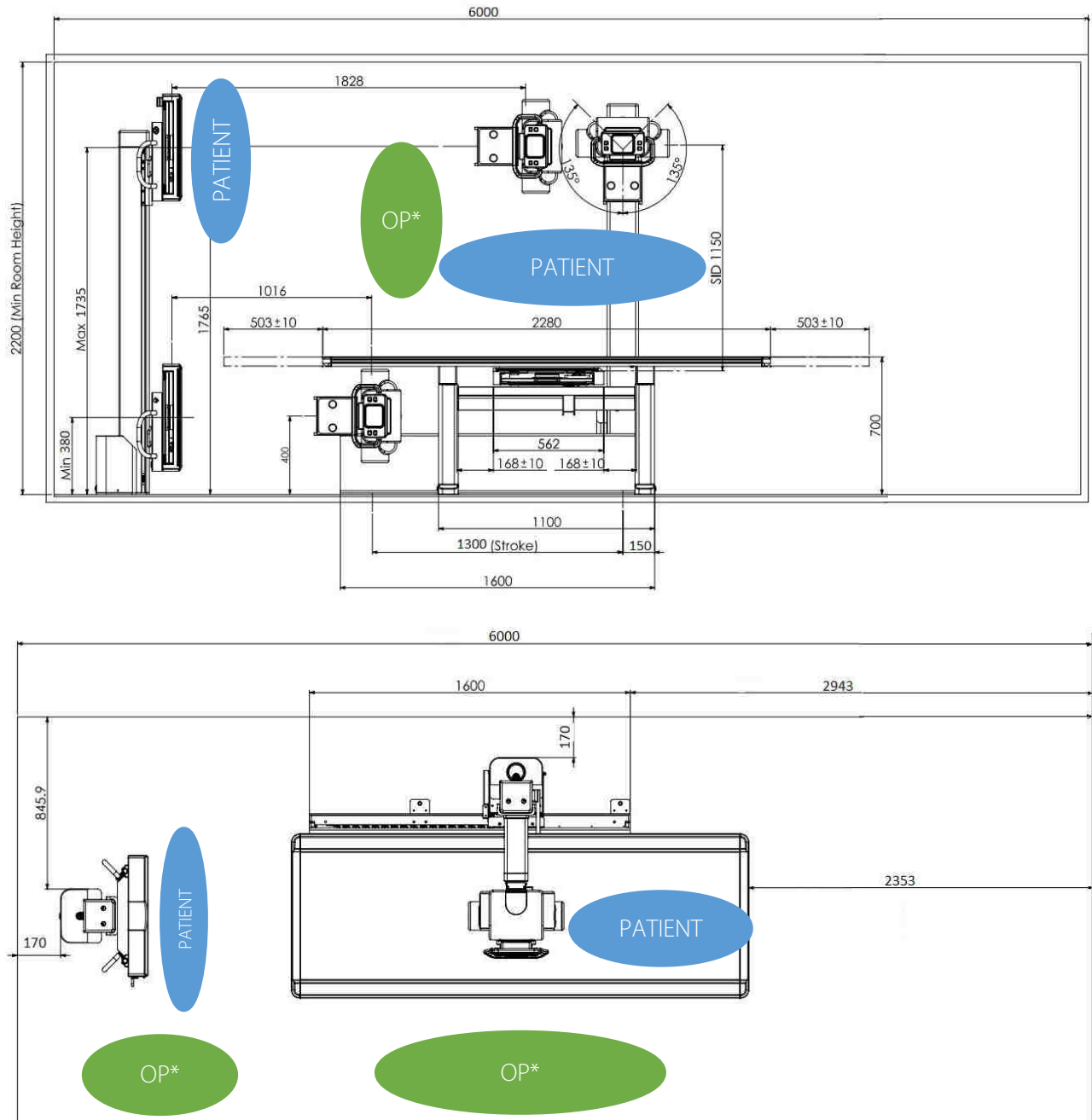

NOTE

The device requires a room size of at least **4250mm**, so that it can be fully operated in the room.

It should be noted that the tabletop can only be removed **from the side** of the table. To mount or remove the tabletop, the room must either have a size of at least **6000mm** or it is necessary to move components to have more space available.

7.1.1 Patient positioning table

Tabletop dimension (L x B):	2280 mm x 800 mm, standard
Max. safe working load table	250 kg
Tabletop height:	700 mm
Tabletop movement, transvers (from the mid-position):	± 100 mm
Tabletop movement longitudinal (from the mid-position):	± 500 mm

The brakes of the tabletop are used electro-mechanic.

7.1.2 Bucky unit

Longitudinal travel:	280 mm
Tabletop - film-distance:	75 mm

The Bucky unit and the measure chambers are connected to the generator.

7.1.3 X-ray stem tube support, floor stand

Focal spot vertical travel - horizontal X-ray beam:	400 mm – 1765 mm
Focal spot vertical – film distance:	max. 1150 mm
Rotation X-ray tube assembly around horizontal support arm:	$\pm 135^\circ$
Tube stand longitudinal travel:	1300 mm

7.1.4 Vertical X-ray system image receptor stand

Column height:	1850 mm
Vertical shift film centre:	380 mm – 1735 mm

7.2 Attenuation Equivalent



CAUTION!

The attenuation equivalent of the PROGNOST C may have to be considered during the acceptance test of the X-ray system.

The tabletop is defined as an applied part.

The aluminium attenuation equivalent of the tabletop is typically $1.1 < 1.2$ Al mm for composite fibre, according to EN 60601-1-3. Tested at 100 kV with a first half-value layer thickness of 3.6 mm Al and typically 0,6 mm Al und $<0,8$ mm Al according 21CFR § 1020-30 (n) with 100 kV and a first half-value layer thickness of 3.6 mm Al.

The Bucky cover of the image receptor stand is defined as an applied part.

The aluminium attenuation equivalent of the cover vertical wall stand is typically 0.5 and < 0.6 Al mm according to EN 60601-1-3. Tested at 100 kV with a first half-value layer thickness of 3.6 mm Al.

7.2.1 Protection Type and Protection Class

The PROGNOST C corresponds to protection class 1 and contains applied parts type B (according to EN 60601-1).

7.3 Environmental Conditions

7.3.1 Environmental Conditions during Operation



















Ambient Temperature	+ 10°C to 40°C
Relative humidity	30% to 75% (non-condensing)
Atmospheric pressure	700 hPa to 1060hPa



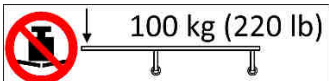

7.3.2 Environmental Conditions for Shipping and Storage

Ambient Temperature	- 10°C to + 70°C
Relative humidity	10% to 95% (non-condensing)
Atmospheric pressure	500 hPa to 1060hPa

8 Description of Symbols, Labels and Abbreviations

8.1 Symbols

	Atmospheric pressure limit
	Temperature limit
	Humidity limit
	Keep dry
	Fragile, handle with care
	This way up
	Attention, observe accompanying documents
	Refer to Instructions for use
	CE marking
	Classification according to EN 60601-1 (type B applied part)
	Caution: pinch-/crushing hazard for hands and fingers
	Do not exceed the maximum indicated weight
	Do not exceed the maximum indicated weight
	Manufacturer
	Medical Device
	Order reference
	Serial number
	Unique Device Identification

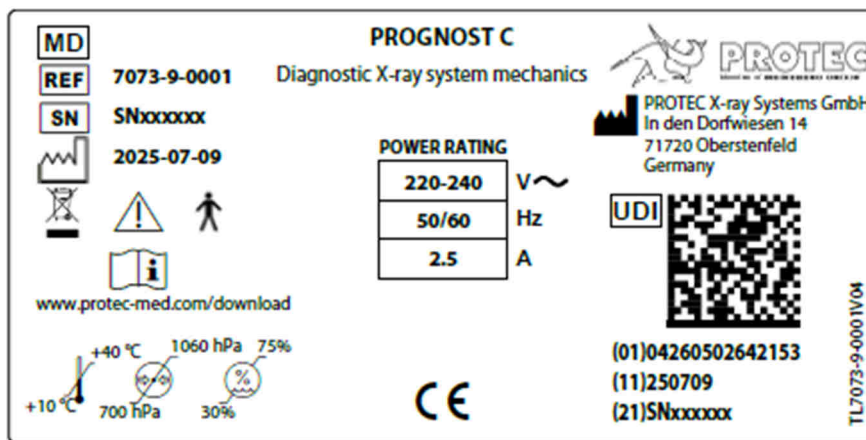

	<p>Production date</p>
 www.protec-med.com/download	<p>This symbol indicates the need to observe the instructions for use. This is provided in an electronic format (eIFU) on our website.</p>
	<p>Disposal instructions; WEEE (Waste of Electrical and Electronic Equipment)</p>
	<p>Protective earthing</p>

8.2 Type Label

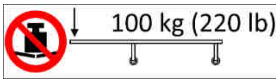

8.3 Labels

Labels on the tabletop

	<p>Caution: Watch out for possible crushing hazards to fingers or hands while moving the tabletop or X-ray unit.</p>
	<p>Maximum allowed weight (distributed load) for the tabletop</p>
	<p>Maximum allowed patient weight (distributed load) for the tabletop.</p>

Label on the tube column stand

	<p>Caution: Watch out for possible crushing hazards to fingers or hands while moving the tabletop or X-ray unit.</p>
---	--

8.4 Positions of the Signs and Labels

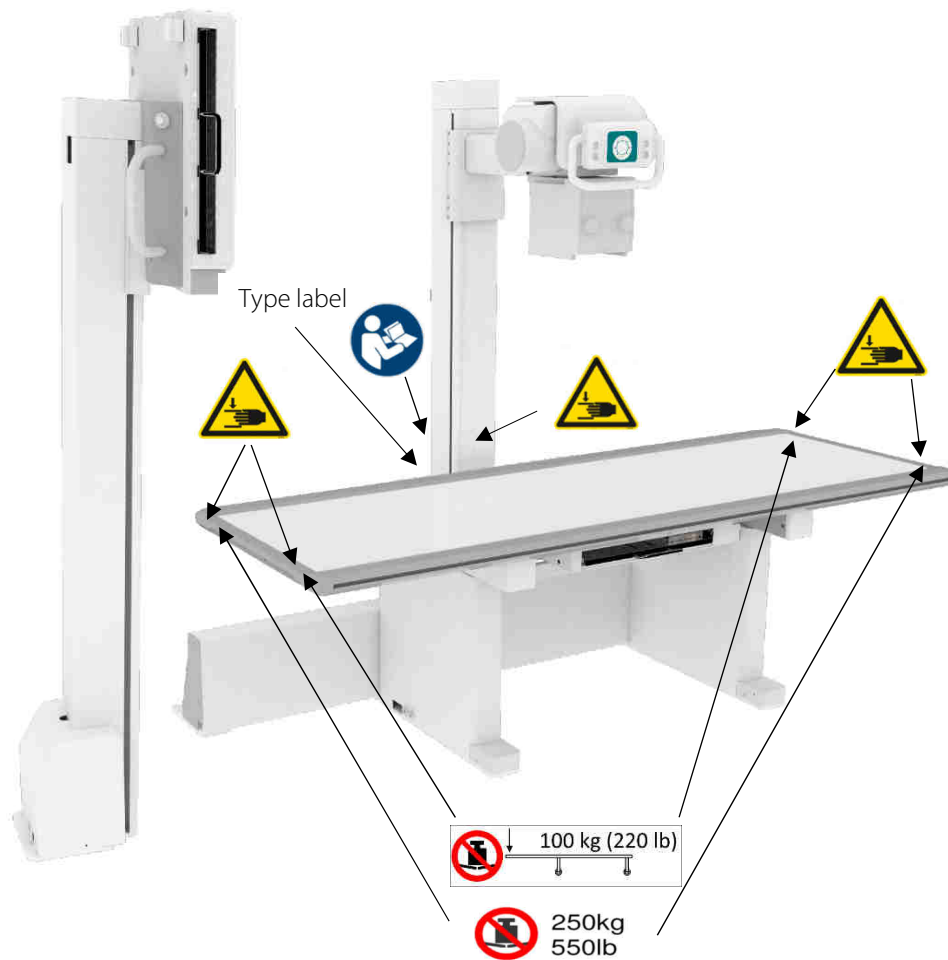

8.5 Abbreviations

mm	Millimetre
cm	Centimetre
lb	Pound
kg	Kilogram
°C	Degree -Celsius
hPa	Hectopascal
DIN	German Industry Standard
EN	European Standard
CE	CE-Mark
Hz	Hertz
ED	Duty cycle
A	Ampere
SN	Serial number