

PROGNOST E

Basic diagnostic X-ray system table, powered

Model/ID: 7043-5-87xx
Basic UDI-DI: 426050264X010ZC

Instructions for use

Ident. Nr. 5043-0-8002



**NOTE**

All sheets of this document contain proprietary and confidential information of PROTEC X-ray Systems GmbH and is intended for exclusive use by current PROTEC X-ray Systems GmbH customers. Copying, disclosure to others or other use is prohibited without the express written consent of PROTEC's law department. Knowledge of violations of these regulations must be reported immediately to PROTEC X-ray Systems GmbH.

© 2025 PROTEC X-ray Systems GmbH, Oberstenfeld

Comments and questions about the documentation, please contact:

PROTEC X-ray Systems GmbH

In den Dorfwiesen 14 | 71720 Oberstenfeld
Germany

Phone: (+ 49) 7062 – 92 55 0

Fax: (+ 49) 7062 – 92 55 60

E-Mail: protec@protec-med.com

Internet: www.protec-med.com

Table of contents

	Page
Table of contents	3
Revision Status	5
General Notes	6
Mechanical and Electric Warning	6
To the User	6
1 Device Description	7
1.1 Introduction	7
1.2 Description.....	7
1.2.1 Versions	7
1.2.2 Hardware and Network System Requirements	7
1.2.3 Installation	8
1.2.3.1 Floor Loading Capacity.....	8
1.3 Performance Characteristics	8
1.3.1 Height Adjustable X-ray System Table.....	8
1.4 Intended Use	8
1.5 Clinical Benefit	9
1.6 Patient Target Group(s).....	9
1.7 Medical Conditions to be diagnosed	9
1.8 Indications and Contraindications	9
1.9 Intended User Group.....	9
1.10 Declaration of Conformity.....	9
2 Safety Instructions	10
2.1 General Safety Instructions.....	11
2.1.1 Requirements for operation	11
2.1.2 Device Operation	11
2.1.2.1 Operating Type	11
2.1.3 Operating Personnel	11
2.1.4 Crushing and Collision Hazard	11
2.1.5 Explosion Protection	11
2.1.6 Interaction with Other Devices.....	11
2.1.7 Electromagnetic Environment and Influencing of Devices	12
3 Control Elements and Displays	13
3.1 Main Switch of the PROGNOST E.....	13
3.2 Emergency Stop Switch of the PROGNOST E.....	13
3.3 Control Elements and Display of the PROGNOST E.....	13
3.3.1 Foot switch.....	14
3.3.2 Hand grip (optional).....	14
3.3.3 Emergency stop switch, Signal LED and acoustic signals.....	14
3.3.3.1 Acoustic Status Indications.....	16
3.3.3.2 Acoustic and Visual Status Indications at Column Drive Blockage	16
3.4 Bucky cassette tray.....	16
4 Handling	18
4.1 Requirements before and during Operation.....	18
4.2 Operation of the PROGNOST E.....	18
4.2.1 Releasing the tabletop brake and positioning the tabletop	18
4.2.2 Height adjustment of the tabletop.....	18
4.2.3 Zero balance performance with the foot switch.....	19
4.2.4 Operation at the PROGNOST E.....	19
4.3 Function of the PROGNOST E.....	20
4.3.1 Switching the PROGNOST E on and off.....	20
5 Safety and Maintenance	21
5.1 Introduction	21

5.2	Reusability	21
5.3	Cleaning and Disinfection	21
5.3.1	Cleaning	21
5.3.2	Disinfection	21
5.4	Inspection and Maintenance	22
5.4.1	Daily Monitoring before and during the Examination Operation	22
5.4.2	Regular Monitoring	22
5.4.2.1	Quality control by the operator	22
5.4.2.2	Safety-related controls	22
5.4.3	Maintenance	23
5.4.4	Warranty	23
5.4.5	Product Service Life	23
5.4.6	Further Information	23
5.4.7	Applied Parts and Parts Considered as Applied Parts	23
5.4.8	Disposal Notes	23
6	Power Supply	24
6.1	Electromagnetic Compatibility (EMC) according to EN 60601-1-2	24
6.1.1	Guidelines and Manufacturer's Declaration – Electromagnetic interference	24
7	Technical Data	27
7.1	Dimensions	27
7.2	Attenuation Equivalent	28
7.2.1	Protection Type and Protection Class	28
7.3	Environmental Conditions	28
7.3.1	Environmental Conditions during Operation	28
7.3.2	Environmental Conditions for Shipping and Storage	28
8	Description of Symbols, Labels and Abbreviations	29
8.1	Symbols	29
8.2	Type Label	30
8.3	Labels	30
8.4	Positions of the Signs and Labels	32
8.5	Abbreviations	32

**NOTE**

The information contained in this document conforms to the configuration of the equipment as of the date of manufacture. Revisions to the equipment subsequent to the date of manufacture will be addressed in service updates distributed to the PROTEC Technical Service Organisation.

Revision Status

Revision	Date	Updated pages	Comments	Author
1.0	2019-05-14	all	Newly created. Replace document 5045-0-0002_Rev06	
2.0	2019-08-27	Page 28, 29 chap. 2.1.7 chap. 3.2 chap. 6.1.1 Chap. 8.2	Changed illustration dimension, changed weight Attention-note inserted Chapter renamed EMC tables removed Identification label updated	
3.0	2020-08-11	Front page, Cap. 5.3.3	Maintenance updated	
4.0	2020-11-24	Front page	Model ID revised	
5.0	2021-05-26	all	V4.0 transferred to new layout (MDR)	MB
6.0	2022-10-26	Chap. 3.3.3	Error messages via signal LED and acoustic signals adapted, Information about zero balance performance during initial commissioning added, Reference to form Picture / labeling changed due to new handles, Chapter renamed.	TB
		Chap. 4.2		
		Page 10		ML
		Chap. 3.3		TB
7.0	2022-12-07	Chap. 1.2.1	Optional Accessories corrected	ML
8.0	2024-04-08	Chap 4.2.1	Positioning of the tabletop optimised	DP
9.0	2025-07-16	All	First edition PROTEC X-ray Systems GmbH	ML

General Notes

**WARNING!**

In order to maintain the set and tested requirements of the 60601 series of standards, the ME system must not be modified during its actual operating life.

Mechanical and Electric Warning

**WARNING!**

All of the movable assemblies and parts of this equipment should be operated with care and routinely inspected in accordance with the manufacturer's recommendations contained in the equipment accompanying documents. Maintenance and service is only to be performed by customers authorized by PROTEC X-ray Systems GmbH.

Live electrical terminals are deadly.

Do not remove flexible high-tension cables from X-ray tube cover or high-tension generator and/or access covers from X-ray generator.

For all components of the equipment protective earthing means must be provided in compliance with the national regulations.

Failure to comply with the foregoing may result in serious or fatal bodily injuries to the operator or those in the area.

To the User

**NOTE**

The user of these accompanying documents is required to carefully read through and carefully consider the instructions, warnings and cautions contained therein before starting operation.

Even if you have already operated similar systems, changes in the design, production and functional routine of the system described here may have been made, which have a significant influence on the operation.

Assembly and service works on the system described here must be carried out by authorised and qualified personnel from PROTEC X-ray Systems GmbH. Assembly personnel and other persons who are not employees of the technical service department of PROTEC X-ray Systems GmbH are requested to contact the local branch of PROTEC X-ray Systems GmbH before assembly or service work is started. For assembly and service works, it is necessary to use the "Technical Description" of the product and to observe the points it contains.

**NOTE**

The use of the product with add-on or accessory parts not authorized by PROTEC or other unapproved components is not permitted.

**NOTE**

According to Regulation (EU) 2017/745 of medical devices, all serious incidents related to the device must be reported to the manufacturer and the responsible authority of the Member State where the user and/or the patient is established.

1 Device Description

1.1 Introduction

The instructions for use describe the performance characteristics and operation required for efficient and effective use of the PROGNOST E.

Before you work with the PROGNOST E, the complete instructions for use must be read, especially the Safety Instructions and the chapter Handling.

1.2 Description

The PROGNOST E X-ray system table consists of a moving grid table with a floating tabletop. It is designated for the installation of a running grid device that can be manually moved in longitudinally direction with an electronic drive for an anti-scatter grid and a 3-field measuring chamber for operation with automatic exposure control.

Non-operated the floating tabletop of the X-ray system is locked in longitudinal and transverse directions by highly effective pedo-mechanical brakes. The motor-operated tabletop brake and the electrical height adjustment of the tabletop can be actuated via the foot switch. The ease of movement of the tabletop and its large adjustment range allow comfortable positioning of the patient.

1.2.1 Versions

PROGNOST E 7043-5-87xx

Tabletop versions

Model ID	Material	L	W	Tabletop colour
7301-0-5900	carbon fibre	200 cm	75.5 cm	white
7301-0-2200	carbon fibre	226 cm	75.5 cm	white
7301-0-6000	composite fibre	200 cm	75.5 cm	white
7301-0-6010	composite fibre	226 cm	75.5 cm	white
7301-0-6020	composite fibre	200 cm	65.5 cm	white

Optional Components

- X-ray cassette holder (Bucky or Grid entity)
- Measuring chamber (ionization or solid state)
- Anti-scatter grid

Optional Accessories

- Mattress
- Ball knob grab handle, for a fine positioning of the patient on the 4-way tabletop
- Handle long, for facilitating the positioning and descending of the patient
- Shock protection profile, for rear tabletop accessory rail
- Compression band
- Detector holder lateral, incl. 2 handles*

*Accessories with medical purpose

Accessories that can influence the EMC conditions

- Network cable (note the max. cable length in the component documentation)
- WiFi router (Only use devices approved by PROTEC)

1.2.2 Hardware and Network System Requirements

As a stand-alone product, the PROGNOST E has no hardware or network connection and therefore no hardware or network requirements

1.2.3 Installation



NOTE

The installation of the PROGNOST E must be performed by PROTEC service department or a service company authorized by them.

For more information, please see separate "Installation manual PROGNOST E."

Contact information of persons qualified to perform installations are available upon request at:

PROTEC X-ray Systems GmbH

In den Dorfwiesen 14 | 71720 Oberstenfeld
Germany

Phone: (+ 49) 7062 – 92 55 0

Fax: (+ 49) 7062 – 92 55 60

E-Mail: protec@protec-med.com

Internet: www.protec-med.com

1.2.3.1 Floor Loading Capacity



NOTE

The PROGNOST E is primarily made of metal pieces. This has a corresponding effect in the weight of the device.

The PROGNOST E has a weight of 212kg.

Every technician is obliged to check the floor load. Raised floors and hollow floors must also be considered.

1.3 Performance Characteristics

1.3.1 Height Adjustable X-ray System Table

- Variable table height
 - PROGNOST E (58.9cm – 87,6 cm)
- Variable tabletop size
 - Standard: 226 x 75,5 cm
 - Optional: 200 x 75,5 cm
- Floating tabletop
- Tabletop colour white
- Motor activated tabletop brake for effortless patient positioning
- A low (optimized) distance between the tabletop surface and the film (detector) surface
- Large adjustment range of the tabletop for position of the patient
- Lateral rails of the tabletop prepared to attach accessories
- Prepared for the installation of a Bucky with anti-scatter grid and 3-field measuring chamber intended for the use with automatic exposure control
- Extensive cassette program including format 13 cm x 18 cm up to format 43 cm x 43 cm
- High reliability

1.4 Intended Use

The PROGNOST E stationary X-ray system table is intended to be used as an electrically operated component of a diagnostic X-ray system for patient positioning for various routine applications in planar X-ray imaging in human medicine.

1.5 Clinical Benefit

Considered in isolation, no clinical benefit can be shown for X-ray system tables.

As components of diagnostic X-ray systems in human medicine, they contribute to the clinical benefit of X-ray systems, which consists of the generation of conventional two-dimensional X-ray images for creation or specification of findings as a basis for treatment decisions.

1.6 Patient Target Group(s)

The intended patient group includes all people for whom a justifying indication for a medical X-ray has been given by a physician with the necessary expertise in radiation protection.

There are no general or fundamental restrictions on the patient group regarding age, gender, origin and patient condition.

1.7 Medical Conditions to be diagnosed

As standalone products, X-ray system tables, have no function to diagnose, treat and/or monitor medical conditions.

1.8 Indications and Contraindications

As standalone products, X-ray system tables have no intended main effect in or at the human body. Therefore, considered in isolation, no indications or contraindications can be shown for them

1.9 Intended User Group

As a component of a diagnostic X-ray system, PROGNOST E is intended exclusively for use by professional users who are trained in the operation of diagnostic X-ray systems in accordance with the respective national regulations and who are familiar with the proper handling, use and operation and also have been instructed in the permitted conjunction with other medical products, objects and accessories.

Appropriate users can be, for example: X-ray technicians, X-ray assistants, medical technical X-ray assistants, surgeons, casualty surgeons, orthopaedists and other trained medical personnel.

1.10 Declaration of Conformity



This product complies with the requirements of Regulation (EU) 2017/745 of the European Parliament and of the Council of 5 April 2017 on medical devices, including all applicable corrigenda.

The declaration of conformity is available upon request from PROTEC:

PROTEC X-ray Systems GmbH

In den Dorfwiesen 14 | 71720 Oberstenfeld
Germany

Phone: (+ 49) 7062 – 92 55 0

Fax: (+ 49) 7062 – 92 55 60

E-Mail: protec@protec-med.com

Internet: www.protec-med.com

2 Safety Instructions



NOTE

Contains information that must be observed during operation.

xxx



CAUTION!

Contains information which, if not observed, can cause property damage.

xxx



WARNING!

Contains information which, if not followed, can cause personal injury.

xxx



WARNING!

Warning of radioactive substances or ionizing radiation. Contains information which, if not observed, can cause personal injury.

xxx

Settings and calibrations that are not described in these instructions for use must be carried out using the technical description of the device by PROTEC service department or a service company authorized by them.



NOTE

All instructions supplied with the PROGNOST E must be observed and the safety instructions contained therein must be carefully read and adhered to.



NOTE

After the initial installation, the commissioning must be recorded with the PROTEC acceptance protocol FB-04-07A4.3.



NOTE

The PROGNOST E may only be commissioned if all safety measures for operator protection have been met and checked. These protective measures can include door contact, designated area, dosimeter, protective clothing, etc.



CAUTION!

The instructions for use contain all the information relevant to safety in order to generally put the PROGNOST E into operation. The device may only be operated by appropriately trained and trained personnel. In this context, operation is ensured by clear symbols on the control elements. All further information and instructions can be found on the supplied data carrier (USB, CD or DVD). This information applies in its entirety as an appendix to these instructions for use and must be observed.



NOTE

All control elements are described again in detail in these operating instructions.

2.1 General Safety Instructions

2.1.1 Requirements for operation



WARNING!

The PROGNOST E is a protection class I device (according to EN 60601-1). To avoid the risk of an electric shock, this device may only be connected to a supply network with a protective earthing conductor. The power supply for the PROGNOST E of the X-ray system is exclusively made by direct connection to the X-ray generator or the Power Box and is permanently connected there. The X-ray generator or the Power Box must have at least 2 connections for 230V 50/60Hz. The X-ray generator of the X-ray system is connected to the supply network (see technical description of the X-ray generator). To reduce the risk of electric shock, the system must be connected to a supply network with protective earthing. The system does not have an on/off switch. It is switched on or off directly by switching on the X-ray generator or by the switch on the Power Box. In order to separate any electrical voltage from the X-ray system, the connected X-ray generator or the Power Box must be switched off.

2.1.2 Device Operation

In case of a malfunction, do not use the PROGNOST E anymore and notify PROTEC service department or a service company authorized by them.

2.1.2.1 Operating Type

The PROGNOST E is not intended for continuous operation.
Duty Cycle: S3 15% - maximum continuous operation of 1,5 minutes.

2.1.3 Operating Personnel



NOTE

Only trained and authorized personnel are allowed to work on the PROGNOST E.



NOTE

The operating personnel must be familiar with all warning signs attached to the PROGNOST E. They are used for your own safety and that of others and ensure proper operation.

2.1.4 Crushing and Collision Hazard



WARNING!

It must be ensured that when operating the moving parts of PROGNOST E, no persons or objects are in the obvious danger area of the device. If not observed, it can result in personal injury or damage to the PROGNOST E or other objects.

2.1.5 Explosion Protection

The PROGNOST E is not designated for use within areas with explosive hazards.

2.1.6 Interaction with Other Devices

Interactions with other devices are not known.

2.1.7 Electromagnetic Environment and Influencing of Devices

**CAUTION!**

The use of other accessories, other converters and other cables than those specified by PROTEC or provided in the documentation of the component manufacturer can result in increased electromagnetic interference or reduced electromagnetic immunity of the device and lead to defective operation.

**CAUTION!**

The use of the PROGNOST E immediately next to other devices or with other devices in a stacked form should be avoided, as this could result in defective operation. If use in the manner described above is nevertheless necessary, the PROGNOST E and the other devices should be observed to ensure that they are working properly.

**NOTE**

The properties of this device, determined by emissions, allow its use in industrial areas and in hospitals (CISPR 11, class A). When used in residential areas (for which class B is usually required by CISPR 11), this device may not provide adequate protection for radio services. The user may need to take remedial measures such as relocating or realigning the device.

The PROGNOST E is intended for use in an environment in professional health care facilities (e.g. clinics, surgery centres, physiology practices ...).

3 Control Elements and Displays

3.1 Main Switch of the PROGNOST E

The PROGNOST E does not have a main switch.

3.2 Emergency Stop Switch of the PROGNOST E

The PROGNOST E has the following emergency stop switch, which can be used to bring the device to an immediate standstill and disconnect it from the power supply.



3.3 Control Elements and Display of the PROGNOST E

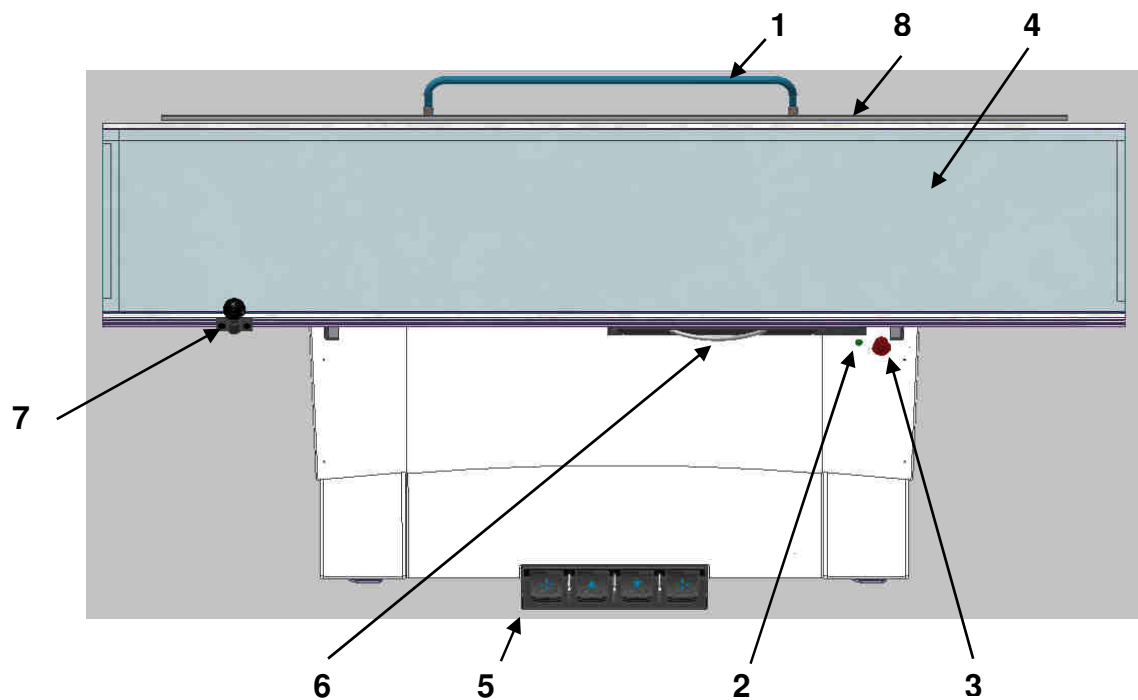

- 1 Long hand grip RAL 5021 (optional)
- 2 Signal LED
- 3 Emergency stop switch
- 4 Tabletop
- 5 Foot switch
- 6 Bucky cassette tray
- 7 Short hand grip (optional)
- 8 Bumper profile (optional)

3.3.1 Foot switch

- 1 Release the tabletop brake. The tabletop can be moved floating by hand.
- 2 Height adjustment of the table. The tabletop moves upwards.
- 3 Height adjustment of the table. The tabletop moves downwards.
- 4 Release the tabletop brake. The tabletop can be moved floating by hand.

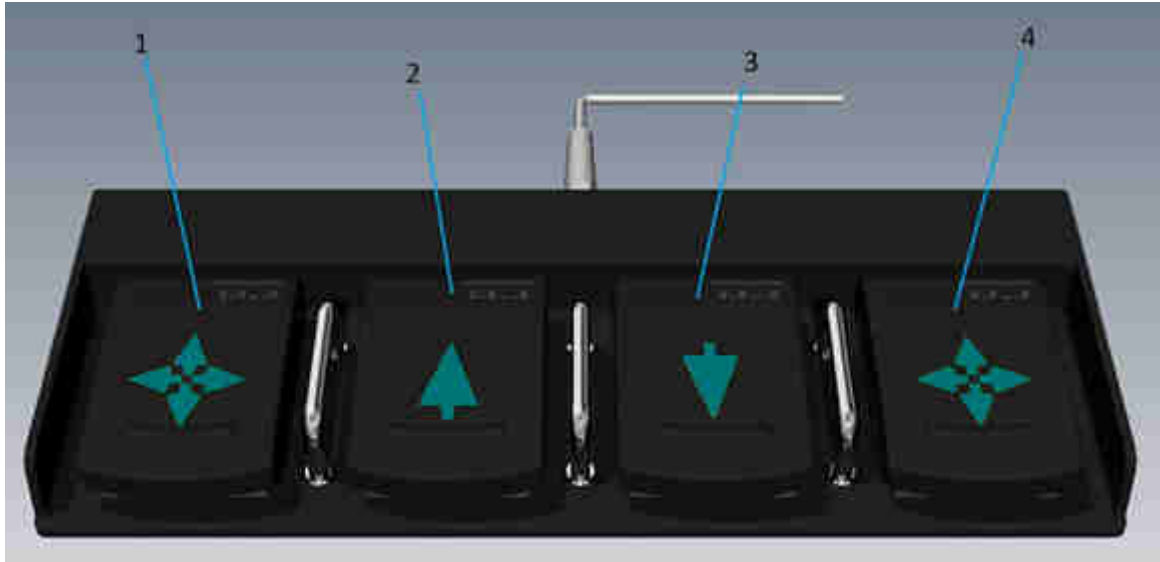

NOTE

Functions that are controlled by a foot switch are only executed by "double-clicking" the switch.

The switch must be actuated 2x within 1.5 seconds and then in continuous actuation to perform the function. When the switch is no longer actuated, the movement / function is stopped.

3.3.2 Hand grip (optional)

A long handle for the back of the tabletop and 2 handles for the front of the tabletop are available as options. Both handles can only be removed with tools. The long handle is intended for easier ascending and descending of the patient. The tabletop can be better shifted with the short handles.

3.3.3 Emergency stop switch, Signal LED and acoustic signals

By actuating the emergency stop switch, the control, the drives of the tabletop brakes and the drive for the height adjustment are switched off.

The emergency stop switch is unlocked by turning it clockwise.

Next to the emergency stop switch there is a two-colour signal LED, which indicates operational readiness and status messages.



CAUTION!

Even if the emergency stop switch has been operated and the signal LED does not light up, voltage may still be applied to the device. Only by switching off the power supply of the generator, the table safely disconnected from the power supply.

The following is an overview of the signal LED status display

Signal LED green	Device is ready for operation
------------------	-------------------------------

Status messages are generated by cyclic flashing of the signal LED in the colour red.

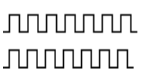
State	Flashing rhythm red	Description	Measure
1	1x 	Check DIP switch.	Take the device out of operation and notify PROTEC authorized service.
2	2x 	Drive (lifting columns) blocked, Or: Defective cable or plug is disconnected.	Check whether the table plate is blocked in the downward / upward movement. Move the table in the opposite direction of the blockage. If the error message persists, notify PROTEC authorized service.
3	3x 	Overload, excessive patient load and thus excessive current consumption of the drives (lifting columns).	Reduce the patient load and allow the device to cool down at a standstill. If the cause has been eliminated, the status messages can be deleted by briefly pressing the foot switch.
4	4x 	Unintentional movement, e.g., downwards due to impermissibly high patient load.	Reduce the patient load. Notify PROTEC authorized service.
5	7x 	The control system has detected on the way up that there is a cable break to the limit switch in the lifting column.	Take the device out of order and notify PROTEC authorized service.
6	8x 	Height difference of the lifting columns, there is 1.5 cm difference in the position (height) of the lifting columns. (When restarting / replacing the board, this error message comes automatically).	Perform zero adjustment Notify a PROTEC authorized service if the error message reoccurs after the zero balance.
7	9X 	Blocking the tabletop brake.	Take the device out of order and notify PROTEC authorized service.
8	10X 	Duty cycle of the lifting columns exceeded.	Allow the device to cool down at standstill until signal LED changes from red flashing rhythm to bright green again.

**NOTE****State message 2,4 and 5:**

If these state messages can be deleted with the foot switch button and then occur again, the PROTEC authorized service must be notified and the table must be taken out of order.

3.3.3.1 Acoustic Status Indications

For all signal lamps state messages, a one-time acoustic message is given by the built-in beeper.

State	Beeping sound	Description	Measure
1	2x 	General Warning	Observe the blinking rhythm of the signal LED of the lifting columns or of the table.
2	Continuously	1. Overload, excessive current consumption of the drives. 2. Or: blocking of the tabletop brake.	1. See status message 3 in chap. 3.3.3. 2. see status message 7 in chap. 3.3.3.

**CAUTION!**

If the drive is blocked during operation, the movement of the height adjustment must be stopped and the obvious blockage of the height adjustment (e.g., due to the tabletop resting on an object) must be rectified. If the cause of the blockage is not obvious (e.g., internally blocked drive column), the height adjustment must be taken out of order and the service authorized by PROTEC must be notified.

3.3.3.2 Acoustic and Visual Status Indications at Column Drive Blockage

In the event of a blocked column drive, a visual indicator lamp status message is issued in combination with a one-time acoustic warning.

If a height difference of >1,5cm between the drive columns is detected by the control, height adjustment is no longer permitted (height adjustment automatically disabled).

A maximum duty cycle (ED) of 15% is prescribed for the drive columns in order to avoid overloading the column and to achieve a long service life. This is implemented in the control system in such a way that the height adjustment of the table is prevented after the factory-set time and an error message (10x flashing, see table) is displayed. This forces a pause of 4 minutes, as no height adjustment can be made. The internal time is then reset that the table height can be adjusted again. In order to have the complete travel time available again, the table must be left switched on for at least 15 minutes without making a table height adjustment.

3.4 Bucky cassette tray

The cassette tray is used to hold the X-ray film cassettes.

The cassette tray (1) can be pulled out of the Bucky by the handle (3) until the limit stop to insert the cassette. The cassette is locked by the clamping device (2). The cassette is automatically centred in transverse direction. In the longitudinal direction, the cassette can be positioned manually by aligning

it according to the center markings **(4)** or by setting the cassette positioner to the corresponding cassette size.

The movement range of the Bucky is 545 mm.

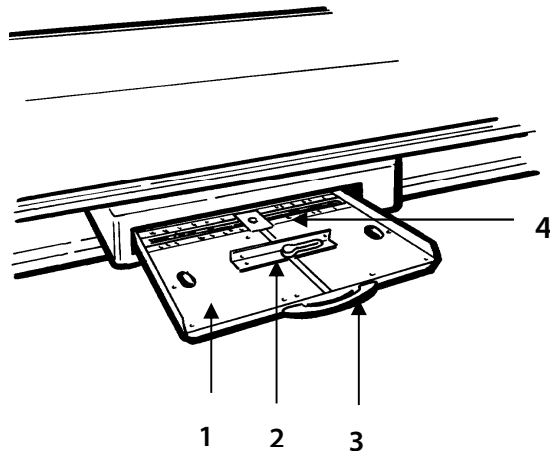

4 Handling

4.1 Requirements before and during Operation

It must be ensured that the surfaces in contact with patients are disinfected before the X-ray examination of each patient (see chapter 5.3.2).

4.2 Operation of the PROGNOST E



WARNING!

Perform a zero balance of the lifting columns before initial startup of the X-ray table (see chapter 4.2.3)!

4.2.1 Releasing the tabletop brake and positioning the tabletop



NOTE

Prior to patient positioning, the X-ray unit must be brought into the required exposure position.



WARNING!

The tabletop may only be locked when the tabletop is in the rest position, not while it is being moved.

1. Release the tabletop brakes by double-clicking on one of the two-foot switches.
2. Move the floating tabletop to the desired position by hand while keeping the foot switch pressed.
3. When the tabletop is in the rest position, release the foot switch and the tabletop will be locked again by the brakes.

Tabletop displacement from the central position:

Transverse direction	± 150 mm
Longitudinal direction	± 330 mm (2m tabletop)
	± 460 mm (2.26 m tabletop)

4.2.2 Height adjustment of the tabletop

By double-clicking on one of the two foot switches, the tabletop can be moved up or down. In the end position, the drive is automatically stopped.



CAUTION!

It is recommended that the X-ray system table only be operated from the front while in standing position. Operating the X-ray system table from a seated position should be avoided as there is a possibility of trapping the leg between the tabletop and the foot control when the tabletop is lowered (only if the tabletop is on the front position). If the X-ray system table must be operated in a seated position, it is essential to ensure that the tabletop is positioned at the rear.

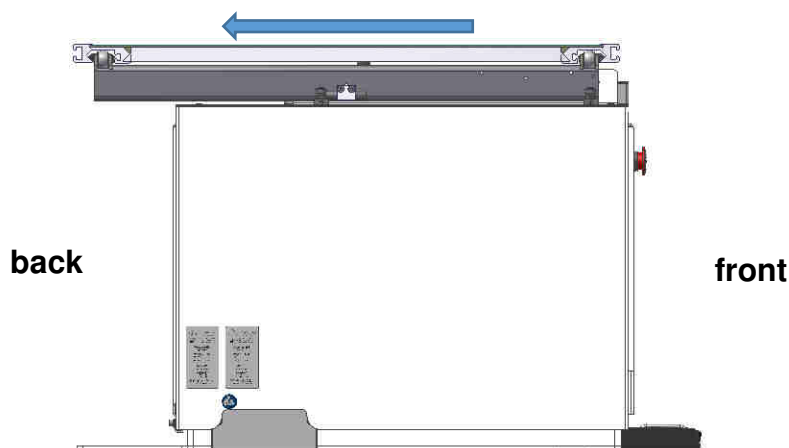

4.2.3 Zero balance performance with the foot switch

At the first commissioning, or if differences in the tabletop height are visible, the control unit must be referenced.



CAUTION!

If there are visible differences in the table height, the tabletop could start moving by itself if the brakes are released.

For adjustment, the foot switch for upwards movement must be actuated and held. After 4 seconds of continuous actuation, the control beeps once. Immediately after the sound, the foot switch for downwards movement must be actuated and held. After a few seconds the lifting columns move slowly downwards. The zero adjustment takes place in the lower end position and therefore moves the table all the way down. **The foot switch for downwards movement must be actuated until the end of the zero adjustment.** When both lifting columns are in the end position, the position is set to 0 and the control will beep once for a long time. The zero adjustment has been completed and the foot switch no longer needs to be actuated.



CAUTION!

Never carry out the zero balance with a positioned patient.

4.2.4 Operation at the PROGNOST E

- Move the table height and the tabletop to a position in which the patient can climb onto the table surface as easily as possible.



NOTE

The PROGNOST F is only used for positioning the patient during the examination. The Patient may only ascend and descend under the supervision or assistance of the examiner, otherwise there is risk of injury!

If the patient weighs more than 150 kg, the user should always follow the steps for ascending and descending the patient:

- Move the tabletop completely to one side (left or right).
- Slide the Bucky cassette drawer to the other side.
- Position the tabletop as centred as possible (back/front).
- The patient should ascend and descend in the middle of the tabletop (green arrow).

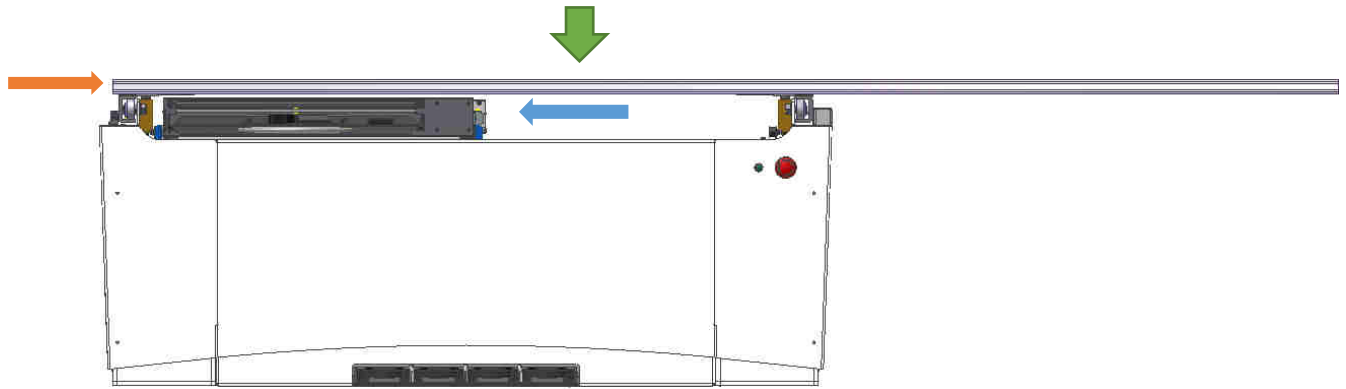

- Position patients for the exposure. If necessary (e.g., open wounds), cover the table surface with suitable cloths or disposable care pads.



WARNING!

Danger of crushing at the table edges and danger of trapping on and below the tabletop!

When the tabletop is moved horizontally and the table is moved vertically, extremities can be trapped between the edge of the table and a fixed obstacle (wall, tube column, X-ray equipment).

Therefore, when using the PROGNOST E, make sure that neither the patient nor the personnel are standing in the direction of movement.

In particular, make sure that no extremities of the patient protrude over the edge of the tabletop. The patient must also be informed that all body parts should remain unmoved on the tabletop.

4.3 Function of the PROGNOST E

4.3.1 Switching the PROGNOST E on and off

The PROGNOST E starts with applying of a power supply and is not started separately.

5 Safety and Maintenance



WARNING!

Caution, risk of electric shock!

Switch off the PROGNOST E before cleaning or disinfecting. This disconnects the PROGNOST E from the power source and avoids the risk of electric shock.

5.1 Introduction

In this chapter you will find information about safety and maintenance that are necessary to ensure the correct and reliable function of the device after installation.

5.2 Reusability

The PROGNOST E can be reused without any special preparation procedures.

However, it must be ensured that the surfaces in contact with patients are disinfected before the X-ray examination of each patient (see also chapter 4.1).

The PROGNOST E must no longer be used with patients if it shows signs of wear (e.g., metal abrasion, wear of insulations) or dangerous technical defects (e.g., bent parts) or if the resulting image quality (e.g., artifacts in the image) is insufficient.

In this case, please contact PROTEC service department or a service company authorized by them immediately.

5.3 Cleaning and Disinfection



NOTE

Caution!

Possible material changes!



WARNING!

Make sure that no liquid enters the interior of the housing during cleaning and disinfection in order to prevent electrical short circuits and/or corrosion.

5.3.1 Cleaning

The cleaning of the PROGNOST E is very easy due to the very good quality surface coating. This is usually only done with a dry cloth.

Do not use corrosive, dissolving or abrasive cleaning agents, which could damage the device surfaces or the coating.

Clean the device surfaces and painted parts with a damp cloth and a mild to slightly alkaline cleaning solution (e.g., RBS® Neutral T) and wipe dry.

Chrome parts may only be wiped with a dry woollen cloth.

5.3.2 Disinfection

The disinfection must be performed in accordance with the current applicable legal requirements and guidelines corresponding for disinfection and explosion protection.

For disinfection of surfaces in contact with patients, we recommend commercially available medical rapid disinfection wipes (e.g., Dr. Schumacher Descosept Sensitive Wipes).

All mechanical parts of the PROGNOST E, including accessories, may only be cleaned with a wipe disinfection with suitable surface disinfectants (e.g., Melsept® SF, 15 min. application time at 2% concentration). The information provided by the disinfectant manufacturer on concentrations and application times must be observed.

**WARNING!**

No highly flammable disinfectants may be used! For safety reasons, spray disinfection must not be carried out, as the spray mist could penetrate the device and cause short circuits or corrosion.

If disinfectants are used that can form explosive gas mixtures, the device may only be switched on again when the gas mixtures have evaporated!

5.4 Inspection and Maintenance

**WARNING!**

No maintenance or repair work may be performed while the PROGNOST E is being used with a patient!

All maintenance and repair work may only be performed by personnel trained or authorized by PROTEC.

5.4.1 Daily Monitoring before and during the Examination Operation

Prior to operation, the operator must ensure that all safety related mechanisms, indicators and/or switches described within the user manual are fully functional and that the device is overall operationally ready.

- Check that the tabletop moves smoothly when the tabletop brake is released.
- Check the tabletop brake if it is not released.
- Check the height of the tabletop. In the case of a visible difference in height, a zero-balance adjustment must be carried out.

5.4.2 Regular Monitoring

5.4.2.1 Quality control by the operator

Quality checks for X-ray components must be performed at regular intervals in accordance with the relevant national guidelines.

5.4.2.2 Safety-related controls

In the interest of the patient, operator and external third parties, it is necessary that all checks regarding operational safety and/or functionality of the device are performed regularly every 12 months by the PROTEC customer service department, or a service provider authorized by PROTEC.

All components within the PROGNOST E, which may pose a risk due to wear and tear must be inspected and, if necessary, replaced every 12 Months by the PROTEC service department or a PROTEC authorized service provider.

In the case that the intended safety-related checks are not carried out, PROTEC X-ray Systems GmbH accepts no liability for damage to the operator and third parties if and insofar as damage results from insufficient or non-performed checks.

5.4.3 Maintenance

The required maintenance must be carried out by PROTEC service department or a service company authorized by them in order to ensure the safe and reliable functionality of the device. The maintenance intervals depend on the frequency of use. The required specifications can be found in the corresponding Technical Description in chapter 3 *Maintenance and Safety Inspection*.

In the event that the planned maintenance is not carried out, PROTEC X-ray Systems GmbH assumes no liability whatsoever for damage to the user and third parties if damage results from inadequate or not carried out maintenance.

Prior to the examination operation, the user must satisfy himself that all appliances listed in the operating instructions and serving safety are in working order and that the product is ready for operation.

See the technical descriptions of the device.

Wear parts must be replaced with original components.

5.4.4 Warranty



NOTE

You will find the current warranty conditions in your order documents or in the price list valid at the time of purchase.

Repairs and spare parts in the event of improper use are also excluded.

Warranty work may only be carried out by trained specialists.

5.4.5 Product Service Life

The PROGNOST E is designed for a service life of 10 years when used in accordance with the specifications and regular maintenance by PROTEC service department or a service company authorized by them. After the product has reached the end of its service life, further use is at your own risk.

5.4.6 Further Information

Detailed information to the individual chapters and for a safe operation, transport or storage can be found in the Technical Description of the PROGNOST E.

5.4.7 Applied Parts and Parts Considered as Applied Parts

Part	Definition
Tabletop	Applied part
Handle (optional, mounted at the tabletop)	Part, considered as an applied part
Mattress (optional)	Part, considered as an applied part

5.4.8 Disposal Notes



The PROGNOST E contains various plastics and heavy metal. When disposing exchange and spare parts, or if necessary, the entire device, the valid rules and regulations must be observed. Please contact your contractual partner or service company or commission a company specialized in disposing the respective components.

6 Power Supply



NOTE

The PROGNOST E requires the following power supply:

Power supply:	230 VAC
Power frequency:	50/60 Hz
Input current:	2,7 A



WARNING!

To avoid the risk of an electric shock, this device may only be connected to a supply network with a protective earth conductor.

6.1 Electromagnetic Compatibility (EMC) according to EN 60601-1-2



CAUTION!

As a medical electrical device, the PROGNOST E is subject to special precautionary measures regarding EMC and must be installed and commissioned in accordance with the EMC information contained in the accompanying documents.



CAUTION!

Portable RF communication devices (radio devices) should not be used closer than 30 cm (12 in) to the marked parts and cables of the PROGNOST E. Failure to observe can lead to a reduction in the performance characteristics of the device.

6.1.1 Guidelines and Manufacturer's Declaration – Electromagnetic interference

The PROGNOST E is intended for use in the electromagnetic environment specified below. The customer or the Operator of the radiographic system should assure that it is used in such an environment.

Measurement interference	Compliance	Electromagnetic Environment
RF emissions CISPR 11	Group 1	The X-ray component uses RF energy exclusively for its internal function. As a result, its RF emissions are very low and it is unlikely that nearby electronic devices will be influenced.
RF emissions CISPR 11	Class A	The device is suitable for use in facilities other than residential areas and those that are directly connected to the public supply network, which also supplies buildings that are used for residential purposes, provided the following warning is observed:
Harmonic emissions EN 61000-3-2	Class A	
Voltage fluctuations/ flicker emissions EN 61000-3-3	compliant	Warning: This device is intended for use by medical professionals only. This is a class A device according to CISPR 11. This device can cause radio interference in residential areas, in which case it must be necessary to take appropriate remedial measures such as new

		alignment, rearrangement or shielding of the device or filtering of the connection to the location.
--	--	---

Immunity Test	EN 60601-1-2 Test Level	Compliance Level	Electromagnetic Environment - Guidance
Electrostatic discharge (ESD) EN 61000-4-2	± 8 kV contact discharge ± 2 kV, ± 4 kV, ± 8 kV, ± 15 kV air discharge	± 8 kV contact discharge ± 2 kV, ± 4 kV, ± 8 kV, ± 15 kV air discharge	Floors should be made of wood, concrete or ceramic tiles. If the floor is covered with synthetic material, the relative humidity must be at least 30%.
Fast transient electrical disturbance variables / burst EN 61000-4-4	± 2 kV for power supply lines ± 1 kV for input/output lines	± 2 kV for power supply lines ± 1 kV for input/output lines	The quality of the supply voltage should correspond to that of a typical business or hospital environment.
Surges EN 61000-4-5	± 0,5 kV ± 1 kV ± 2 kV	± 0,5 kV ± 1 kV ± 2 kV	The quality of the supply voltage should be that of a typical commercial or hospital environment.
Magnetic field at the supply frequency (50/60 Hz) EN 61000-4-8	30 A/m 50/60 Hz	30 A/m 50/60 Hz	Magnetic fields at the mains frequency should correspond to the typical values found in a business and hospital environment.
Voltage dips, short interruptions and fluctuations in the supply voltage EN 61000-4-11	<5 % UT (>95 % dip in UT) for ½ cycle <5 % UT (>95 % dip in UT) for 1 cycle 70 % UT (30 % dip in UT) for 25/30 cycles <5 % UT (>95 % dip in UT) for 5/6s	<5 % UT (>95 % dip in UT) for ½ cycle <5 % UT (>95 % dip in UT) for 1 cycle 70 % UT (30 % dip in UT) for 25/30 cycles <5 % UT (>95 % dip in UT) for 5/6s	The quality of the supply voltage should correspond to that of a typical business or hospital environment. If the user of the device demands continued operation even if there are interruptions in the energy supply, it is recommended that the device be fed from an uninterruptible power supply or battery.
Conducted disturbances induced by RF fields EN 61000-4-6	3 V/m 1 kHz 80% AM 150 kHz bis 80 MHz	3 V/m	
Radiated RF disturbances EN 61000-4-3	3 V/m 1kHz 80% AM 80 MHz to 2.7 GHz	3 V/m	See table below

NOTE: These guidelines may not apply in all situations. Electromagnetic propagation is affected by absorption and reflection from structure, objects and people.

Test Frequency in MHz	Frequency Band in MHz	Service in MHz	Modulation	Immunity Testing Level in V/m
385	380 - 390	TETRA 400	Pulse modulation: 18 Hz	27
450	430 – 470	GMRS 460, FRS 480	FM ±5 kHz Deviation 1 kHz Sine	28
710 745 780	704 – 787	LTE Band 13, 17	Pulse modulation: 217 Hz	9
810 870 930	800 – 960	GSM 800/900, TETRA 800, iDEN 820, CDMA 850, LTE Band 5	Pulse modulation: 18 Hz	28
1720 1845 1970	1700 - 1990	GSM 1800, CDMA 1900, GSM 1900, DECT, LTE Band 1, 3, 4, 25, UMTS	Pulse modulation: 217 Hz	28
2450	2400 – 2570	Bluetooth, WLAN, 802.11 b/g/n, RFID 2450, LTE Band 7	Pulse modulation: 217 Hz	28
5240 5500 5785	5100 - 5800	WLAN, 802.11 a/n	Pulse modulation: 217 Hz	9

7 Technical Data

7.1 Dimensions

**100kg TP Carbon
220 POUNDS TP CARBON
75 kg TP Verbundstoff 2m
165 POUNDS TP COMPOSITE FIBRE 2m
65 kg TP Verbundstoff 2,26m
132 POUNDS TP COMPOSITE FIBRE 2,26m

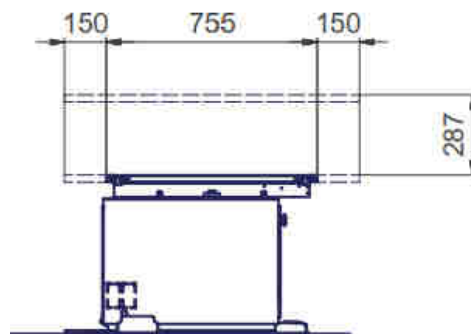
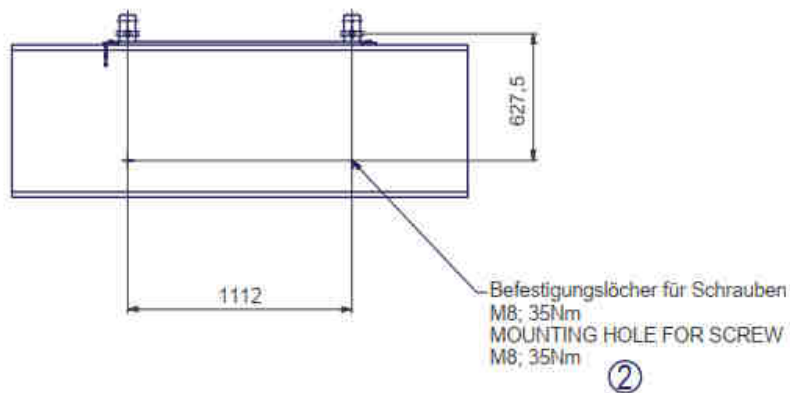
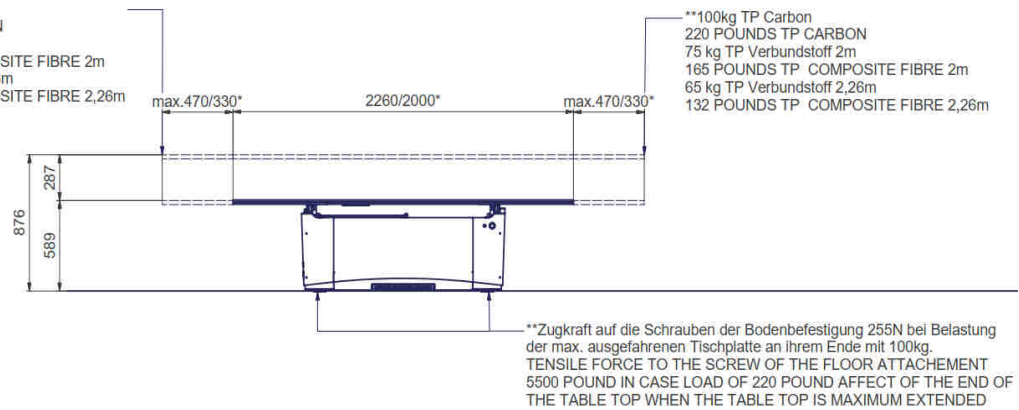

Tabletop dimensions (L x W):

226 cm x 75.5 cm or
200 cm x 75,5 cm

Max. Patient weight (line load)

230 kg (standard)
250 kg (High speed)

Table height:

589mm - 876 mm (standard)

Tabletop transverse displacement (from the centre position):

± 150 mm

Longitudinal displacement of the tabletop (from the centre position):

± 330 mm (200 cm tabletop)

Longitudinal displacement of the tabletop (from the centre position):

± 470 mm (226 cm tabletop)

The brakes of the tabletop are actuated electromechanically.

7.2 Attenuation Equivalent



CAUTION!

The attenuation equivalent of the PROGNOST E may have to be considered during the acceptance test of the X-ray system.

The tabletop is defined as an applied part.

The aluminium attenuation equivalent of the tabletop is typically 0.7 mm Al and <0.8 mm Al for carbon; 0.85 mm Al for composite material according to EN 60601-1-3 at 100 kV and a first half-value layer thickness of 3.6 mm Al and typically 0.6 mm Al and <0.8 mm Al according to 21CFR § 1020.30 (m) at 100 kV and a first half-value layer thickness of 3.6 mm Al.

7.2.1 Protection Type and Protection Class

The PROGNOST E corresponds to protection class 1 and contains applied parts type B (according to EN 60601-1).

7.3 Environmental Conditions

7.3.1 Environmental Conditions during Operation











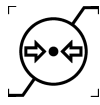

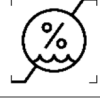

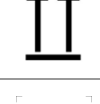
Ambient Temperature	+ 10°C to + 40°C
Relative humidity	30% to 75% (non-condensing)
Atmospheric pressure	700 hPa to 1060hPa

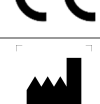

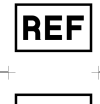

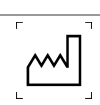



7.3.2 Environmental Conditions for Shipping and Storage

Ambient Temperature	- 10°C to + 70°C
Relative humidity	10% to 95% (non-condensing)
Atmospheric pressure	500 hPa to 1060hPa

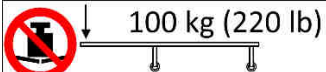

8 Description of Symbols, Labels and Abbreviations

8.1 Symbols

	Atmospheric pressure limit
	Temperature limit
	Humidity limit
	Keep dry
	Fragile, handle with care
	This way up
	Attention, observe accompanying documents
	Refer to Instructions for use
	CE marking
	Manufacturer
	Medical Device
	Order reference
	Serial number
	Unique Device Identification
	Production date
	Classification according to EN 60601-1 (type B applied part)
	Caution: pinch-/crushing hazard for hands and fingers

 www.protec-med.com/download	This symbol indicates the need to observe the instructions for use. This is provided in an electronic format (eIFU) on our website.
	Disposal instructions; WEEE (Waste of Electrical and Electronic Equipment)
	Protective earthing
	Do not exceed the maximum indicated weight
	Do not exceed the maximum indicated weight
	Table height adjustment – table up
	Table height adjustment – table down
	Release tabletop brakes

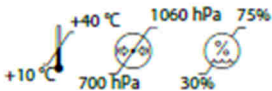

8.2 Type Label

<table border="1" style="width: 100%; border-collapse: collapse;"> <tr><td style="padding: 2px;">MD</td></tr> <tr><td style="padding: 2px;">REF</td></tr> <tr><td style="padding: 2px;">SN</td></tr> </table> <p>7043-5-8701</p> <p>SNxxxxxx</p> <p>2025-07-09</p> <p>www.protec-med.com/download</p>	MD	REF	SN	<p>PROGNOST E</p> <p>Basic diagnostic X-ray system table, powered</p> <p>POWER RATING</p> <table border="1" style="width: 100%; border-collapse: collapse;"> <tr><td style="text-align: center;">230</td><td style="text-align: center;">V ~</td></tr> <tr><td style="text-align: center;">50</td><td style="text-align: center;">Hz</td></tr> <tr><td style="text-align: center;">2.7</td><td style="text-align: center;">A</td></tr> </table> <p style="text-align: center; font-size: 2em;">CE</p>	230	V ~	50	Hz	2.7	A	 <p>PROTEC X-ray Systems GmbH In den Dorfwiesen 14 71720 Oberstenfeld Germany</p> <div style="display: flex; align-items: center;">  <div style="text-align: left;"> <p>(01)04260502641842</p> <p>(11)250709</p> <p>(21)SNxxxxxx</p> </div> </div> <p style="writing-mode: vertical-rl; transform: rotate(180deg); font-size: 0.8em;">TL.7043-5-8701V04</p>
MD											
REF											
SN											
230	V ~										
50	Hz										
2.7	A										



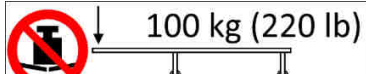
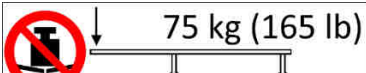

8.3 Labels

Labels on the front side of the different tabletops

	Carbon fibre tabletop
	Composite fibre tabletop 200cm
	Composite fibre tabletop 226cm

Labels on the tabletop

	Caution: Watch out for possible crushing hazards to fingers or hands while moving the tabletop, table or X-ray unit.
 230kg 506lb	Maximum allowed patient weight (distributed load) for the tabletop (Composite fibre tabletop).
 250kg 550lb	Maximum allowed patient weight (distributed load) for the tabletop (Carbon tabletop).

Labels on the front plate



Company label

8.4 Positions of the Signs and Labels



8.5 Abbreviations

mm	Millimetre
cm	Centimetre
lb.	Pound
kg	Kilogram
°C	Degree -Celsius
hPa	Hectopascal
DIN	German Industry Standard
EN	European Standard
CE	CE-Mark
Hz	Hertz
ED	Duty cycle
A	Ampere
SN	Serial number
V AC	Volt (alternating current)
V DC	Volt (direct current)
inch	Inches