

PROGNOST SH

X-ray system tube support, floor stand

Model/ID: 7040-5-xxxx
Basic UDI-DI: 426050264X016ZQ

Instructions for use

ID No. 5040-0-8002



PROGNOST SH in analogue base configuration



**The PROGNOST SH does not include any X-ray components (X-ray tube, collimator, X-ray generator)*



**NOTE**

All sheets of this document contain proprietary and confidential information of PROTEC X-ray Systems GmbH and is intended for exclusive use by current PROTEC X-ray Systems GmbH customers. Copying, disclosure to others or other use is prohibited without the express written consent of PROTEC's law department. Knowledge of violations of these regulations must be reported immediately to PROTEC X-ray Systems GmbH.

© 2025 PROTEC X-ray Systems GmbH, Oberstenfeld

Comments and questions about the documentation, please contact:

PROTEC X-ray Systems GmbH

In den Dorfwiesen 14 | 71720 Oberstenfeld
Germany

Phone: (+ 49) 7062 – 92 55 0

Fax: (+ 49) 7062 – 92 55 60

E-Mail: protec@protec-med.com

Internet: www.protec-med.com

Table of contents

	Page
Table of contents	3
Revision Status	5
General Notes	6
Mechanical and Electric Warning	6
To the User	6
1 Device Description	7
1.1 Introduction	7
1.2 Description.....	7
1.2.1 Versions	7
1.2.2 Hardware and Network System Requirements	7
1.2.3 Installation	8
1.2.3.1 Floor Loading Capacity.....	8
1.3 Performance Characteristics	8
1.3.1 X-ray system tube support, floor stand	8
1.4 Intended Use	9
1.5 Clinical Benefit	9
1.6 Patient Target Group(s).....	9
1.7 Medical Conditions to be diagnosed	9
1.8 Indications and Contraindications	9
1.9 Intended User Group.....	9
1.10 Declaration of Conformity.....	9
2 Safety Instructions	10
2.1 General Safety Instructions.....	11
2.1.1 Requirements for operation	11
2.1.2 Device Operation	11
2.1.2.1 Operating Type	11
2.1.3 Operating Personnel	11
2.1.4 Crushing and Collision Hazard	11
2.1.5 Explosion Protection	11
2.1.6 Interaction with Other Devices.....	11
2.1.7 Electromagnetic Environment and Influencing of Devices	12
3 Control Elements and Displays	13
3.1 Main Switch of the PROGNOST SH	13
3.2 Emergency Stop Switches of the PROGNOST SH.....	13
3.3 Control Elements and Display of the PROGNOST SH.....	13
3.3.1 X-ray system tube support, floor stand	13
3.3.2 Operating Unit PROGNOST SH	14
3.3.3 Operating Unit PROGNOST SH TOUCH	15
3.3.4 Foot pedal.....	16
4 Handling	17
4.1 Operation of the PROGNOST SH	17
4.2 Function of the PROGNOST SH.....	17
4.2.1 Switching the PROGNOST SH on and off.....	17
5 Safety and Maintenance	18
5.1 Introduction	18
5.2 Reusability	18
5.3 Cleaning and Disinfection	18
5.3.1 Cleaning.....	18
5.3.2 Disinfection.....	18
5.4 Inspection and Maintenance.....	19
5.4.1 Daily Monitoring before and during the Examination Operation.....	19
5.4.2 Regular Monitoring	19

5.4.2.1	Quality control by the operator	19
5.4.2.2	Safety-related controls.....	19
5.4.3	Maintenance	19
5.4.4	Warranty.....	20
5.4.5	Product Service Life	20
5.4.6	Further Information	20
5.4.7	Applied Parts and Parts Considered as Applied Parts.....	20
5.4.8	Disposal Notes	20
6	Power Supply	21
6.1	Electromagnetic Compatibility (EMC) according to EN 60601-1-2	21
6.1.1	Guidelines and Manufacturer's Declaration – Electromagnetic interference.....	21
7	Technical Data.....	24
7.1	Dimensions.....	24
7.1.1	Traveling Distances	25
7.1.2	Total Weight	25
7.1.3	Protection Type and Protection Class	26
7.2	Environmental Conditions	26
7.2.1	Environmental Conditions during Operation.....	26
7.2.2	Environmental Conditions for Shipping and Storage	26
8	Description of Symbols, Labels and Abbreviations	27
8.1	Symbols	27
8.2	Type Label	28
8.3	Labels	28
8.4	Positions of the Signs and Labels.....	29
8.5	Abbreviations	29

**NOTE**

The information contained in this document conforms to the configuration of the equipment as of the date of manufacture. Revisions to the equipment subsequent to the date of manufacture will be addressed in service updates distributed to the PROTEC Technical Service Organisation.

Revision Status

Revision	Date	Updated pages	Comments	Author
1.0	2019-05-14	all	Newly created. Replace document 5040-0-0002_Rev01	
2.0	2019-08-02	Chap. 1.2.1, 1.2.2.1, 2.1.2, 6.1.1, 7.1.2, 8.1, 8.2	changed content, changed weight, Adaption of the intended use and GMDN term throughout the document EMC-tables removed Added symbols Identification label updated	
3.0	2020-06-17	Chap. 1.2, 3.2, 3.2, 4.1, 7.1	Telescopic arm added	
4.0	2020-08-11	Front page, Chap. 5.3.3	Maintenance updated	
5.0	2020-20-11	Chap. 1.2.1, 1.2.2.1, 1.3.2, 3.1, 3.2.1-3.2.3, 7.1.1, 7.1.2, Chap. 4.2.1 Front page	Rotatable X-ray column added Attention by stating TOUCH-display added Model ID revised	
6.0	2021-05-25	all	V5.0 transferred to new Layout (MDR)	MB
7.0	2022-01-20	Chap. 1.2.1 Chap. 1.3 Chap. 7.1 Chap. 7.1.1 Chap. 7.1.2	Versions revised Performance characteristics revised Dimensions updated Traveling distances updated Total weight updated	MB
8.0	2023-04-12	Chap. 1.2.1, 1.3.1, 4.1, 8,1	Electrical release for rotating the X-ray tube stand added	TB
9.0	2023-07-12	List 7.1.1; Chap. 8.2; page 10	Traveling distance long floor rails new; typelabel; FB-04-07A4.3	ML
10.0	2024-04-03	Chap. 1.2.1	Base plate for free-standing floor installation deleted.	ML
11.0	2024-04-12	Chap. 7.1.1	Traveling distance for angulation around horizontal tube column added	TB
12.0	2025-07-16	All	First edition PROTEC X-ray System GmbH	ML

General Notes



WARNING!

In order to maintain the set and tested requirements of the 60601 series of standards, the ME system must not be modified during its actual operating life.

Mechanical and Electric Warning



WARNING!

All of the movable assemblies and parts of this equipment should be operated with care and routinely inspected in accordance with the manufacturer's recommendations contained in the equipment accompanying documents. Maintenance and service is only to be performed by customers authorized by PROTEC X-ray Systems GmbH.

Live electrical terminals are deadly.

Do not remove flexible high-tension cables from X-ray tube cover or high-tension generator and/or access covers from X-ray generator.

For all components of the equipment protective earthing means must be provided in compliance with the national regulations.

Failure to comply with the foregoing may result in serious or fatal bodily injuries to the operator or those in the area.

To the User



NOTE

The user of these accompanying documents is required to carefully read through and carefully consider the instructions, warnings and cautions contained therein before starting operation.

Even if you have already operated similar systems, changes in the design, production and functional routine of the system described here may have been made, which have a significant influence on the operation.

Assembly and service works on the system described here must be carried out by authorised and qualified personnel from PROTEC X-ray Systems GmbH. Assembly personnel and other persons who are not employees of the technical service department of PROTEC X-ray Systems GmbH are requested to contact the local branch of PROTEC X-ray Systems GmbH before assembly or service work is started. For assembly and service works, it is necessary to use the "Technical Description" of the product and to observe the points it contains.



NOTE

The use of the product with add-on or accessory parts not authorized by PROTEC or other unapproved components is not permitted.



NOTE

According to Regulation (EU) 2017/745 of medical devices, all serious incidents related to the device must be reported to the manufacturer and the responsible authority of the Member State where the user and/or the patient is established.

1 Device Description

1.1 Introduction

The instructions for use describe the performance characteristics and operation required for efficient and effective use of the PROGNOST SH.

Before you work with the PROGNOST SH, the complete instructions for use must be read, especially the Safety Instructions and the chapter Handling.

1.2 Description

The X-ray tube support stand PROGNOST SH is guided on two floor-fixed rails. For special applications it is also possible to fix the X-ray tube support stand directly to the floor.

The X-ray tube arm is prepared for the installation of an X-ray tube assembly (X-ray tube with collimator) and the control unit.

All movements of the tube stand and X-ray tube assembly are smooth and locked by electromagnetic brakes. Additionally, the rotation of the X-ray tube assembly around the horizontal support arm axis has pre-defined stops at 90°, e.g., for proper alignment with a Bucky wall stand.

The control elements are easily accessible from the front.

1.2.1 Versions

PROGNOST SH 6AS; Angle display 6 buttons, standard	7040-5-80xx
PROGNOST SH 6T; TOUCH 6 buttons, standard	7040-5-90xx
PROGNOST SH 7AS; Angle display 7 buttons, telescopic	7040-5-85xx
PROGNOST SH 7T; TOUCH 8 buttons, telescopic	7040-5-95xx
PROGNOST SH 6AS; Angle display 6 buttons, column rotation	7040-5-8600
PROGNOST SH 6T; TOUCH 6 buttons, column rotation	7040-5-9600
PROGNOST SH 7AS; Angle display 7 buttons, column rotation, electr.unlocked	7040-5-8650
PROGNOST SH 7T; TOUCH 7 buttons, column rotation, electr.unlocked	7040-5-9650
PROGNOST SH 7AS; Angle display 7 buttons, telescopic, column rotation	7040-5-8700
PROGNOST SH 7T; TOUCH 7 buttons, telescopic, column rotation	7040-5-9700
PROGNOST SH 8AS; Angle display 8 buttons, telescopic, column rotation, electr.unlocked	7040-5-8750
PROGNOST SH 8T; TOUCH 8 buttons, telescopic, column rotation, electr.unlocked	7040-5-9750

Optional Components

- Collimator
- X-ray tube
- X-ray generator

Optional Accessories

- Floor rail extension short
- Floor rail extension long
- Control unit with Touch-Display
- Base plate in conjunction with wall installation
- Telescopic function tube arm (+230mm)
- Rotatable X-ray tube support stand by $\pm 180^\circ$
- Electrical release for rotating the X-ray tube stand by $\pm 180^\circ$

Accessories that can influence the EMC conditions

- Network cable (take note of the max. cable length in the component documents)

1.2.2 Hardware and Network System Requirements

As a stand-alone product, the analogue version of the PROGNOST SH has no hardware or network connection and therefore no hardware or network requirements.

If the X-ray tube support stand PROGNOST SH is the version with integrated Tablet-PC for digital use, it should be ensured that the country specific requirements for data protection and IT security are met.

1.2.3 Installation



NOTE

The installation of the PROGNOST SH must be performed by PROTEC service department or a service company authorized by them.

For more information, please see separate "Installation manual PROGNOST SH".

Contact information of persons qualified to perform installations are available upon request at:

PROTEC X-ray Systems GmbH

In den Dorfwiesen 14 | 71720 Oberstenfeld

Germany

Phone: (+ 49) 7062 – 92 55 0

Fax: (+ 49) 7062 – 92 55 60

E-Mail: protec@protec-med.com

Internet: www.protec-med.com

1.2.3.1 Floor Loading Capacity



NOTE

The PROGNOST SH is primarily made of metal pieces. This has a corresponding effect in the weight of the device.

The PROGNOST SH has a weight of max. 410 kg.

Every technician is obliged to check the ground load. Raised floors and hollow floors must also be considered.

1.3 Performance Characteristics

1.3.1 X-ray system tube support, floor stand

- Ceiling independent tube stand suitable for rooms with minimum 2.35 m ceiling height/standard and 2.40 m ceiling height/rotation tube column
- Wide range of application
- Short Installation time
- High reliability
- Short wall distance allows an optimal utilization of available space
- Control elements of the control unit are arranged for easy access from the front
- Angle indicator ensures reproducible position of X-ray tube assembly when rotating around the tube arm axis
- Vertical travelling range, focus height from 29.7 cm to 189.6 cm with horizontal beam path
- Electromagnetic brakes for horizontal travel of the tube stand and vertical travel of the X-ray tube assembly.
- Electromagnetic brakes for transversal travel of the support arm (optional)
- Foot pedal for rotation of the X-ray tube assembly around the support arm axis, with additional 90° click-stops (optional)
- Electrical release for rotation of the X-ray tube stand around the X-ray arm axis with additional 90° detents (optional)

1.4 Intended Use

The PROGNOST SH X-ray tube support stand is intended to be used as an electronically controlled component of a diagnostic X-ray system to mount, support and facilitate positioning of an X-ray tube assembly (not included) for various routine applications in planar X-ray imaging in human medicine.

1.5 Clinical Benefit

Considered in isolation, no clinical benefit can be shown for X-ray tube support stands.

As components of diagnostic X-ray systems in human medicine, they contribute to the clinical benefit of X-ray systems, which consists of the generation of conventional two-dimensional X-ray images for creation or specification of findings as a basis for treatment decisions.

1.6 Patient Target Group(s)

The intended patient group includes all people for whom a justifying indication for a medical X-ray has been given by a physician with the necessary expertise in radiation protection.

There are no general or fundamental restrictions on the patient group regarding age, gender, origin and patient condition.

1.7 Medical Conditions to be diagnosed

As standalone products, X-ray tube support stands, have no function to diagnose, treat and/or monitor medical conditions.

1.8 Indications and Contraindications

As standalone products, X-ray tube support stands have no intended main effect in or at the human body. Therefore, considered in isolation, no indications or contraindications can be shown for them.

1.9 Intended User Group

As a component of a diagnostic X-ray system, PROGNOST SH is intended exclusively for use by professional users who are trained in the operation of diagnostic X-ray systems in accordance with the respective national regulations and who are familiar with the proper handling, use and operation and also have been instructed in the permitted conjunction with other medical products, objects and accessories.

Appropriate users can be, for example: X-ray technicians, X-ray assistants, medical technical X-ray assistants, surgeons, casualty surgeons, orthopaedists and other trained medical personnel.

1.10 Declaration of Conformity



This product complies with the requirements of Regulation (EU) 2017/745 of the European Parliament and of the Council of 5 April 2017 on medical devices, including all applicable corrigenda.

The declaration of conformity is available upon request from PROTEC:

PROTEC X-ray Systems GmbH

In den Dorfwiesen 14 | 71720 Oberstenfeld
Germany

Phone: (+ 49) 7062 – 92 55 0

Fax: (+ 49) 7062 – 92 55 60

E-Mail: protec@protec-med.com

Internet: www.protec-med.com

2 Safety Instructions



NOTE

Contains information that must be observed during operation.

xxx



CAUTION!

Contains information which, if not observed, can cause property damage.

xxx



WARNING!

Contains information which, if not followed, can cause personal injury.

xxx



WARNING!

Warning of radioactive substances or ionizing radiation. Contains information which, if not observed, can cause personal injury.

xxx

Settings and calibrations that are not described in these instructions for use must be carried out using the technical description of the device by PROTEC service department or a service company authorized by them.



NOTE

All instructions supplied with the PROGNOST SH must be observed and the safety instructions contained therein must be carefully read and adhered to.



NOTE

After the initial installation, the commissioning must be recorded with the PROTEC acceptance protocol FB-04-07A4.3.



NOTE

The PROGNOST SH may only be commissioned if all safety measures for operator protection have been met and checked. These protective measures can include door contact, designated area, dosimeter, protective clothing, etc.



CAUTION!

The instructions for use contain all the information relevant to safety in order to generally put the PROGNOST SH into operation. The device may only be operated by appropriately trained and trained personnel. In this context, operation is ensured by clear symbols on the control elements. All further information and instructions can be found on the supplied data carrier (USB, CD or DVD). This information applies in its entirety as an appendix to these instructions for use and must be observed.



NOTE

All control elements are described again in detail in these operating instructions.

2.1 General Safety Instructions

2.1.1 Requirements for operation



WARNING!

The PROGNOST SH is a protection class I device (according to EN 60601-1). To avoid the risk of an electric shock, this device may only be connected to a supply network with a protective earthing conductor.

The power supply for the PROGNOST SH of the X-ray system is exclusively made by direct connection to the X-ray generator or the Power Box and is permanently connected there. The X-ray generator or the Power Box must have at least 2 connections for 230V 50/60Hz.

The X-ray generator of the X-ray system is connected to the supply network (see technical description of the X-ray generator).

To reduce the risk of electric shock, the system must be connected to a supply network with protective earthing.

The system does not have an on/off switch. It is switched on or off directly by switching on the X-ray generator or by the switch on the Power Box. In order to separate any electrical voltage from the X-ray system, the connected X-ray generator or the Power Box must be switched off.

2.1.2 Device Operation

In case of a malfunction, do not use the PROGNOST SH anymore and notify PROTEC service department or a service company authorized by them.

2.1.2.1 Operating Type

The PROGNOST SH is not intended for continuous operation.

2.1.3 Operating Personnel



NOTE

Only trained and authorized personnel are allowed to work on the PROGNOST SH.



NOTE

The operating personnel must be familiar with all warning signs attached to the PROGNOST SH. They are used for your own safety and that of others and ensure proper operation.

2.1.4 Crushing and Collision Hazard



WARNING!

It must be ensured that when operating the moving parts of PROGNOST SH, no persons or objects are in the obvious danger area of the device. If not observed, it can result in personal injury or damage to the PROGNOST SH or other objects.

2.1.5 Explosion Protection

The PROGNOST SH is not designated for use within areas with explosive hazards.

2.1.6 Interaction with Other Devices

Interactions with other devices are not known.

2.1.7 Electromagnetic Environment and Influencing of Devices



CAUTION!

The use of other accessories, other converters and other cables than those specified by PROTEC or provided in the documentation of the component manufacturer can result in increased electromagnetic interference or reduced electromagnetic immunity of the device and lead to defective operation.



CAUTION!

The use of the PROGNOST SH immediately next to other devices or with other devices in a stacked form should be avoided, as this could result in defective operation. If use in the manner described above is nevertheless necessary, the PROGNOST SH and the other devices should be observed to ensure that they are working properly.



NOTE

The properties of this device, determined by emissions, allow its use in industrial areas and in hospitals (CISPR 11, class A). When used in residential areas (for which class B is usually required by CISPR 11), this device may not provide adequate protection for radio services. The user may need to take remedial measures such as relocating or realigning the device.

The PROGNOST SH is intended for use in an environment in professional health care facilities (e.g., clinics, surgery centres, physiology practices ...).

3 Control Elements and Displays

3.1 Main Switch of the PROGNOST SH

The PROGNOST SH does not have a main switch.

3.2 Emergency Stop Switches of the PROGNOST SH

The PROGNOST SH does not have emergency stop switches.

3.3 Control Elements and Display of the PROGNOST SH

3.3.1 X-ray system tube support, floor stand

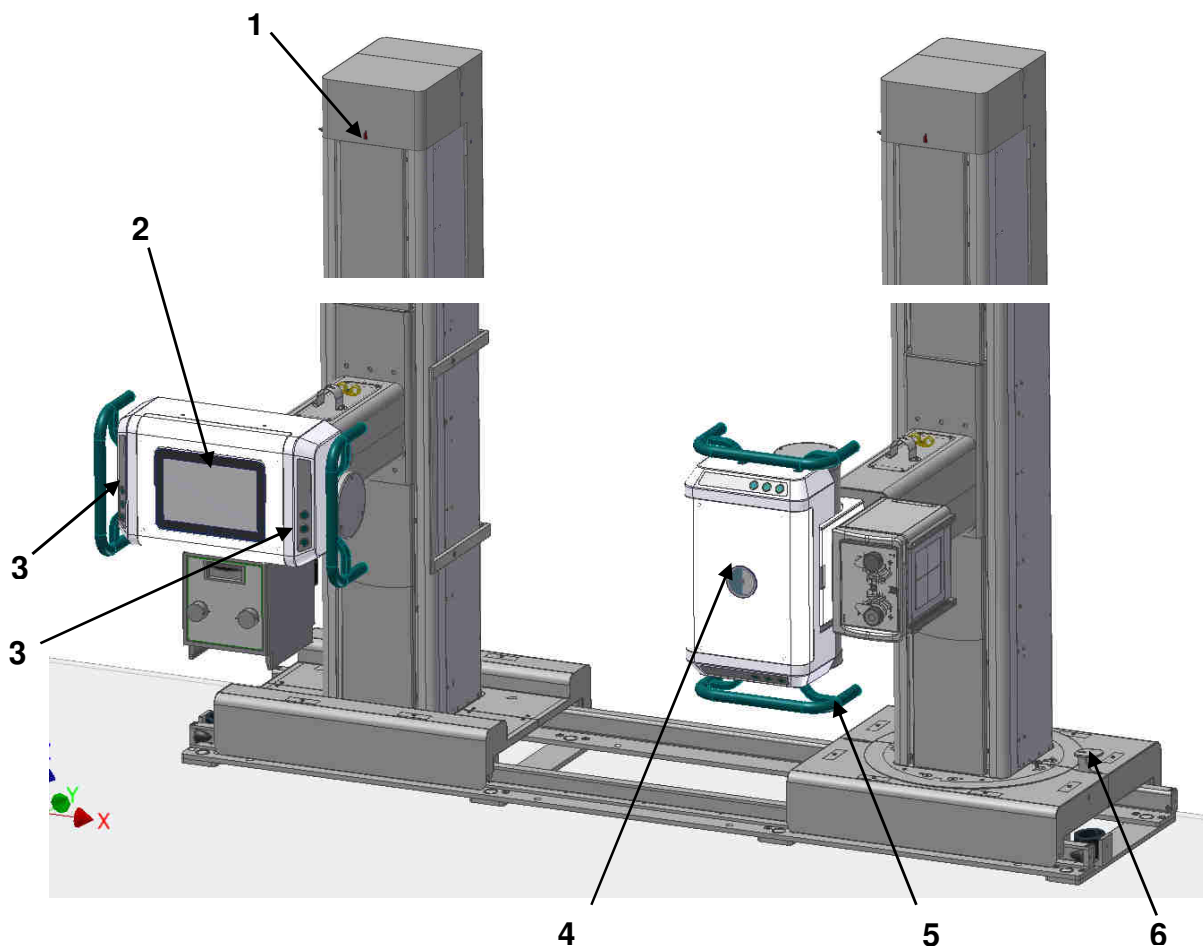

- 1 Indication of rope breakage
- 2 Operating unit with Touch-Display
- 3 Keypad
- 4 Operating unit with inclinometer
- 5 Handle
- 6 Foot pedal

3.3.2 Operating Unit PROGNOST SH

- 1 Angle indicator for adjusting the X-ray tube assembly
- 2 Horizontal movement of the X-ray floor stand
- 3 Rotational movement of the X-ray unit around the horizontal tube arm axis
- 4 Horizontal movement of X-ray floor stand and vertical movement of X-ray tube arm
- 5 Horizontal movement of X-ray floor stand and vertical movement of X-ray tube arm
- 6 Rotational movement of the X-ray unit around the horizontal tube arm axis
- 7 Vertical movement of the X-ray tube arm
- 8 Optional: Transversal movement of the X-ray tube arm (+230mm)
- 9 Optional: Status-LED orange (if LED is on: X-ray tube arm is not engaged)
- 10 Optional: Status-LED red (if LED on: X-ray floor stand is not engaged)
- 11 Optional: Electrical release for rotating the X-ray floor stand by $\pm 180^\circ$



WARNING!

If the red LED on the right keypad lights up, the X-ray tube arm is not engaged! No X-ray exposures may be performed in this state. The X-ray tube arm must first engage in one of the positions ($0 / \pm 90^\circ / \pm 180^\circ$)!

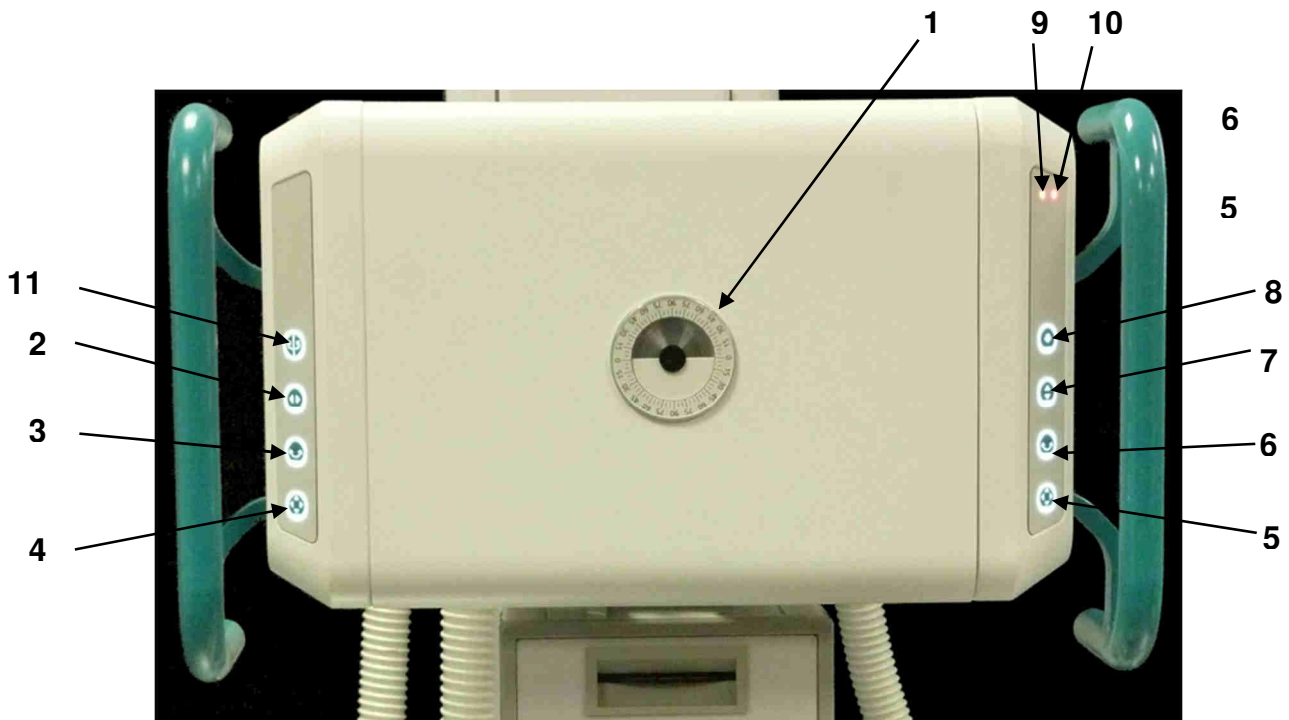

The operation is performed from the front (operating side) of the operating unit.

While comprising the handles, the electromagnetic locking of one or more movements can be released by pressing the buttons on the operating unit with the thumb, and the X-ray tube unit can be brought into the desired position.

3.3.3 Operating Unit PROGNOST SH TOUCH

- 1 Touch-Display of the operating unit
- 2 Horizontal movement of the X-ray floor stand
- 3 Rotational movement of the X-ray unit around the horizontal tube arm axis
- 4 Horizontal movement of X-ray floor stand and vertical movement of X-ray tube arm
- 5 Horizontal movement of X-ray floor stand and vertical movement of X-ray tube arm
- 6 Rotational movement of the X-ray unit around the horizontal tube arm axis
- 7 Vertical movement of the X-ray tube arm
- 8 Optional: Transversal movement of the X-ray tube arm (+230mm)
- 9 Optional: Status-LED orange (if LED is on: X-ray tube arm is not engaged)
- 10 Optional: Status-LED red (if LED on: X-ray floor stand is not engaged)
- 11 Optional: Electrical release for rotating the X-ray floor stand by $\pm 180^\circ$



WARNING!

If the red LED on the right keypad lights up, the X-ray tube arm is not engaged! No X-ray exposures may be performed in this state. The X-ray tube arm must first engage in one of the positions ($0 / \pm 90^\circ / \pm 180^\circ$)!

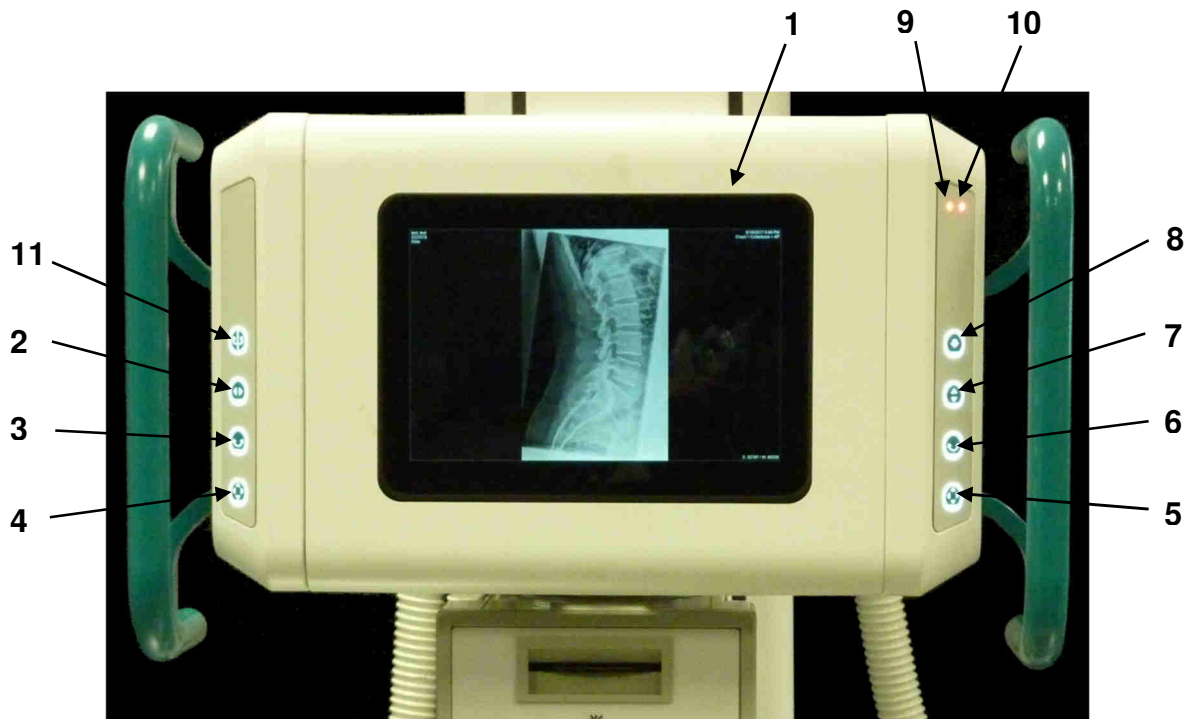

The operation is performed from the front (operating side) of the operating unit.

While comprising the handles, the electromagnetic locking of one or more movements can be released by pressing the buttons on the operating unit with the thumb, and the X-ray tube unit can be brought into the desired position.

3.3.4 Foot pedal

To unlock the X-ray floor stand, the foot pedal (1) must be actuated downwards. Hold the foot pedal in this position and turn the X-ray floor stand slightly in the desired direction. The foot pedal does not have to be actuated for further rotation. The detent in the new position centers itself.



WARNING!







There is an increased risk of injury if the X-ray floor stand is not engaged!



4 Handling

4.1 Operation of the PROGNOST SH

Both handles of the X-ray tube assembly are gripped with the hands and the button for the respective movement is pressed with the thumbs. This releases the respective brake and the X-ray tube assembly can be moved manually to the desired position.

	Horizontal movement of the X-ray tube stand
	Vertical movement of the X-ray tube arm
	Rotation of the X-ray tube assembly
	Horizontal movement of the X-ray tube stand and vertical movement of the X-ray tube arm
	Transversal movement of the X-ray tube arm (optional)
	Electrical release for rotating the X-ray tube stand by $\pm 180^\circ$ (optional)

4.2 Function of the PROGNOST SH

4.2.1 Switching the PROGNOST SH on and off

The PROGNOST SH starts with applying of a power supply and is not started separately.



ATTENTION!

Special feature for the Touch option: The system is only switched off if the Touch-Display is completely shut down. Do not restart the system until the Touch-Display is completely shut down. Otherwise, the Touch-Display does not start.

5 Safety and Maintenance



WARNING!

Caution, risk of electric shock!

Switch off the PROGNOST SH before cleaning or disinfecting. This disconnects the PROGNOST SH from the power source and avoids the risk of electric shock.

5.1 Introduction

In this chapter you will find information about safety and maintenance that are necessary to ensure the correct and reliable function of the device after installation.

5.2 Reusability

The PROGNOST SH can be reused without any special preparation procedures.

The PROGNOST SH must no longer be used with patients if it shows signs of wear (e.g., metal abrasion, wear of insulations) or dangerous technical defects (e.g., torn cable, bent parts) or if the resulting image quality (e.g., artifacts in the image) is insufficient.

In this case, please contact the PROTEC service department or a service company authorized by them immediately.

5.3 Cleaning and Disinfection



NOTE

Caution
Possible material changes!



WARNING!

Make sure that no liquid enters the interior of the housing during cleaning and disinfection in order to prevent electrical short circuits and/or corrosion.

5.3.1 Cleaning

The cleaning of the PROGNOST SH is very easy due to the very good quality surface coating. This is usually only done with a dry cloth.

Do not use corrosive, dissolving or abrasive cleaning agents, which could damage the device surfaces or the coating.

Clean the device surfaces and painted parts with a damp cloth and a mild to slightly alkaline cleaning solution (e.g., RBS® Neutral T) and wipe dry.

Chrome parts may only be wiped with a dry woollen cloth.

5.3.2 Disinfection

The disinfection must be performed in accordance with the current applicable legal requirements and guidelines corresponding for disinfection and explosion protection.

All mechanical parts of the PROGNOST SH, including accessories, may only be cleaned with a wipe disinfection with suitable surface disinfectants (e.g., Melsept® SF, 15 min. application time at 2% concentration). The information provided by the disinfectant manufacturer on concentrations and application times must be observed.

**WARNING!**

No highly flammable disinfectants may be used! For safety reasons, spray disinfection must not be carried out, as the spray mist could penetrate the device and cause short circuits or corrosion.

If disinfectants are used that can form explosive gas mixtures, the device may only be switched on again when the gas mixtures have evaporated!

5.4 Inspection and Maintenance

**WARNING!**

No maintenance or repair work may be performed while the PROGNOST SH is being used with a patient!

All maintenance and repair work may only be performed by personnel trained or authorized by PROTEC.

5.4.1 Daily Monitoring before and during the Examination Operation

Prior to operation, the operator must ensure that all safety related mechanisms, indicators and/or switches described within the user manual are fully functional and that the device is overall operationally ready.

5.4.2 Regular Monitoring

5.4.2.1 Quality control by the operator

Quality checks for X-ray components must be performed at regular intervals in accordance with the relevant national guidelines.

5.4.2.2 Safety-related controls

In the interest of the patient, operator and external third parties, it is necessary that all checks regarding operational safety and/or functionality of the device are performed regularly every 12 months by the PROTEC customer service department, or a service provider authorized by PROTEC.

All components within the PROGNOST SH, which may pose a risk due to wear and tear must be inspected and, if necessary, replaced every 12 Months by the PROTEC service department or a PROTEC authorized service provider.

In the case that the intended safety-related checks are not carried out, PROTEC X-ray Systems GmbH accepts no liability for damage to the operator and third parties if and insofar as damage results from insufficient or non-performed checks.

5.4.3 Maintenance

The required maintenance must be carried out by PROTEC service department or a service company authorized by them in order to ensure the safe and reliable functionality of the device. The maintenance intervals depend on the frequency of use. The required specifications can be found in the corresponding Technical Description in chapter 3 *Maintenance and Safety Inspection*.

In the event that the planned maintenance is not carried out, PROTEC X-ray Systems GmbH assumes no liability whatsoever for damage to the user and third parties if damage results from inadequate or not carried out maintenance.

Prior to the examination operation, the user must satisfy himself that all appliances listed in the operating instructions and serving safety are in working order and that the product is ready for operation.

See the technical descriptions of the device.

Wear parts must be replaced with original components.

5.4.4 Warranty



NOTE

You will find the current warranty conditions in your order documents or in the price list valid at the time of purchase.

Repairs and spare parts in the event of improper use are also excluded.
Warranty work may only be carried out by trained specialists.

5.4.5 Product Service Life

The PROGNOST SH is designed for a service life of 10 years when used in accordance with the specifications and regular maintenance by PROTEC service department or a service company authorized by them. After the product has reached the end of its service life, further use is at your own risk.

5.4.6 Further Information

Detailed information to the individual chapters and for a safe operation, transport or storage can be found in the Technical Description of the PROGNOST SH.

5.4.7 Applied Parts and Parts Considered as Applied Parts

The patient does not come in contact with the PROGNOST SH during use. It is not necessary to define applied parts.

5.4.8 Disposal Notes



The PROGNOST SH contains different plastics and metals. When disposing exchange and spare parts, or if necessary, the entire device, the valid rules and regulations must be observed. Please contact your contractual partner or service company or commission a company specialized in disposing the respective components.

6 Power Supply



NOTE

The PROGNOST SH requires the following power supply:

Power supply:	230 VAC
Power frequency:	50/60 Hz
Input current:	2,5 – 6 A

The power supply for the electromagnetic brakes of the X-ray tube support stand and the X-ray operating unit is provided by a power supply with a power of 500W. This is mounted on the X-ray tube support stand. The power supply is connected directly to the generator with 230VAC; 6A 2,5A; and supplies 24VDC, 20.83A.



WARNING!

To avoid the risk of an electric shock, this device may only be connected to a supply network with a protective earth conductor.

6.1 Electromagnetic Compatibility (EMC) according to EN 60601-1-2



CAUTION!

As a medical electrical device, the PROGNOST SH is subject to special precautionary measures regarding EMC and must be installed and commissioned in accordance with the EMC information contained in the accompanying documents.



CAUTION!

Portable RF communication devices (radio devices) should not be used closer than 30 cm (12 in) to the marked parts and cables of the PROGNOST SH. Failure to observe can lead to a reduction in the performance characteristics of the device.

6.1.1 Guidelines and Manufacturer's Declaration – Electromagnetic interference

The PROGNOST SH is intended for use in the electromagnetic environment specified below. The customer or the Operator of the radiographic system should assure that it is used in such an environment.

Measurement interference	Compliance	Electromagnetic Environment
RF emissions CISPR 11	Group 1	The X-ray component uses RF energy exclusively for its internal function. As a result, its RF emissions are very low and it is unlikely that nearby electronic devices will be influenced.
RF emissions CISPR 11	Class A	The device is suitable for use in facilities other than residential areas and those that are directly connected to the public supply network, which also supplies buildings that are used for residential purposes, provided the following warning is observed:
Harmonic emissions EN 61000-3-2	Class A	
Voltage fluctuations/	compliant	

flicker emissions EN 61000-3-3		Warning: This device is intended for use by medical professionals only. This is a class A device according to CISPR 11. This device can cause radio interference in residential areas, in which case it must be necessary to take appropriate remedial measures such as new alignment, rearrangement or shielding of the device or filtering of the connection to the location.
-----------------------------------	--	--

Immunity Test	EN 60601-1-2 Test Level	Compliance Level	Electromagnetic Environment - Guidance
Electrostatic discharge (ESD) EN 61000-4-2	± 8 kV contact discharge ± 2 kV, ± 4 kV, ± 8 kV, ± 15 kV air discharge	± 8 kV contact discharge ± 2 kV, ± 4 kV, ± 8 kV, ± 15 kV air discharge	Floors should be made of wood, concrete or ceramic tiles. If the floor is covered with synthetic material, the relative humidity must be at least 30%.
Fast transient electrical disturbance variables / burst EN 61000-4-4	± 2 kV for power supply lines ± 1 kV for input/output lines	± 2 kV for power supply lines ± 1 kV for input/output lines	The quality of the supply voltage should correspond to that of a typical business or hospital environment.
Surges EN 61000-4-5	± 0,5 kV ± 1 kV ± 2 kV	± 0,5 kV ± 1 kV ± 2 kV	The quality of the supply voltage should be that of a typical commercial or hospital environment.
Magnetic field at the supply frequency (50/60 Hz) EN 61000-4-8	30 A/m 50/60 Hz	30 A/m 50/60 Hz	Magnetic fields at the mains frequency should correspond to the typical values found in a business and hospital environment.
Voltage dips, short interruptions and fluctuations in the supply voltage EN 61000-4-11	<5 % UT (>95 % dip in UT) for ½ cycle <5 % UT (>95 % dip in UT) for 1 cycle 70 % UT (30 % dip in UT) for 25/30 cycles <5 % UT (>95 % dip in UT) for 5/6s	<5 % UT (>95 % dip in UT) for ½ cycle <5 % UT (>95 % dip in UT) for 1 cycle 70 % UT (30 % dip in UT) for 25/30 cycles <5 % UT (>95 % dip in UT) for 5/6s	The quality of the supply voltage should correspond to that of a typical business or hospital environment. If the user of the device demands continued operation even if there are interruptions in the energy supply, it is recommended that the device be fed from an uninterruptible power supply or battery.
Conducted disturbances induced by RF fields EN 61000-4-6	3 V/m 1 kHz 80% AM 150 kHz bis 80 MHz	3 V/m	
Radiated RF disturbances EN 61000-4-3	3 V/m 1kHz 80% AM 80 MHz to 2.7 GHz	3 V/m	See table below
NOTE: These guidelines may not apply in all situations. Electromagnetic propagation is affected by absorption and reflection from structure, objects and people.			

Test Frequency in MHz	Frequency Band in MHz	Service in MHz	Modulation	Immunity Testing Level in V/m
385	380 - 390	TETRA 400	Pulse modulation: 18 Hz	27
450	430 – 470	GMRS 460, FRS 480	FM ±5 kHz Deviation 1 kHz Sine	28
710 745 780	704 – 787	LTE Band 13, 17	Pulse modulation: 217 Hz	9
810 870 930	800 – 960	GSM 800/900, TETRA 800, iDEN 820, CDMA 850, LTE Band 5	Pulse modulation: 18 Hz	28
1720 1845 1970	1700 - 1990	GSM 1800, CDMA 1900, GSM 1900, DECT, LTE Band 1, 3, 4, 25, UMTS	Pulse modulation: 217 Hz	28
2450	2400 – 2570	Bluetooth, WLAN, 802.11 b/g/n, RFID 2450, LTE Band 7	Pulse modulation: 217 Hz	28
5240 5500 5785	5100 - 5800	WLAN, 802.11 a/n	Pulse modulation: 217 Hz	9

7 Technical Data

7.1 Dimensions

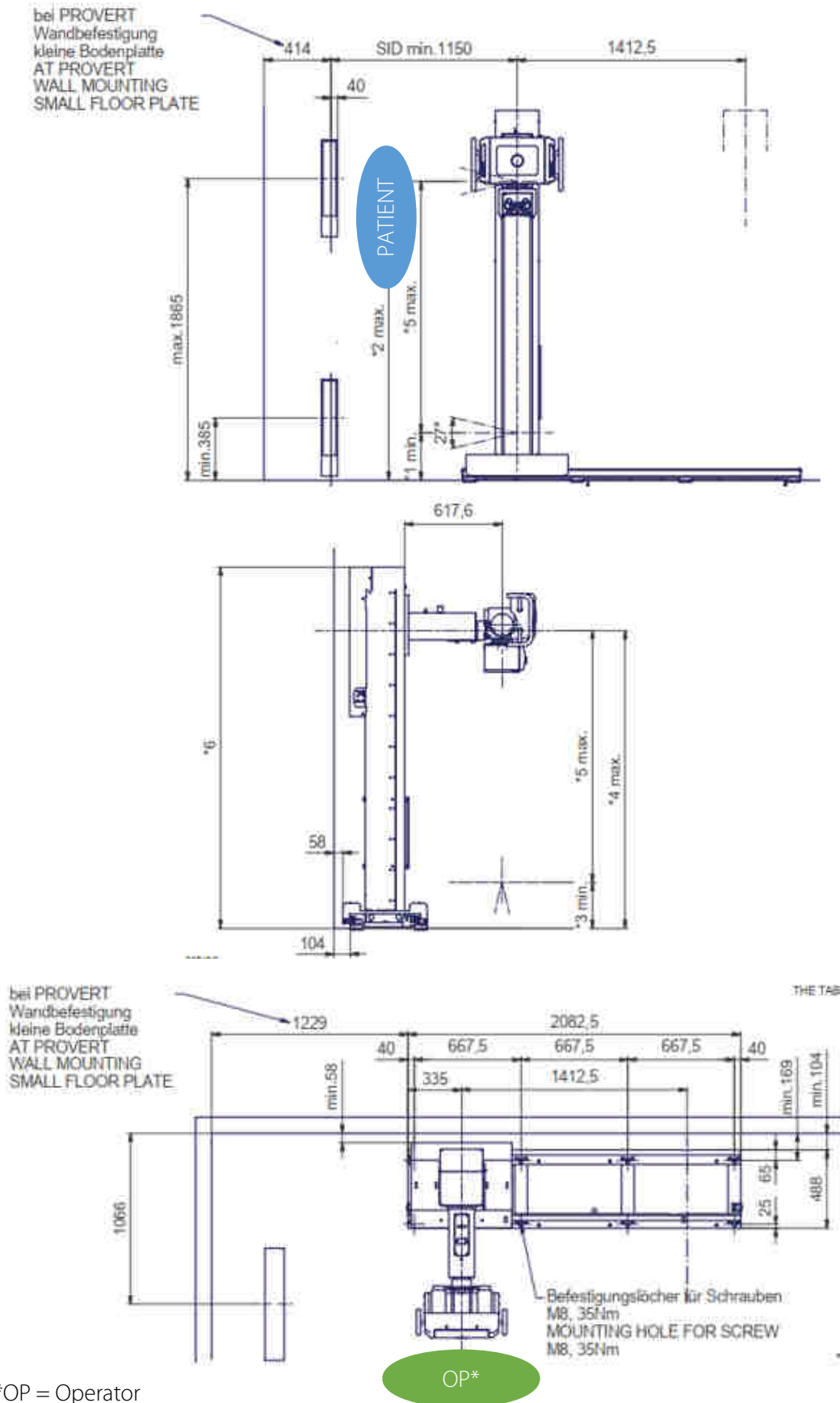

*OP = Operator

7.1.1 Traveling Distances

No.	Description	Versions PROGNOST SH (dimensions in mm)			
		Standard	Standard with telescopic arm	Rotation X-ray column	Rotation X-ray column with telescopic arm
1*	Min. distance floor (horizontal beam path, to image receiver stand)	297	302	309	315
2*	Max. distance floor (horizontal beam path, to image receiver stand)	1878	1883	1890	1896
3*	Min. distance floor (beam path to floor)	304	310	317	322
4*	Max. distance floor (beam path to floor)	1885	1891	1898	1903
5*	Vertical travel tube arm	1581			
6*	Max. height column	2297,5		2353	
	X-ray tube support, floor stand longitudinal displacement	1412,5			
	X-ray tube support, floor stand longitudinal displacement, with short rail extension	2078,5			
	X-ray tube support, floor stand longitudinal displacement, with long rail extension	3495			
	Telescopic arm extension (optional)	-	+230	-	+230
	Locking X-ray tube unit around the tube arm axis	- 90°, 0°, + 90°, 180°			
	Rotation X-ray tube unit around the tube arm axis	+/- 180°			
	Locking X-ray tube unit around the horizontal tube column	-		- 90°, 0°, + 90°, 180°	
	Rotation X-ray tube unit around the horizontal tube column	-		+/- 180°	

7.1.2 Total Weight

The maximum total weight of the PROGNOST SH with floor rails is:

For basic wagon and tube arm (X-ray tube and collimator 29kg):	343 kg
For basic wagon and telescopic arm (X-ray tube and collimator 27.5kg):	368 kg
For wagon with rotation and tube arm (X-ray tube and collimator 29kg):	372 kg
For wagon with rotation and telescopic arm (X-ray tube and collimator 27.5 kg):	398 kg

**NOTE**

The weight of the X-ray tube with collimator must not exceed 27.6 kg for the telescopic arm.

7.1.3 Protection Type and Protection Class

The PROGNOST SH corresponds to protection class 1 and does not contain applied parts.

7.2 Environmental Conditions**7.2.1 Environmental Conditions during Operation**













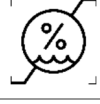

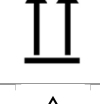
Ambient Temperature	+ 10°C to + 40°C
Relative humidity	30% to 75% (non-condensing)
Atmospheric pressure	700 hPa to 1060hPa

7.2.2 Environmental Conditions for Shipping and Storage



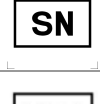
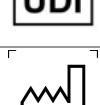







Ambient Temperature	- 10°C to + 70°C
Relative humidity	10% to 95% (non-condensing)
Atmospheric pressure	500 hPa to 1060hPa

8 Description of Symbols, Labels and Abbreviations

8.1 Symbols

	Atmospheric pressure limit
	Temperature limit
	Humidity limit
	Keep dry
	Fragile, Handle with care
	This way up
	Attention, observe accompanying documents
	Refer to Instructions for use
	CE marking
	Manufacturer
	Medical Device
	Order reference
	Serial number
	Unique Device Identification
	Production date
	Caution: pinch-/crushing hazard for hands and fingers
	This symbol indicates the need to observe the instructions for use. This is provided in an electronic format (eIFU) on our website.

www.protec-med.com/download

	Note on disposal; WEEE, Waste of Electrical and Electronic Equipment
	Protective ground (Earth)
	Caution: possibility of feet crushing
	Climbing forbidden
	Attention: Electrostatic sensitive devices
	Horizontal movement of the X-ray tube stand
	Vertical movement of the X-ray tube arm
	Rotation of the X-ray tube assembly
	Horizontal movement of the X-ray tube stand and vertical movement of the X-ray tube arm
	Transversal movement of the X-ray tube arm (optional)
	Electrical release for rotating the X-ray tube stand by ± 180° (optional)

8.2 Type Label

PROGNOST SH
X-ray system tube support, floor stand

POWER RATING

230	V	~
50	Hz	
2.5	A	

CE

UDI

(01)04260502641927
(11)250709
(21)SNxxxxxx



TL.7040-5-8000V04



PROTEC X-ray Systems GmbH
In den Dorfwiesen 14
71720 Oberstenfeld
Germany

www.protec-med.com/download

+40 °C 1060 hPa 75%
+10 °C 700 hPa 30%

8.3 Labels

Labels on the X-ray system tube support	
	Caution: pinch-/crushing hazard for hands and fingers
	Refer to Instructions for use

	<p>Caution: possibility of feet crushing</p>
	<p>Climbing forbidden</p>

8.4 Positions of the Signs and Labels

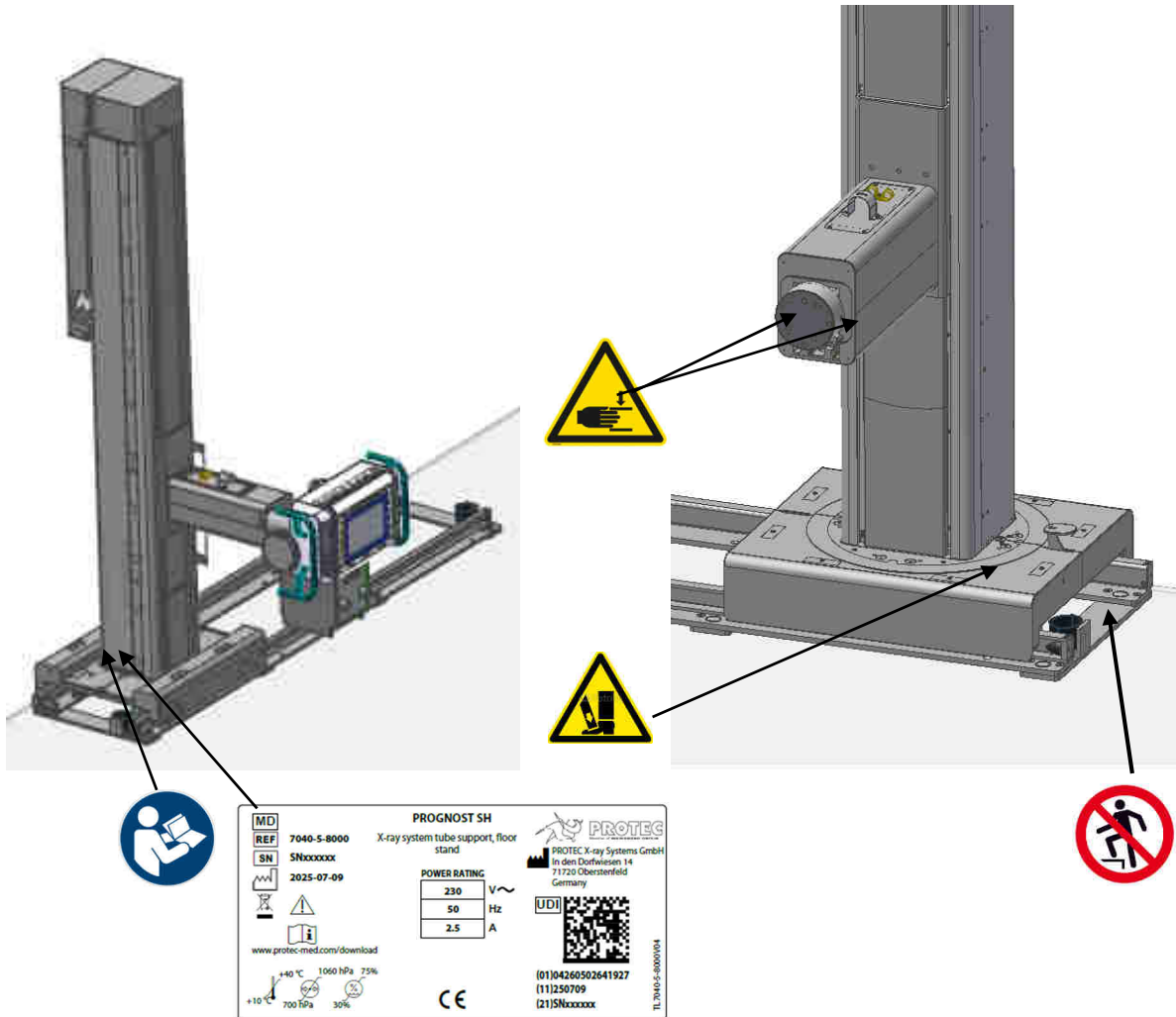

8.5 Abbreviations

mm	Millimetre
cm	Centimetre
kg	Kilogram
°C	Degree -Celsius
hPa	Hectopascal
DIN	German Industry Standard
EN	European Standard
CE	CE-Mark
Hz	Hertz
ED	Duty cycle
A	Ampere
SN	Serial number
VDC	Volt (DC Voltage)
VAC	Volt (AC Voltage)
W	Watt