

Stitching Autotracking

X-ray accessories for PRS 500 B

Model/ID: 4330-0-0022

Model/ID: 7010-0-0000

Additional Instructions for Use and Function for the PRS 500 B with option Stitching Autotracking

Ident. Nr.: 5010-0-5012

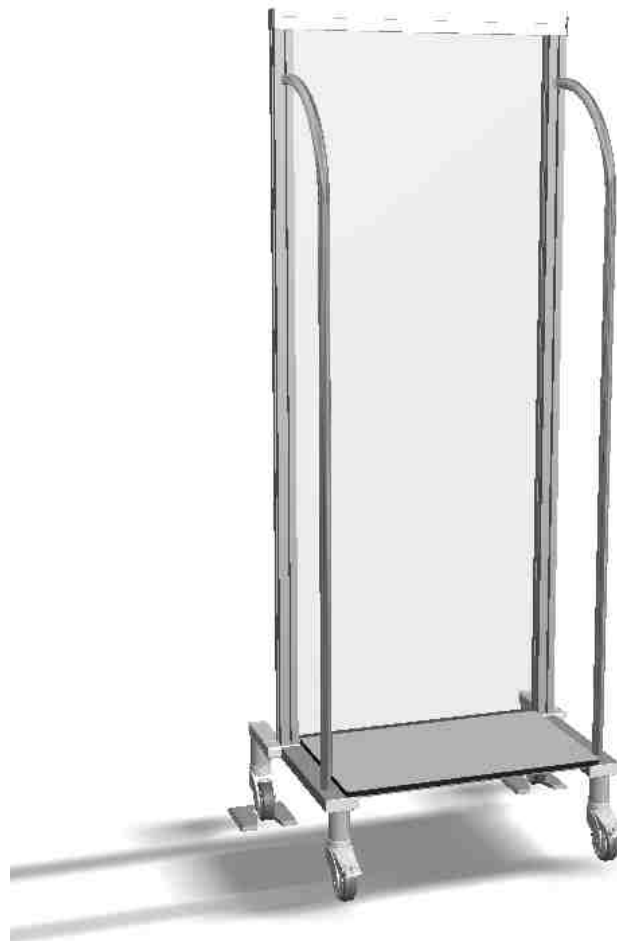



NOTE

All sheets of this document contain proprietary and confidential information of PROTEC X-ray Systems GmbH and is intended for exclusive use by current PROTEC X-ray Systems GmbH customers. Copying, disclosure to others or other use is prohibited without the express written consent of PROTEC's law department. Knowledge of violations of these regulations must be reported immediately to PROTEC X-ray Systems GmbH.

© 2025 PROTEC X-ray Systems GmbH, Oberstenfeld

Comments and questions about the documentation, please contact:

PROTEC X-ray Systems GmbH

In den Dorfwiesen 14 | 71720 Oberstenfeld
Germany

Phone: (+ 49) 7062 – 92 55 0

Fax: (+ 49) 7062 – 92 55 60

E-Mail: protec@protec-med.com

Internet: www.protec-med.com

Table of contents

	Page
Table of contents	3
Revision Status	5
To the User	6
1 Device Description	7
1.1 Introduction	7
1.2 Description.....	7
1.2.1 Components	7
1.2.2 Installation	7
1.3 Performance Characteristics	8
1.4 Intended User Group.....	8
2 Safety Instructions	9
2.1 General Safety Instructions.....	10
2.1.1 Operation	10
2.1.2 Operating Personnel	10
2.1.3 Crushing and Collision Hazard.....	10
2.1.4 Explosion Protection	10
2.1.5 Interaction with Other Devices.....	10
3 Control Elements and Displays	11
3.1 Main Switch.....	11
3.2 Emergency Stop Switches.....	11
3.2.1 Generator Emergency Stop Switch.....	11
3.3 Control Elements and Displays of Stitching Autotracking	11
3.3.1 STITCHING TROLLEY	Fehler! Textmarke nicht definiert.
3.3.2 Stitching Assistant.....	11
4 Handling	12
4.1 Requirements before and during Operation.....	12
4.2 Operation of the STITCHING TROLLEY.....	12
4.2.1 Adjustment of the exposure position	12
4.3 Operation of Stitching Autotracking	13
4.3.1 Workflow Stitching Autotracking Full Leg.....	14
4.3.2 Workflow Stitching Autotracking Full Spine.....	17
4.4 Function of Stitching Autotracking.....	19
4.4.1 Switching Stitching Autotracking on and off	19
5 Safety and Maintenance	20
5.1 Introduction	20
5.2 Reusability	20
5.3 Cleaning and Disinfection	20
5.3.1 Cleaning.....	Fehler! Textmarke nicht definiert.
5.3.2 Disinfection	Fehler! Textmarke nicht definiert.
5.4 Inspection and maintenance	Fehler! Textmarke nicht definiert.
5.4.1 Daily Monitoring before and during the Examination Operation..	Fehler! Textmarke nicht definiert.
5.4.2 Warranty.....	Fehler! Textmarke nicht definiert.
5.4.3 Product Service Life	Fehler! Textmarke nicht definiert.
5.4.4 Disposal Notes	Fehler! Textmarke nicht definiert.
6 Power Supply	Fehler! Textmarke nicht definiert.
7 Technical Data	21
7.1 Dimensions Stitching Trolley.....	21
7.2 Attenuation Equivalent.....	Fehler! Textmarke nicht definiert.
7.3 Environmental Conditions	Fehler! Textmarke nicht definiert.
7.3.1 Environmental Conditions during Operation.....	Fehler! Textmarke nicht definiert.

7.3.2	Environmental Conditions for Shipping and Storage ...	Fehler! Textmarke nicht definiert.
8	Description of Symbols, Labels and Abbreviations	22
8.1	Symbols	Fehler! Textmarke nicht definiert.
8.2	Type Label	Fehler! Textmarke nicht definiert.
8.3	Labels	Fehler! Textmarke nicht definiert.
8.4	Positions of the Signs and Labels.....	Fehler! Textmarke nicht definiert.
8.5	Abbreviations	Fehler! Textmarke nicht definiert.

**NOTE**

The information contained in this document conforms to the configuration of the equipment as of the date of manufacture. Revisions to the equipment subsequent to the date of manufacture will be addressed in service updates distributed to the PROTEC Technical Service Organisation.

Revision Status

Revision	Date	Updated pages	Comments	Author
1.0	2022-09-20	all	new	MB/DP
2.0	2023-02-14	all	IfU, for only, STITCHING TROLLEY in separate manual 5010-0-5002 Doc ID changed	ML
3.0	2025-07-01	All	First edition PROTEC X-ray Systems GmbH	ML

To the User

**NOTE**

The user of these accompanying documents is required to carefully read through and carefully consider the instructions, warnings and cautions contained therein before starting operation.

Even if you have already operated similar systems, changes in the design, production and functional routine of the system described here may have been made, which have a significant influence on the operation.

Assembly and service works on the system described here must be carried out by authorised and qualified personnel from PROTEC X-ray Systems GmbH. Assembly personnel and other persons who are not employees of the technical service department of PROTEC X-ray Systems GmbH are requested to contact the local branch of PROTEC X-ray Systems GmbH before assembly or service work is started. For assembly and service works, it is necessary to use the "Technical Description" of the product and to observe the points it contains.

**NOTE**

The use of the product with add-on or accessory parts not authorized by PROTEC or other unapproved components is not permitted.

1 Device Description

1.1 Introduction

This instructions for use describe the performance characteristics and operation required for efficient and effective use of Stitching Autotracking including the STITCHING TROLLEY.

Before you work with Stitching Autotracking, the complete instructions for use must be read, especially the Safety Instructions and the chapter Handling.

1.2 Description

These instructions for use describe the Stitching Autotracking process of single X-ray exposures to a total image. This requires the use of the CONAXX 2 software with the "CONAXX 2 Stitching" module (4330-0-0022), the STITCHING TROLLEY (7010-0-5000) and a PROTEC RAPIXX detector.

The STITCHING TROLLEY is a patient carriage for digital stitching exposures at X-ray system PRS 500 B. It is positioned in front of the Bucky wall stand for the exposures.

1.2.1 Components

In addition to the X-ray system PRS 500 B, following components are required for Stitching Autotracking:

- CONAXX 2 with Stitching Autotracking module
- STITCHING TROLLEY with floor fixation
- RAPIXX Detector

Accessories that can influence the EMC conditions

- Network cable ((take note of the max. cable length in the system documents)
- RAPIXX data connection cable (take note of the max. cable length in the system documents)
- WiFi router (Only use devices approved by PROTEC)

1.2.2 Installation



NOTE

The installation of Stitching Autotracking must be performed by PROTEC service department or a service company authorized by them.

Contact information of persons qualified to perform installations are available upon request at:

PROTEC X-ray Systems GmbH

In den Dorfwiesen 14 | 71720 Oberstenfeld
Germany

Phone: (+ 49) 7062 – 92 55 0

Fax: (+ 49) 7062 – 92 55 60

E-Mail: protec@protec-med.com

Internet: www.protec-med.com

1.3 Performance Characteristics

- Large stitching range
- Images of full leg and full spine possible
- Integrated Stitching assistant for easy operation
- Easy manoeuvrability of the STITCHING TROLLEY
- Easy positioning of the patient on the STITCHING TROLLEY

1.4 Intended User Group

As an accessory of a diagnostic X-ray system PRS 500 B, the STITCHING TROLLEY is intended exclusively for use by professional users who are trained in the operation of diagnostic X-ray systems in accordance with the respective national regulations and who are familiar with the proper handling, use and operation and also have been instructed in the permitted conjunction with other medical products, objects and accessories.

Appropriate users can be, for example: X-ray technicians, X-ray assistants, medical technical X-ray assistants, surgeons, casualty surgeons, orthopaedists and other trained medical personnel.

2 Safety Instructions



NOTE

Contains information that must be observed during operation.

xxx



CAUTION!

Contains information which, if not observed, can cause property damage.

xxx



WARNING!

Contains information which, if not followed, can cause personal injury.

xxx



WARNING!

Warning of radioactive substances or ionizing radiation. Contains information which, if not observed, can cause personal injury.

xxx

Settings and calibrations that are not described in these instructions for use must be carried out using the supplied documents by the PROTEC service department or a service company authorized by them.



NOTE

All instructions supplied with Stitching must be observed and the safety instructions contained therein must be carefully read and adhered to.



NOTE

Stitching may only be commissioned if all safety measures for operator protection have been met and checked. These protective measures can include door contact, designated area, dosimeter, protective clothing, etc.



CAUTION!

The instructions for use contain all the information relevant to safety in order to generally put Stitching into operation. The device may only be operated by appropriately trained and trained personnel. In this context, operation is ensured by clear symbols on the control elements. All further information and instructions can be found on the supplied data carrier (USB, CD or DVD). This information applies in its entirety as an appendix to these instructions for use and must be observed.



NOTE

All control elements are described again in detail in these operating instructions.



WARNING!

The STITCHING TROLLEY is not suitable for patient transport.

2.1 General Safety Instructions

2.1.1 Operation

In case of a malfunction, do not use Stitching Autotracking anymore and notify PROTEC service department or a service company authorized by them.

2.1.2 Operating Personnel



NOTE

Only trained and authorized personnel are allowed to work with Stitching Autotracking.



NOTE

The operating personnel must be familiar with all warning signs attached to the Stitching Autotracking components. They are used for your own safety and that of others and ensure proper operation.

2.1.3 Crushing and Collision Hazard



WARNING!

It must be ensured that when operating the moving parts, no persons or objects are in the obvious danger area of the device. If not observed, it can result in personal injury or damage to the STITCHING TROLLEY or other objects.



WARNING!

Danger if tipping! Don't step on the edge of the board! Do not shift your body weight backwards when stepping on! Do not pull your body weight up on the grab pole!

2.1.4 Explosion Protection

Stitching Autotracking is not designated for use within areas with explosive hazards.

2.1.5 Interaction with Other Devices

Interactions with other devices are not known.

3 Control Elements and Displays

3.1 Main Switch

Stitching Autotracking is performed with switched on X-ray system. The main switch of the respective PRS 500 B is described in the corresponding instructions for use.

3.2 Emergency Stop Switches

Stitching Autotracking is performed with switched on X-ray system. The emergency stop switches of the respective PRS 500 B are described in the corresponding instructions for use.

3.2.1 Generator Emergency Stop Switch

For the switch position of the corresponding X-ray generator, please refer to the enclosed instructions for use of the generator.

3.3 Control Elements STITCHING TROLLEY



NOTE

See instructions for use for a detailed description of the STITCHING TROLLEY.

3.4 Control Elements and Displays of Stitching Autotracking

3.4.1 Stitching Assistant

When using the PRS 500 B system, the stitching area is displayed in case of stitching exposures. The display reflects the contents of the CONAXX2 Stitching assistant.

Test, Patient (18/05/2012)
Pelvis > STITCHING pelvis with thigh > AP

- Move the table to the lowest position (59cm)
- Move the wall stand Bucky to the middle exposure position (90cm)
- Rotate the tube to the wall stand (90°)
- Set the source-image distance (300cm)
- Move the tube until it stops automatically (90cm)
- If necessary, adjust the laser to the Bucky center
- Move the tabletop away from the wall stand
- Position the patient on the trolley and adjust the collimation to the upper edge of the pelvic bone

300 cm
90 °
59 cm

Cancel X Next >>



NOTE

The workflow corresponds to the procedure described in chapter "4.3 Operation of Stitching Autotracking".



NOTE

See CONAXX2 instructions for use for a detailed description of CONAXX2.

4 Handling

4.1 Requirements before and during Operation

It must be ensured that the surfaces in contact with patients are disinfected before the X-ray examination of each patient (see chapter 5.3).

4.2 Operation of the STITCHING TROLLEY

4.2.1 Adjustment of the exposure position

Move the STITCHING TROLLEY into the exposure position in front of the wall stand. The rollers on the backside must be placed into the floor fixation (1) and the holding brake (2) must be locked.

Before the patient is ascending (positioned), check again that the STITCHING TROLLEY is securely in place, the rollers are in the floor fixation and the holding brakes are activated.



WARNING!

Danger if tipping! Don't step on the edge of the board! Do not shift your body weight backwards when stepping on! Do not pull your body weight up on the grab pole!



**WARNING!**

It is imperative to ensure that the brake rollers with the brake lever are pointing forwards, as shown in the illustration, and are not rotated under the STITCHING TROLLEY.

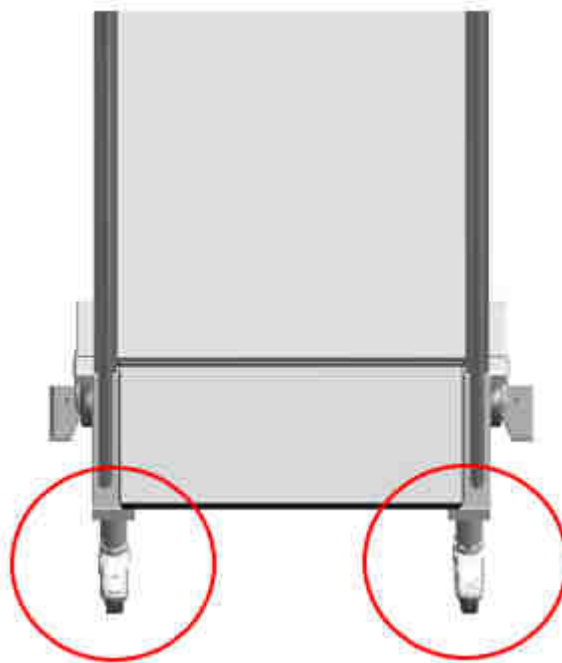

Fig. brake rollers

4.3 Operation of Stitching Autotracking

**NOTE**

- The patient must not move during the exposures.
- The distance between the detector and the radiation source should be 300 cm for Stitching Autotracking exposures.

**NOTE**

See CONAXX2 instructions for use for a detailed description of CONAXX2.

**WARNING!**

The exposures with Stitching Autotracking can and may only be triggered if all points in the stitching assistant in CONAXX2 are checked off in green.

4.3.1 Workflow Stitching Autotracking Full Leg



WARNING!

Stitching Autotracking for full leg exposures must be performed with the base plate inserted.

1. Select the quick job "Full leg AP" and click "Create job". As a result, three x-ray jobs will be created in the x-ray job list.
2. Select the first x-ray job "Pelvis > STITCHING pelvis with thigh > AP" and click "Start exposure". A warning dialog appears.
3. Please ensure that no person is on the table or in close vicinity to the system. Confirm the warning dialog with "OK".
4. Observe the warning regarding the handling of the Stitching Trolley. Confirm the warning dialog with "OK".

5. An assistant will appear, which guides you through the necessary settings.

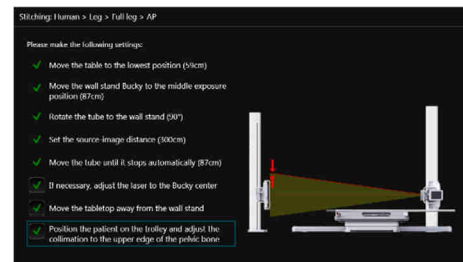

- a. Move the table to the lowest position
(this step is done automatically by the system)



- b. Move the wall stand Bucky to the middle exposure position
(this step is done automatically by the system)



- c. Rotate the tube to the wall stand (90°)



d. Set the source-image distance (300 cm)



e. Move the tube down until it stops automatically



f. If necessary, adjust the laser to the Bucky centre



g. Move the tabletop away from the wall stand



h. Position the patient on the trolley and adjust the collimation to the upper edge of the pelvic bone

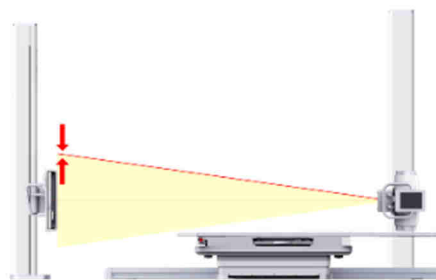

6. After all the settings have been made, confirm the steps f), g) and h) by ticking the respective check box. If all steps are ticked off with a green tick, you can continue by clicking on "OK".

7. The system will show the complete collimation of all exposures. Confirm it by clicking on "OK".

8. The exposure dialog appears. The Bucky of the wall stand automatically moves to the first exposure position (top) and the collimation will be adjusted for the first exposure. Wait until the Bucky has reached its position and the collimation is set. Check the generator settings. As soon as the generator and the detector are ready, the status changed from "Preparing exposure..." to "Please perform the exposure".

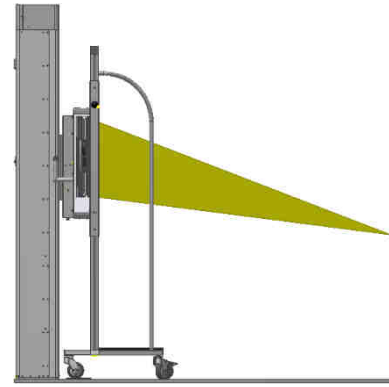

9. Perform the exposure with the hand switch of the generator. After the image has been transferred from the detector, the Bucky of the wall stand automatically moves to the second exposure position (middle) and the collimation will be adjusted for the second exposure. After the image optimization is completed, the image must be checked. Therefore, you can use the full screen mode (🖥️). If the exposure must be repeated click on "Repeat", otherwise on "Next".

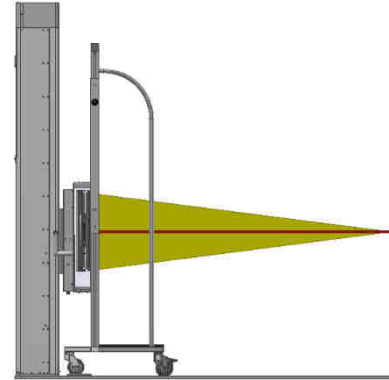

10. The exposure dialog for the second exposure appears. Wait until the Bucky has reached its position and the collimation is set. Check the generator settings. As soon as the generator and the detector are ready, the status changed from "Preparing exposure..." to "Please perform the exposure".

11. Perform the second exposure with the hand switch of the generator. After the image has been transferred from the detector, the Bucky of the wall stand automatically moves to the third exposure position (bottom) and the collimation will be adjusted for the third exposure. After the image optimization is completed, the image must be checked. If the exposure must be repeated click on "Repeat", otherwise on "Next".

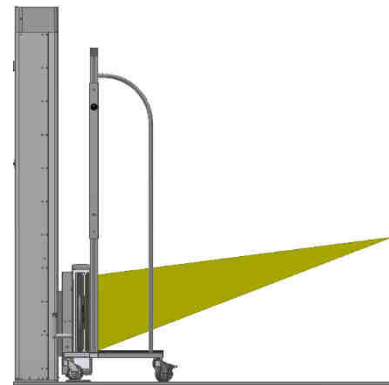

12. The exposure dialog for the third exposure appears. Wait until the Bucky has reached its position and the collimation is set. Check the generator settings. As soon as the generator and the detector are ready, the status changed from "Preparing exposure..." to "Please perform the exposure".

13. Perform the third exposure with the hand switch of the generator. After the image has been transferred from the detector and the image optimization is finished, the image must be checked. If the exposure must be repeated click on "Repeat", otherwise on "Next".

14. You will automatically be redirected to the X-ray area. There the single exposures will be automatically stitched to one exposure.

4.3.2 Workflow Stitching Autotracking Full Spine



WARNING!

Stitching Autotracking for full spine exposures must be performed with the base plate removed.

1. Select the quick job "Full spine AP", "Full spine LL" or "Full spine RL" and click "Create job". As a result, two x-ray jobs will be created in the x-ray job list.
2. Select the first x-ray job ("Chest > STITCHING T-spine with C-spine > AP", "Chest > STITCHING T-spine with C-spine > LL" or "Chest > STITCHING T-spine with C-spine > RL") and click "Start exposure". A warning dialog appears.
3. Please ensure that no person is on the table or in close vicinity to the system. Confirm the warning dialog with "OK".
4. Observe the warning regarding the handling of the Stitching Trolley. Confirm the warning dialog with "OK".

5. An assistant will appear, which guides you through the necessary settings.

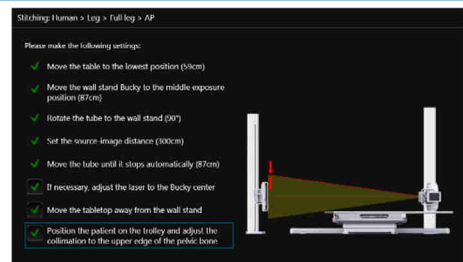





- a. Move the table to the lowest position
(this step is done automatically by the system)



- b. Rotate the tube to the wall stand (90°)

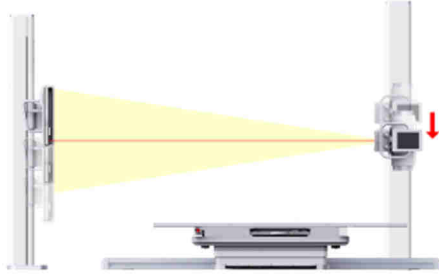

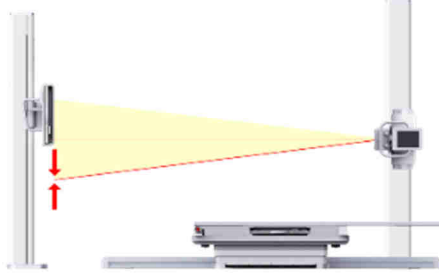
<p>c. Set the source-image distance (300 cm)</p>	
<p>d. If necessary, adjust the laser to lower border of the active area format</p>	
<p>e. Position the patient in the trolley and adjust the wall stand Bucky to the upper edge of the ears</p>	
<p>f. Move the tube stand to the height of the lower border of the active area format <i>(this step is done automatically by the system)</i></p>	
<p>g. Move the table top away from the wall stand</p>	
<p>h. Adjust the lower collimation to the height of the coccyx</p>	

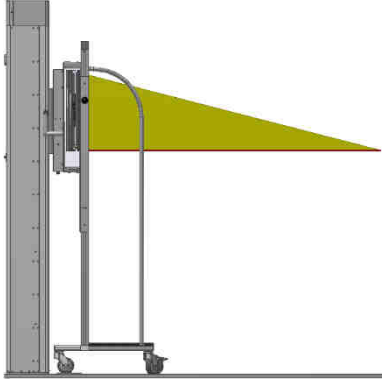
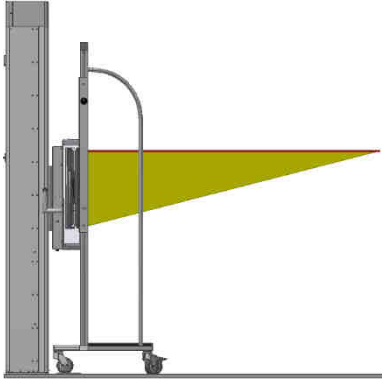
<p>6. After all the settings have been made, confirm the steps d), f), g) and h) by ticking the respective check box. If all steps are ticked off with a green tick, you can continue by clicking on "OK".</p>	
<p>7. The system will show the complete collimation of all exposures. Confirm it by clicking on "OK".</p>	
<p>8. The exposure dialog appears. The collimation will be adjusted for the first exposure (top). Check the generator settings. As soon as the generator and the detector are ready, the status changed from "Preparing exposure..." to "Please perform the exposure".</p>	
<p>9. Perform the exposure with the hand switch of the generator. After the image has been transferred from the detector, the Bucky of the wall stand automatically moves to the second exposure position (middle) and the collimation will be adjusted for the second exposure. After the image optimization is completed, the image must be checked. Therefore, you can use the full screen mode (🖥️). If the exposure must be repeated click on "Repeat", otherwise on "Next".</p>	
<p>10. The exposure dialog for the second exposure appears. Wait until the Bucky has reached its position and the collimation is set. Check the generator settings. As soon as the generator and the detector are ready, the status changed from "Preparing exposure..." to "Please perform the exposure".</p>	
<p>11. Perform the second exposure with the hand switch of the generator. After the image has been transferred from the detector and the image optimization is finished, the image must be checked. If the exposure must be repeated click on "Repeat", otherwise on "Next".</p>	
<p>12. You will be automatically redirected to the X-ray area. There, the single exposures will be automatically stitched to one exposure.</p>	

4.4 Function of Stitching Autotracking

4.4.1 Switching Stitching Autotracking on and off

The X-ray system with integrated Stitching functionality is switched on via the generator console. All system components are supplied with voltage via the generator. If the system contains a Power Box, the power is supplied via the Power Box.

When the generator or Power Box is powered up using the switch-on button, a self-test runs on the generator and the control desk. After successful completion of the self-test, the parameters are displayed.

Stitching exposures can be started and performed via the CONAXX2 operating software.

5 Safety and Maintenance

5.1 Introduction

In this chapter you will find information about safety and maintenance that are necessary to ensure the correct and reliable function of the device after installation.

5.2 Reusability

Stitching Autotracking can be reused without any special preparation procedures.

However, it must be ensured that the surfaces in contact with patients are disinfected before the X-ray examination of each patient (see also chapter 4.1).

The STITCHING TROLLEY must no longer be used with patients if it shows signs of wear (e.g., metal abrasion, wear of insulations) or dangerous technical defects (e.g., bent parts) or if the resulting image quality (e.g., artifacts in the image) is insufficient.

In this case, please contact PROTEC service department or a service company authorized by them immediately.

5.3 Cleaning and Disinfection



NOTE

See instructions for use STITCHING TROLLEY for a detailed description of the STITCHING TROLLEY.

6 Technical Data

6.1 Dimensions Stitching Trolley



NOTE

See instructions for use STITCHING TROLLEY for a detailed description of the STITCHING TROLLEY.

7 Description of Symbols, Labels and Abbreviations

7.1 STITCHING TROLLEY



NOTE

See instructions for use STITCHING TROLLEY for a detailed description of the STITCHING TROLLEY.
