

INTERFACE BOX

DR-System Interface Component

Model/ID: 4499-9-xxxx
Basis UDI: 426050264D004V5

Installation Manual & Instructions for use

ID no. 5099-0-3002



**NOTE**

All sheets of this document contain proprietary and confidential information of PROTEC X-ray Systems GmbH and is intended for exclusive use by current PROTEC X-ray Systems GmbH customers. Copying, disclosure to others or other use is prohibited without the express written consent of PROTEC's law department. Knowledge of violations of these regulations must be reported immediately to PROTEC X-ray Systems GmbH.

© 2025 PROTEC X-ray Systems GmbH, Oberstenfeld

Comments and questions about the documentation, please contact:

PROTEC X-ray Systems GmbH

In den Dorfwiesen 14 | 71720 Oberstenfeld
Germany

Phone: (+ 49) 7062 – 92 55 0

Fax: (+ 49) 7062 – 92 55 60

E-Mail: protec@protec-med.com

Internet: www.protec-med.com

Table of contents

	Page
Table of contents	3
Revision Status	5
General Notes	6
Mechanical and Electric Warning	6
To the User	6
1 Device Description	7
1.1 Introduction	7
1.2 Description.....	7
1.2.1 Versions	7
1.2.2 Obligatory Combination Products	7
1.2.3 Hardware and Network System Requirements	7
1.2.4 Installation	7
1.3 Intended Use	8
1.4 Clinical Benefit	8
1.5 Patient Target Group(s)	8
1.6 Medical Conditions to be diagnosed	8
1.7 Indications and Contraindications	8
1.8 Intended User Group.....	8
1.9 Declaration of Conformity.....	8
2 Safety Instructions	9
2.1 General Safety Instructions	10
2.1.1 Device Operation	10
2.1.2 Operating Personnel	10
2.1.3 Explosion Protection	10
2.1.4 Interaction with Other Devices.....	10
2.1.5 Electromagnetic Environment and Influencing of Devices	10
3 Installation and Calibration	11
3.1 Checking the Package	11
3.2 Checking the Scope of Delivery.....	11
3.3 Installation	12
3.4 Calibration	14
4 Control Elements and Displays	15
4.1 Signal-LEDs of the INTERFACE BOX	15
5 Handling	16
5.1 Operation of the INTERFACE BOX.....	16
6 Safety and Maintenance	17
6.1 Introduction	17
6.2 Reusability	17
6.3 Cleaning and Disinfection.....	17
6.3.1 Cleaning.....	17
6.3.2 Disinfection	17
6.4 Inspection and Maintenance.....	18
6.4.1 Daily Monitoring before and during the Examination Operation.....	18
6.4.2 Safety-related Checks	18
6.4.3 Maintenance	18
6.4.4 Warranty.....	18
6.4.5 Product Service Life	18
6.4.6 Disposal Notes	18
7 Power Supply	19
7.1 Electromagnetic Compatibility (EMC) according to EN 60601-1-2	19
7.1.1 Guidelines and Manufacturer's Declaration – Electromagnetic interference.....	19
8 Technical Data	22

8.1	Dimensions.....	22
8.2	Total Weight.....	22
8.2.1	Protection Type and Protection Class	22
8.2.2	Health Hazards.....	22
8.3	Environmental Conditions	22
8.3.1	Environmental Conditions during Operation.....	22
8.3.2	Environmental Conditions for Shipping and Storage	22
9	Description of Symbols, Labels and Abbreviations	23
9.1	Symbols	23
9.2	Type Labels.....	24
9.3	Positions of the Signs and Labels.....	25
9.4	Abbreviations.....	25

**NOTE**

The information contained in this document conforms to the configuration of the equipment as of the date of manufacture. Revisions to the equipment subsequent to the date of manufacture will be addressed in service updates distributed to the PROTEC Technical Service Organisation.

Revision Status

Revision	Date	Updated pages	Comments	Author
5.0	2022-01-25	all	Original issue in MDR Layout	MB
6.0	2025-07-18	All	First Edition PROTEC X-ray Systems GmbH	ML

General Notes

**WARNING!**

In order to maintain the set and tested requirements of the 60601 series of standards, the ME system must not be modified during its actual operating life.

Mechanical and Electric Warning

**WARNING!**

All of the movable assemblies and parts of this equipment should be operated with care and routinely inspected in accordance with the manufacturer's recommendations contained in the equipment accompanying documents. Maintenance and service is only to be performed by customers authorized by PROTEC X-ray Systems GmbH.

Live electrical terminals are deadly.

Do not remove flexible high-tension cables from X-ray tube cover or high-tension generator and/or access covers from X-ray generator.

For all components of the equipment protective earthing means must be provided in compliance with the national regulations.

Failure to comply with the foregoing may result in serious or fatal bodily injuries to the operator or those in the area.

To the User

**NOTE**

The user of these accompanying documents is required to carefully read through and carefully consider the instructions, warnings and cautions contained therein before starting operation.

Even if you have already operated similar systems, changes in the design, production and functional routine of the system described here may have been made, which have a significant influence on the operation.

Assembly and service works on the system described here must be carried out by authorised and qualified personnel from PROTEC X-ray Systems GmbH. Assembly personnel and other persons who are not employees of the technical service department of PROTEC X-ray Systems GmbH are requested to contact the local branch of PROTEC X-ray Systems GmbH before assembly or service work is started. For assembly and service works, it is necessary to use the "Technical Description" of the product and to observe the points it contains.

**NOTE**

The use of the product with add-on or accessory parts not authorized by PROTEC or other unapproved components is not permitted.

**NOTE**

According to Regulation (EU) 2017/745 of medical devices, all serious incidents related to the device must be reported to the manufacturer and the responsible authority of the Member State where the user and/or the patient is established.

1 Device Description

1.1 Introduction

The instructions for use describe the performance characteristics and operation required for efficient and effective use of the INTERFACE BOX.

Before you work with the INTERFACE BOX, the complete instructions for use must be read, especially the Safety Instructions and the chapter Handling.

1.2 Description

The INTERFACE BOX is a signal converter for connection to the acquisition console of a DR system. It can query the states of various switches and sensors of the X-ray system and route them to the acquisition console. Furthermore, it transfers switching signals from the acquisition console to the X-ray generator. It is not responsible for signal control and monitoring. This is done by the CONAXX 2 software installed on the acquisition console.

The INTERFACE BOX consists of a black plastic housing in which the electronics and connection terminals are installed. There are signal LEDs on the front panel of the housing, from which it can be read whether the power supply of the INTERFACE BOX is working and the current switching state of the installed relays.

The connectors for the connection with the generator and the manual switch are designed as terminal connections inside the box. The cable can be led through the front panel to the outside.

The USB cable connected inside of the box is connected to the PC running the CONAXX 2 software. The corresponding driver is installed during the installation of CONAXX 2.

The INTERFACE BOX is delivered with an already connected plug-in power supply, which must be plugged into a wall socket.

1.2.1 Versions

INTERFACE BOX	4499-9-5001
INTERFACE BOX - Siemens	4499-9-8001

The *INTERFACE BOX* is designed for:

- digital X-ray systems with iRay detector and a generator of the PROVARIO, Venus or CPI-series.
- the grid detection function for digital X-ray system with any detector and a generator of the PROVARIO, Venus or CPI-series.

The *INTERFACE BOX – Siemens* is designed for:

- digital X-ray systems with any detector and generator of the Polydoros RFX-series.

1.2.2 Obligatory Combination Products

- Detector (iRay, Fujifilm)
- CONAXX 2 Software
- X-ray generator of the PROVARIO, VENUS, CPI or Polydoros RFX-series

1.2.3 Hardware and Network System Requirements

As a stand-alone product, the INTERFACE BOX has no hardware or network connection and therefore no hardware or network requirements.

For the smooth operation of the INTERFACE BOX, it is necessary to use a PROTEC approved RAPIXX system and a generator.

1.2.4 Installation

See chapter 3.

1.3 Intended Use

The INTERFACE BOX is intended as a component of a DR system for querying various switches and sensors as well as for signal conversion and transduction to the acquisition console and the X-ray generator.

The INTERFACE BOX is not responsible for signal control and monitoring. This is done by the software installed on the acquisition console.

1.4 Clinical Benefit

Considered in isolation, no clinical benefit can be shown for INTERFACE BOXES.

As components of diagnostic X-ray detector systems in human medicine, they contribute to the clinical benefit, in combination with a diagnostic X-ray system, which consists of the generation of conventional two-dimensional X-ray images for creation or specification of findings as a basis for treatment decisions.

1.5 Patient Target Group(s)

The intended patient group includes all people for whom a justifying indication for a medical X-ray has been given by a physician with the necessary expertise in radiation protection.

There are no general or fundamental restrictions on the patient group regarding age, gender, origin and patient condition.

1.6 Medical Conditions to be diagnosed

As standalone products, INTERFACE BOXES, have no function to diagnose, treat and/or monitor medical conditions.

1.7 Indications and Contraindications

As standalone products, INTERFACE BOXES have no intended main effect in or at the human body. Therefore, considered in isolation, no indications or contraindications can be shown for them.

1.8 Intended User Group

As a component of a diagnostic X-ray detector system, the INTERFACE BOX is intended exclusively for use by professional users who are trained in the operation of diagnostic X-ray systems, in combination with a digital X-ray detector system, in accordance with the respective national regulations and who are familiar with the proper handling, use and operation and also have been instructed in the permitted conjunction with other medical products, objects and accessories.

Appropriate users can be, for example: X-ray technicians, X-ray assistants, medical technical X-ray assistants, surgeons, casualty surgeons, orthopaedists and other trained medical personnel.

1.9 Declaration of Conformity



This product complies with the requirements of Regulation (EU) 2017/745 of the European Parliament and of the Council of 5 April 2017 on medical devices, including all applicable corrigenda.

The declaration of conformity is available upon request from PROTEC:

PROTEC X-ray Systems GmbH

In den Dorfwiesen 14 | 71720 Oberstenfeld

Germany

Phone: (+ 49) 7062 – 92 55 0

Fax: (+ 49) 7062 – 92 55 60

E-Mail: protec@protec-med.com

Internet: www.protec-med.com

2 Safety Instructions



NOTE

Contains information that must be observed during operation.

xxx



CAUTION!

Contains information which, if not observed, can cause property damage.

xxx



WARNING!

Contains information which, if not followed, can cause personal injury.

xxx



WARNING!

Warning of radioactive substances or ionizing radiation. Contains information which, if not observed, can cause personal injury.

xxx

Settings and calibrations that are not described in these instructions for use must be carried out using the technical description of the device by PROTEC service department or a service company authorized by them.



NOTE

All instructions supplied with the INTERFACE BOX must be observed and the safety instructions contained therein must be carefully read and adhered to.



NOTE

After the initial installation, the commissioning must be recorded with the PROTEC acceptance protocol FB-04-07A4.



NOTE

The INTERFACE BOX may only be commissioned if all safety measures for operator protection have been met and checked. These protective measures can include door contact, designated area, dosimeter, protective clothing, etc.



CAUTION!

The instructions for use contain all the information relevant to safety in order to generally put the INTERFACE BOX into operation. The device may only be operated by appropriately trained and trained personnel. In this context, operation is ensured by clear symbols on the control elements. All further information and instructions can be found on the supplied data carrier (USB, CD or DVD). This information applies in its entirety as an appendix to these instructions for use and must be observed.



NOTE

All control elements are described again in detail in these operating instructions.

2.1 General Safety Instructions

2.1.1 Device Operation

In case of a malfunction, do not use the INTERFACE BOX anymore and notify PROTEC service department or a service company authorized by them.

2.1.2 Operating Personnel



NOTE

Only trained and authorized personnel are allowed to work on the INTERFACE BOX.



NOTE

The operating personnel must be familiar with all warning signs attached to the INTERFACE BOX. They are used for your own safety and that of others and ensure proper operation.

2.1.3 Explosion Protection

The INTERFACE BOX is not designated for use within areas with explosive hazards.

2.1.4 Interaction with Other Devices

Interactions with other devices are not known.

2.1.5 Electromagnetic Environment and Influencing of Devices



CAUTION!

The use of other accessories, other converters and other cables than those specified by PROTEC or provided in the documentation of the component manufacturer can result in increased electromagnetic interference or reduced electromagnetic immunity of the device and lead to defective operation.



CAUTION!

The use of the INTERFACE BOX immediately next to other devices or with other devices in a stacked form should be avoided, as this could result in defective operation. If use in the manner described above is nevertheless necessary, the INTERFACE BOX and the other devices should be observed to ensure that they are working properly.



NOTE

The properties of this device, determined by emissions, allow its use in industrial areas and in hospitals (CISPR 11, class A). When used in residential areas (for which class B is usually required by CISPR 11), this device may not provide adequate protection for radio services. The user may need to take remedial measures such as relocating or realigning the device.

The INTERFACE BOX is intended for use in an environment in professional health care facilities (e.g., clinics, surgery centres, physiology practices ...)

3 Installation and Calibration

3.1 Checking the Package

Check that the package has no damages.

3.2 Checking the Scope of Delivery

Check that the system has been delivered completely.

It consists of the following components:

- INTERFACE BOX with power supply unit and USB cable.

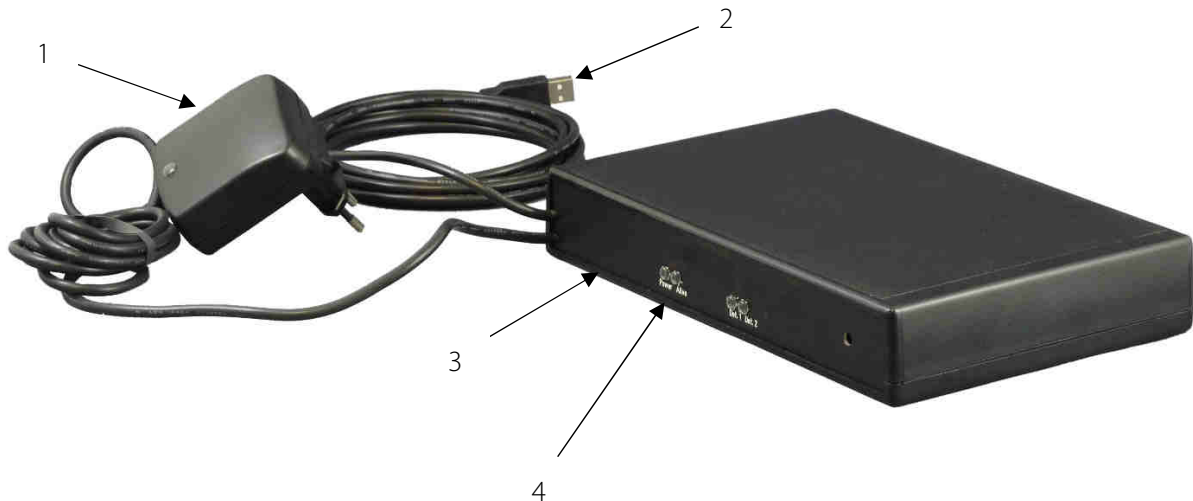

1 Plug-in power supply unit

2 USB cable

3 Housing

4 LEDs



NOTE

Do not use a cable extension.
Use only supplied cables.



CAUTION!

Pull out the mains plug before opening the housing!
If the generator is connected, disconnect the generator from the power supply and secure it against being switched on again.



CAUTION!

Never set up the INTERFACE BOX in the patient environment. The INTERFACE BOX must always be installed near the control PC. Make sure that no liquids enter the housing.

3.3 Installation

- Remove the cover of the housing.
- Insert the cables for the generator and the grid unit through the front panel (if necessary, drill additional holes).
- The connection types are described in the following figures. Figure 1 and Figure 2 are to be selected according to the generator connection. Figure 3 shows the direct connection of the hand switch to the INTERFACE BOX.
- If all cables are connected correctly, they are fixed inside the INTERFACE BOX with a cable tie.
- Close the housing and screw the top and bottom parts together with the supplied screws.
- Glue the enclosed rubber feet to the bottom of the housing that the INTERFACE BOX has a secure stand.
- Place the INTERFACE BOX in a location where it has a secure stand and cannot fall down. The INTERFACE BOX should be placed close to the work PC.

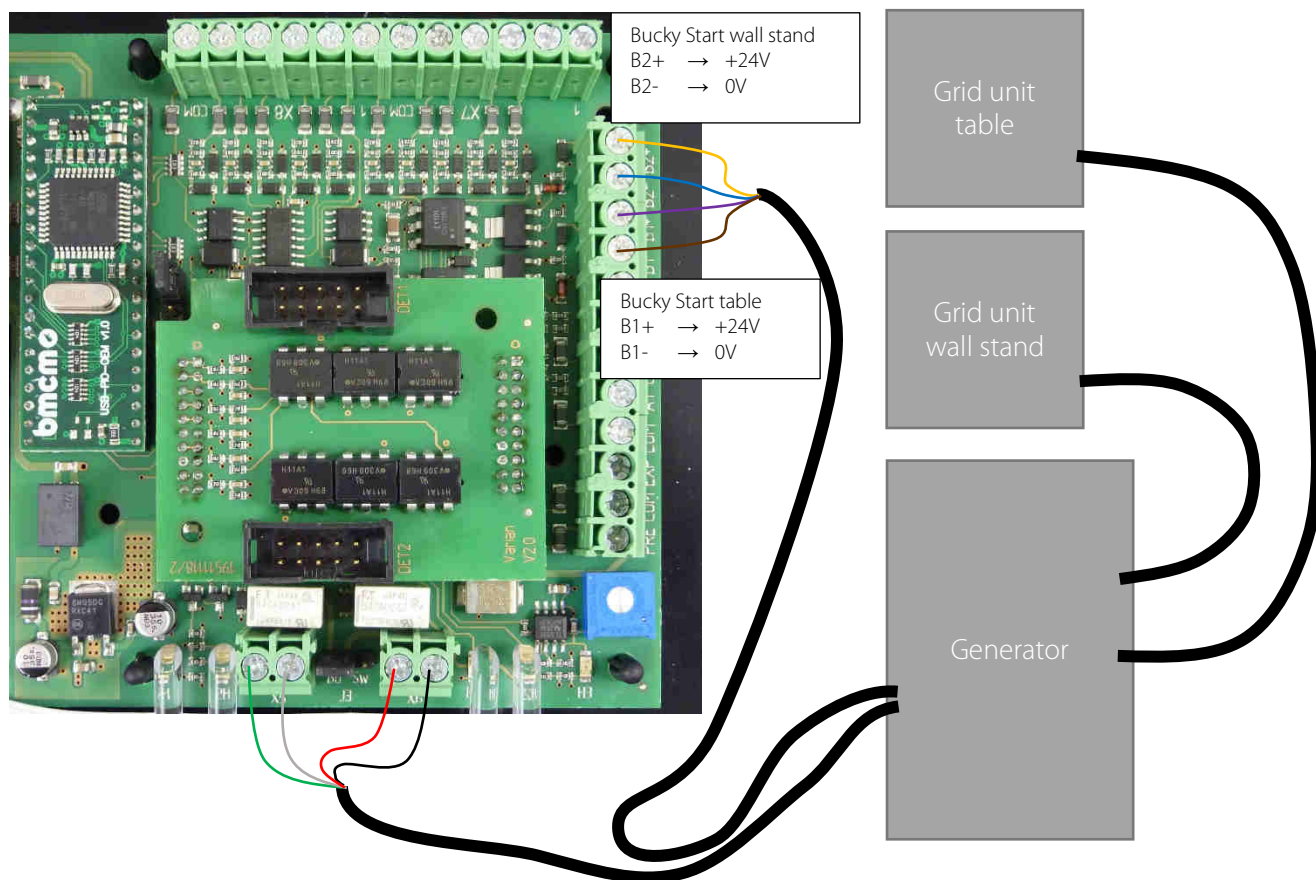

Figure 1: Generator connection (general)
(Cable colors may differ)

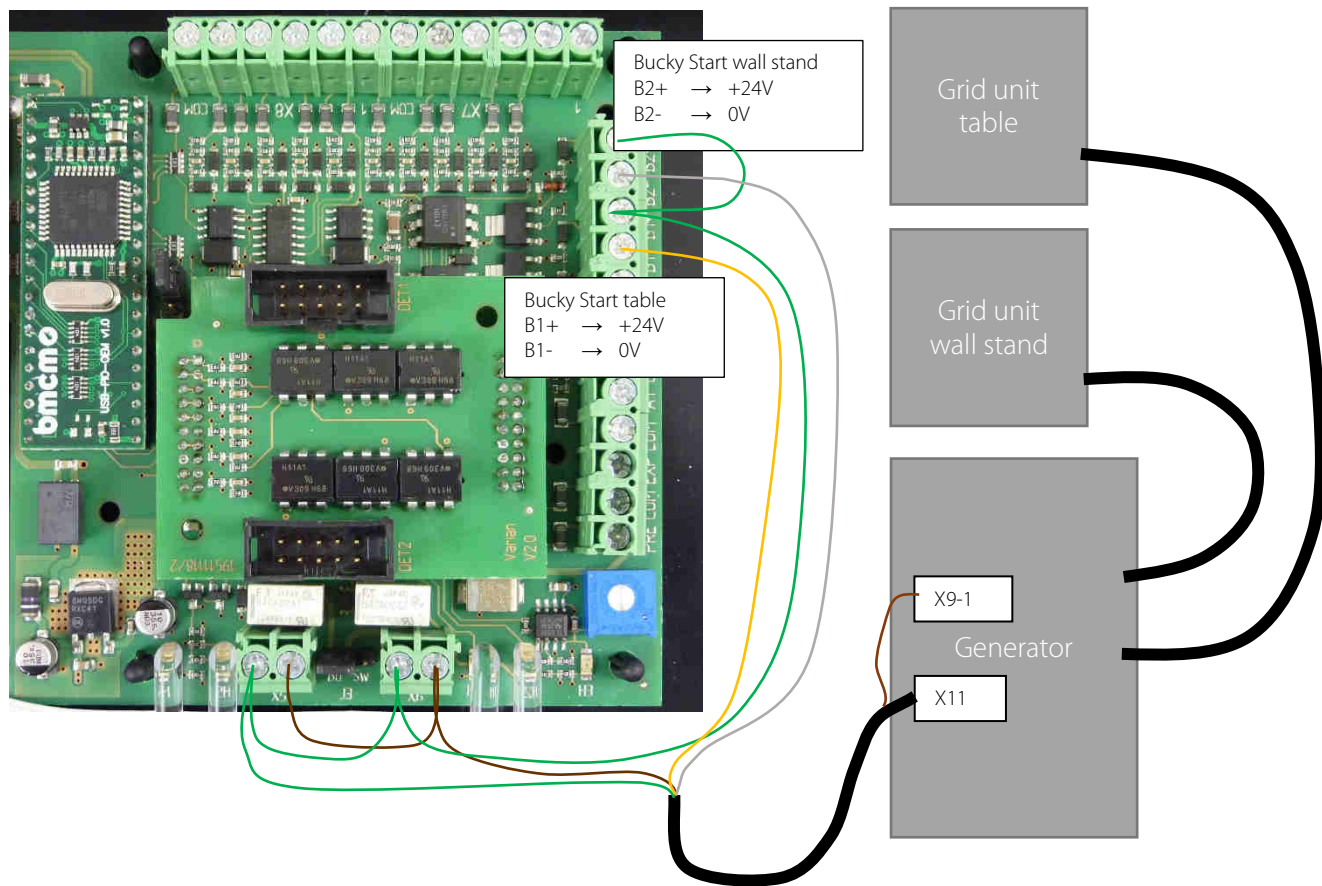

Figure 2: Connection with PROVARIO HF

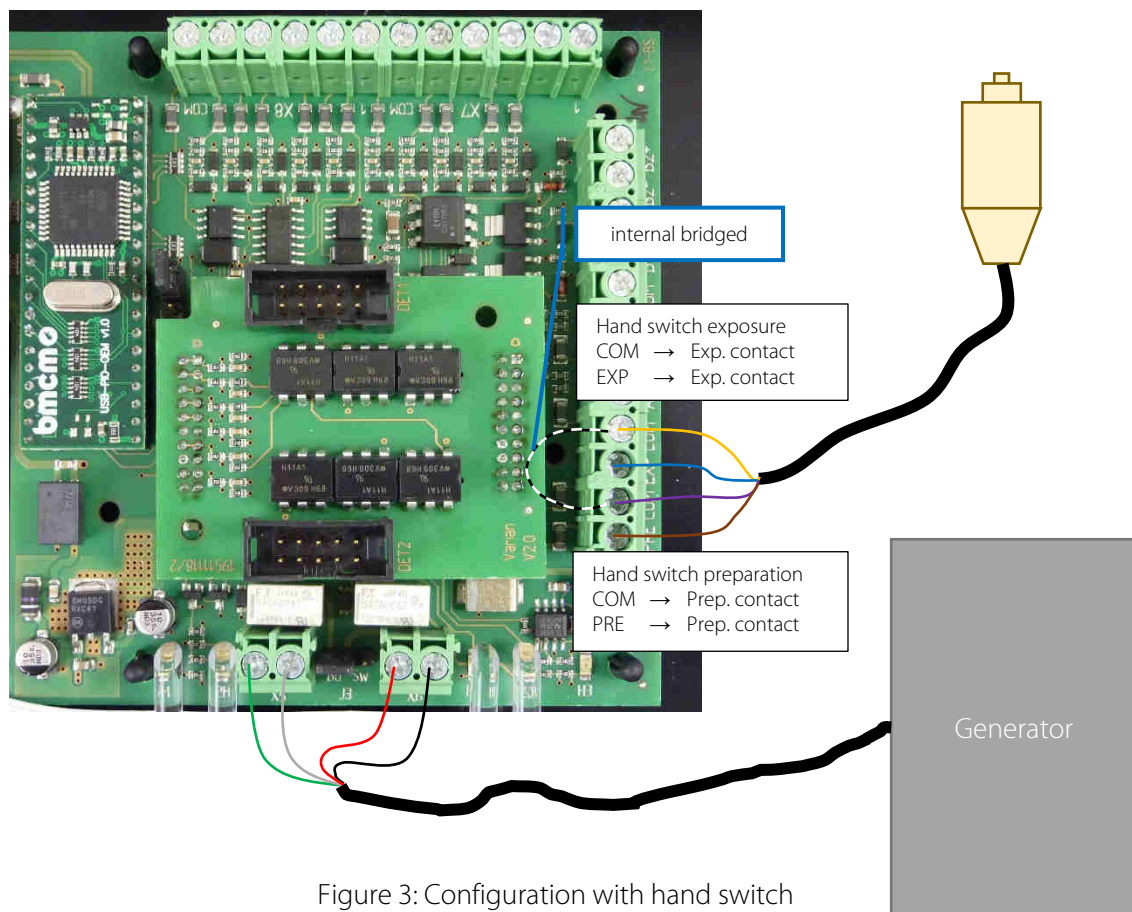

Figure 3: Configuration with hand switch
(Cable colors may differ)

3.4 Calibration

No calibration is required for the INTERFACE BOX.

4 Control Elements and Displays

4.1 Signal-LEDs of the INTERFACE BOX

Overview of the Signal-LED status display:

- Power: Indicates if the power supply is connected and working.
- Alive: Lights if the CONAXX 2 software is sending the alive signal to the INTERFACE BOX (only necessary in certain operating modes).
- Det. 1: Lights if detector 1 receives shot release from the software or if preparation (prep) is pressed during installation with hand switch.
- Det. 2: Lights, if detector 2 receives shot release from the software or if exposure request (exp) is requested during installation with hand switch (press hand switch down).



5 Handling

5.1 Operation of the INTERFACE BOX

The INTERFACE BOX cannot be operated directly by the user. The functionality is completely controlled by the CONAXX 2 software.

The INTERFACE BOX does not have a power on button. When the power supply unit is plugged in, the INTERFACE BOX is ready for operation.



CAUTION!

Make sure that the power supply unit is securely seated in the socket and cannot accidentally fall out.

6 Safety and Maintenance



WARNING!

Caution, risk of electric shock!

Before cleaning or disinfecting, unplug the power supply unit of the INTERFACE BOX from the power outlet. This disconnects the INTERFACE BOX from the power source and avoids the risk of electric shock.

6.1 Introduction

In this chapter you will find information about safety and maintenance that are necessary to ensure the correct and reliable function of the device after installation.

6.2 Reusability

The INTERFACE BOX must no longer be used with patients if it shows signs of wear (e.g., metal abrasion, wear of insulations) or dangerous technical defects (e.g., bent parts) or if the resulting image quality (e.g., artifacts in the image) is insufficient.

In this case, please contact PROTEC service department or a service company authorized by them immediately.

6.3 Cleaning and Disinfection



NOTE

Caution!
Possible material changes!



WARNING!

Make sure that no liquid enters the interior of the housing during cleaning and disinfection in order to prevent electrical short circuits and/or corrosion.

6.3.1 Cleaning

The cleaning of the INTERFACE BOX is very easy due to the very good quality surface coating. This is usually only done with a dry cloth.

Do not use corrosive, dissolving or abrasive cleaning agents, which could damage the device surfaces or the coating.

Clean the device surfaces and painted parts with a damp cloth and a mild to slightly alkaline cleaning solution (e.g. RBS® Neutral T) and wipe dry.

Chrome parts may only be wiped with a dry woollen cloth.

6.3.2 Disinfection

The disinfection must be performed in accordance with the current applicable legal requirements and guidelines corresponding for disinfection and explosion protection.

All mechanical parts of the INTERFACE BOX, including accessories, may only be cleaned with a wipe disinfection with suitable surface disinfectants (e.g., Melsept® SF, 15 min. application time at 2% concentration). The information provided by the disinfectant manufacturer on concentrations and application times must be observed.

**WARNING!**

No highly flammable disinfectants may be used! For safety reasons, spray disinfection must not be carried out, as the spray mist could enter the device and cause short circuits or corrosion.

If disinfectants are used that can form explosive gas mixtures, the device may only be switched on again when the gas mixtures have evaporated!

6.4 Inspection and Maintenance

**WARNING!**

No maintenance or repair work may be performed while the INTERFACE BOX is being used with a patient!

All maintenance and repair work may only be performed by personnel trained or authorized by PROTEC.

6.4.1 Daily Monitoring before and during the Examination Operation

Make sure that the "Power"-LED lights up green. Only if it lights up, the INTERFACE BOX is correctly supplied with voltage. During the shot, either only "Det. 1" or "Det. 1" and "Det. 2" must light up green together, depending on the connection of the X-ray system.

6.4.2 Safety-related Checks

No safety-related checks are required for the INTERFACE BOX.

6.4.3 Maintenance

No regular maintenance is required for the INTERFACE BOX.

6.4.4 Warranty**NOTE**

You will find the current warranty conditions in your order documents or in the price list valid at the time of purchase.

Repairs and spare parts in the event of improper use are also excluded.

Warranty work may only be carried out by trained specialists.

6.4.5 Product Service Life

The INTERFACE BOX is designed for a service life of 10 years when used in accordance with the specifications and regular maintenance by PROTEC service department or a service company authorized by them. After the product has reached the end of its service life, further use is at your own risk.

6.4.6 Disposal Notes

The INTERFACE BOX contains various plastics and heavy metal. When disposing exchange and spare parts, or if necessary, the entire device, the valid rules and regulations must be observed. Please contact your contractual partner or service company or commission a company specialized in disposing the respective components.

7 Power Supply



NOTE

The INTERFACE BOX is powered by a wide range power supply and must always be connected to an external wall outlet.

The specifications of the power supply are:

Input voltage:	100 to 240V
Frequency:	50 to 60Hz
Power:	205 to 110mA



WARNING!

To avoid the risk of an electric shock, this device may only be connected to a supply network with a protective earth conductor.

7.1 Electromagnetic Compatibility (EMC) according to EN 60601-1-2



CAUTION!

As a medical electrical device, the INTERFACE BOX is subject to special precautionary measures regarding EMC and must be installed and commissioned in accordance with the EMC information contained in the accompanying documents.



CAUTION!

Portable RF communication devices (radio devices) should not be used closer than 30 cm (12 in) to the marked parts and cables of the INTERFACE BOX. Failure to observe can lead to a reduction in the performance characteristics of the device.

7.1.1 Guidelines and Manufacturer's Declaration – Electromagnetic interference

The INTERFACE BOX is intended for use in the electromagnetic environment specified below. The customer or the Operator of the radiographic system should assure that it is used in such an environment.

Measurement interference	Compliance	Electromagnetic Environment
RF emissions CISPR 11	Group 1	The X-ray component uses RF energy exclusively for its internal function. As a result, its RF emissions are very low and it is unlikely that nearby electronic devices will be influenced.
RF emissions CISPR 11	Class A	The device is suitable for use in facilities other than residential areas and those that are directly connected to the public supply network, which also supplies buildings that are used for residential purposes, provided the following warning is observed:
Harmonic emissions EN 61000-3-2	Class A	
Voltage fluctuations/ flicker emissions EN 61000-3-3	compliant	Warning: This device is intended for use by medical professionals only. This is a class A device according to CISPR 11. This device can cause radio interference in residential areas, in which case it must be necessary to take appropriate remedial measures such as new

		alignment, rearrangement or shielding of the device or filtering of the connection to the location.
--	--	---

Immunity Test	EN 60601-1-2 Test Level	Compliance Level	Electromagnetic Environment - Guidance
Electrostatic discharge (ESD) EN 61000-4-2	± 8 kV contact discharge ± 2 kV, ± 4 kV, ± 8 kV, ± 15 kV air discharge	± 8 kV contact discharge ± 2 kV, ± 4 kV, ± 8 kV, ± 15 kV air discharge	Floors should be made of wood, concrete or ceramic tiles. If the floor is covered with synthetic material, the relative humidity must be at least 30%.
Fast transient electrical disturbance variables / burst EN 61000-4-4	± 2 kV for power supply lines ± 1 kV for input/output lines	± 2 kV for power supply lines ± 1 kV for input/output lines	The quality of the supply voltage should correspond to that of a typical business or hospital environment.
Surges EN 61000-4-5	± 0,5 kV ± 1 kV ± 2 kV	± 0,5 kV ± 1 kV ± 2 kV	The quality of the supply voltage should be that of a typical commercial or hospital environment.
Magnetic field at the supply frequency (50/60 Hz) EN 61000-4-8	30 A/m 50/60 Hz	30 A/m 50/60 Hz	Magnetic fields at the mains frequency should correspond to the typical values found in a business and hospital environment.
Voltage dips, short interruptions and fluctuations in the supply voltage EN 61000-4-11	<5 % UT (>95 % dip in UT) for ½ cycle <5 % UT (>95 % dip in UT) for 1 cycle 70 % UT (30 % dip in UT) for 25/30 cycles <5 % UT (>95 % dip in UT) for 5/6s	<5 % UT (>95 % dip in UT) for ½ cycle <5 % UT (>95 % dip in UT) for 1 cycle 70 % UT (30 % dip in UT) for 25/30 cycles <5 % UT (>95 % dip in UT) for 5/6s	The quality of the supply voltage should correspond to that of a typical business or hospital environment. If the user of the device demands continued operation even if there are interruptions in the energy supply, it is recommended that the device be fed from an uninterruptible power supply or battery.
Conducted disturbances induced by RF fields EN 61000-4-6	3 V/m 1 kHz 80% AM 150 kHz bis 80 MHz	3 V/m	
Radiated RF disturbances EN 61000-4-3	3 V/m 1kHz 80% AM 80 MHz to 2.7 GHz	3 V/m	See table below

NOTE: These guidelines may not apply in all situations. Electromagnetic propagation is affected by absorption and reflection from structure, objects and people.

Test Frequency	Frequency Band	Service in MHz	Modulation	Immunity Testing Level
----------------	----------------	----------------	------------	------------------------

in MHz	in MHz			in V/m
385	380 - 390	TETRA 400	Pulse modulation: 18 Hz	27
450	430 – 470	GMRS 460, FRS 480	FM ±5 kHz Deviation 1 kHz Sine	28
710 745 780	704 – 787	LTE Band 13, 17	Pulse modulation: 217 Hz	9
810 870 930	800 – 960	GSM 800/900, TETRA 800, iDEN 820, CDMA 850, LTE Band 5	Pulse modulation: 18 Hz	28
1720 1845 1970	1700 - 1990	GSM 1800, CDMA 1900, GSM 1900, DECT, LTE Band 1, 3, 4, 25, UMTS	Pulse modulation: 217 Hz	28
2450	2400 – 2570	Bluetooth, WLAN, 802.11 b/g/n, RFID 2450, LTE Band 7	Pulse modulation: 217 Hz	28
5240 5500 5785	5100 - 5800	WLAN, 802.11 a/n	Pulse modulation: 217 Hz	9

8 Technical Data

8.1 Dimensions

L x W x H ca. 23 cm x 15 cm x 3,8 cm

8.2 Total Weight

Housing with power supply unit ca. 0.7 kg

8.2.1 Protection Type and Protection Class

The INTERFACE BOX corresponds to protection class 2 and contains no applied parts type B (according to EN 60601-1).

8.2.2 Health Hazards

The housing of the INTERFACE BOX complies with following standards:
RoHS-compliant

8.3 Environmental Conditions

8.3.1 Environmental Conditions during Operation















Ambient temperature	+ 10°C to + 40°C
Relative humidity	30% to 75% (non-condensing)
Atmospheric pressure	700 hPa to 1060 hPa



8.3.2 Environmental Conditions for Shipping and Storage

Ambient Temperature	- 10°C to + 70°C
Relative humidity	10% to 95% (non-condensing)
Atmospheric pressure	500 hPa to 1060 hPa

9 Description of Symbols, Labels and Abbreviations

9.1 Symbols

	Atmospheric pressure limit
	Temperature limit
	Humidity limit
	Keep dry
	Fragile, handle with care
	This way up
	Attention, observe accompanying documents
	Refer to Instructions for use
	CE-marking
	Manufacturer
	Medical Device
	Order reference
	Serial number
	Unique Device Identification
	Production date

 www.protect-med.com/download	<p>This symbol indicates the need to observe the instructions for use. This is provided in an electronic format (eIFU) on our website.</p>
	<p>Disposal instructions; WEEE (Waste of Electrical and Electronic Equipment)</p>



9.2 Type Labels

MD

REF 4499-9-5001



SN SNxxxxxx



 2025-07-09



www.protect-med.com/download

 +40°C  1060 hPa  75 %

 +10°C  700 hPa  35 %

INTERFACE BOX

POWER RATING

24	V 
10	W





PROTEC X-ray Systems GmbH
In den Dorfriesen 14
71720 Oberstenfeld
Germany

UDI 

(01)04260502642429
(11)250709
(21)SNxxxxxx

TL4499-9-5001V05



INTERFACE BOX 4499-9-5001

MD

REF 4499-9-8001



SN SNxxxxxx



 2025-07-09



www.protect-med.com/download

 +40°C  1060 hPa  75 %

 +10°C  700 hPa  35 %

INTERFACE BOX

POWER RATING

24	V 
10	W





PROTEC X-ray Systems GmbH
In den Dorfriesen 14
71720 Oberstenfeld
Germany

UDI 

(01)04260502642467
(11)250709
(21)SNxxxxxx

TL4499-9-8001V05

INTERFACE BOX – SIEMENS 4499-9-8001

9.3 Positions of the Signs and Labels

Type label is attached on the underside.



9.4 Abbreviations

cm	Centimetres
kg	Kilogram
°C	Degree - Celsius
hPa	Hectopascal
DIN	German Industry Standard
EN	European Standard
CE	CE-marking
Hz	Hertz
mA	Milliampere
SN	Serial number